

MODERN WIRELESS



May.

1/-

Vol. II. No. 8.

Edited by JOHN SCOTT-TAGGART, F.Inst.P., A.M.I.E.E.

May, 1924.

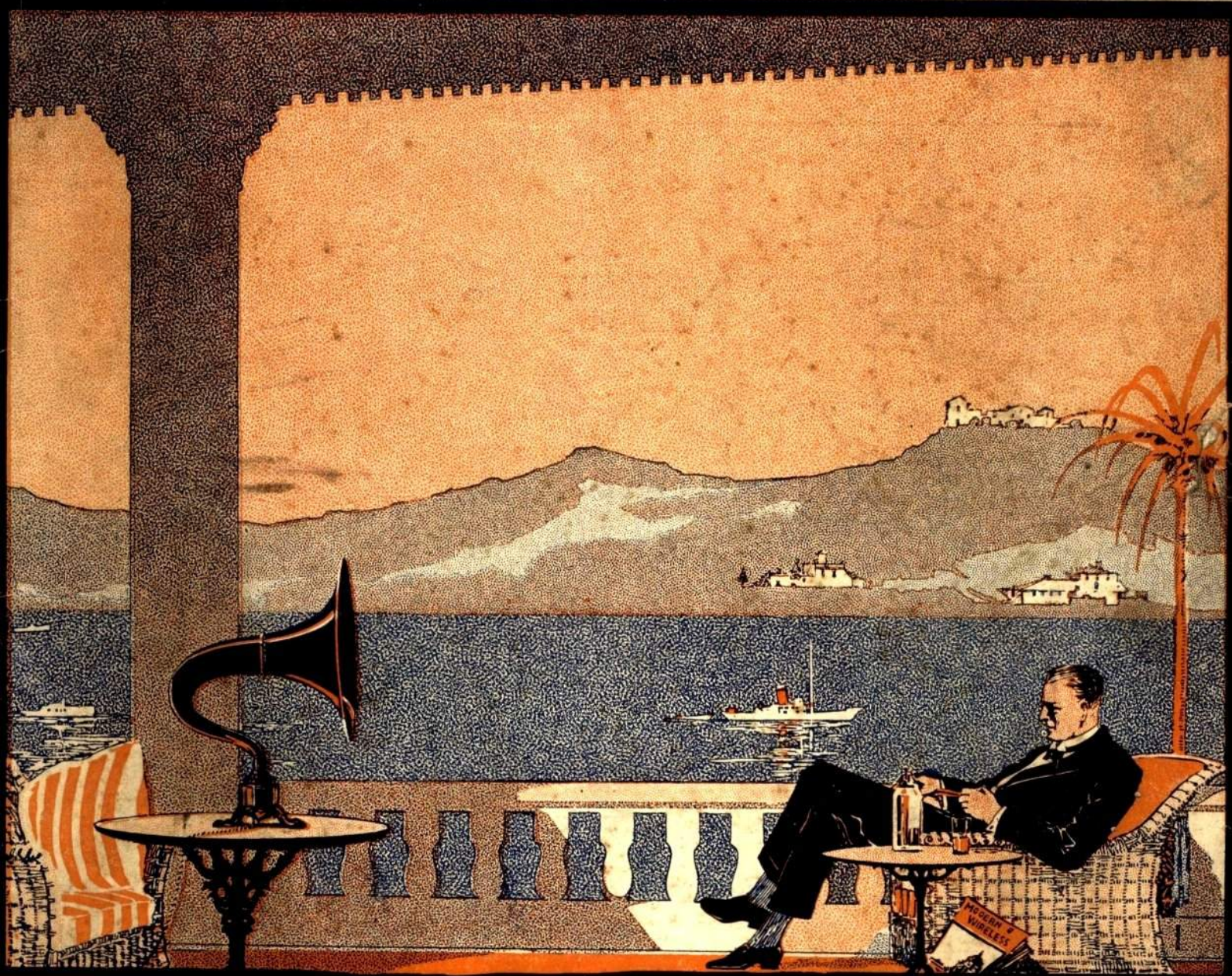

Vol. II.

No. 8

HOW TO BUILD A POWERFUL PORTABLE SET.
THE VALVE AS DETECTOR. By John Scott-Taggart, F.Inst.P., A.M.I.E.E.
A THREE-VALVE DISTORTIONLESS RECEIVER. By Percy W. Harris.
PROBLEMS OF LOW-FREQUENCY AMPLIFICATION. By R. W. Hallows, M.A.
LOUD SPEAKER ENVIRONMENT. By G. P. Kendall, B.Sc.
WIRELESS IN SCHOOLS. By E. H. Chapman, M.A., D.Sc.
A DOUBLE PURPOSE RECEIVER. By Herbert K. Simpson.

Trouble Corner: Building a Simple Crystal Set.—How to Listen to Distant Stations

Safety First



Before soldering a single connection make certain your Circuit is correct.

MANY a man has built up a Receiving Set, inserted the Valves, coupled up the batteries and hoped for the best!

Perhaps at the worst the result of his efforts has only been complete silence, but if he has been really unlucky, and his wiring inextricably mixed there has been a blue flash indicating the premature decease of his valves.

And almost invariably the cause of the whole trouble is inability to read a Circuit diagram.

Now Radio Press, Ltd., have published an entirely new Book, "Pictorial Wireless

Circuits," which makes use of a different principle to that usually employed. Instead of conventional signs every Circuit is shown with illustrations of the actual components connected together. It gives, in effect, a bird's-eye view of the finished Set.

Naturally such a method makes wiring up extremely simple and as a very wide range of Circuits is shown, ranging from simple Crystal Circuits to multi-valve Circuits, it is a Book which should be in the hands of every Wireless enthusiast. Obtainable from all Booksellers or direct from publishers (postage 2d. extra).

Every Circuit is individually described and its advantages explained. Full details of all variable components, such as condensers, resistances, grid leaks are given, so that the home constructor can build up a Receiving Set from the information furnished.

R. P. Series
No. 8.



Radio Press, Ltd., Devereux Court, Strand, W.C.2.

Pictorial Wireless Circuits

By Oswald J. Rankin.



Contents

	PAGE		PAGE
Frontispiece. A Set for the Open Air	676	Wireless in the Schools ...	709
A Powerful Portable Broadcast Receiver	677	By E. H. CHAPMAN, M.A., D.Sc.	
The Old Folks' Receiver	682	The "M.W." Single-Valve Dual Unit	711
A Radio Station for Norwegian Fishermen	683	Feeding Back the Low-Frequency Currents in Reflex Receivers	717
By DR. ALFRED GRADENWITZ.		A Two-Valve Double Purpose Receiver	722
In Passing	685	By HERBERT K. SIMPSON.	
Loud-Speaker Environment	687	Some Problems of Low-Frequency Amplification	733
By G. P. KENDALL, B.Sc.		By R. W. HALLOWS, M.A.	
A Note on the Resistance Capacity Amplifier	695	Single Valve Long - Distance Reception	742
By PERCY W. HARRIS.		Readers' Experiences with the "M.W." Modifications of the Grebe C.R.13	745
Regular Programmes from British and Continental Broadcasting Stations	698	Reclaiming Ebonite Panels	747
The Valve as an Efficient Detector	697	Reflex Wireless Receivers in Theory and Practice	751
By JOHN SCOTT-TAGGART, F.Inst.P., A.M.I.E.E.		By JOHN SCOTT-TAGGART, F.Inst.P., A.M.I.E.E.	
A "Cage" Variometer Crystal Set	702	Working and Finishing Ebonite Panels	758
By E. H. CHAPMAN, M.A., D.Sc.		Salvage by Wireless	757
A Cheap Variable Condenser	704	By LT.-COL. HAROLD F. TOWLER.	
Above and Below the Broadcast Wavelengths	705	Tested by Ourselves	761
Those Distant Stations: How to Listen for Them	708	An Australian Wireless Exhibition	765
By PERCY W. HARRIS.		Readers' Results	768

Editor:
JOHN SCOTT-TAGGART,
 F.Inst.P.

Joint Assistant Editors:
PERCY W. HARRIS.
E. REDPATH.

Staff Editors:
E. H. CHAPMAN,
 M.A., D.Sc.
A. D. COWPER, M.Sc.
G. P. KENDALL, B.Sc.
A. L. M. DOUGLAS.
R. W. HALLOWS, M.A.
S. G. RATTEE.

Scientific Adviser:
Prof. G. W. O. HOWE,
 D.Sc., M.I.E.E.

Advisory Editors:
Prof. R. WHIDDINGTON,
 M.A., D.Sc.
Prof. C. L. FORTESCUE,
 M.A., M.I.E.E.
Tel.—Central 3763.

Advertisement Managers:
SCHIEFF PUBLICITY
ORGANISATION, LTD.
 125, Pall Mall, London,
 S.W. 1.
Tel.—Regent 2440.

MODERN WIRELESS

Radio Press Ltd
 PUBLISHERS OF WIRELESS WEEKLY
DEVEREUX COURT.
 • STRAND.W.C.2 •
Tel.—Central 3763.

All correspondence relating to contributions is to be addressed to the Editor of "Modern Wireless."

Nothing contained herein is to be regarded as permission or encouragement to infringe any patent rights.

A Set for the Open Air

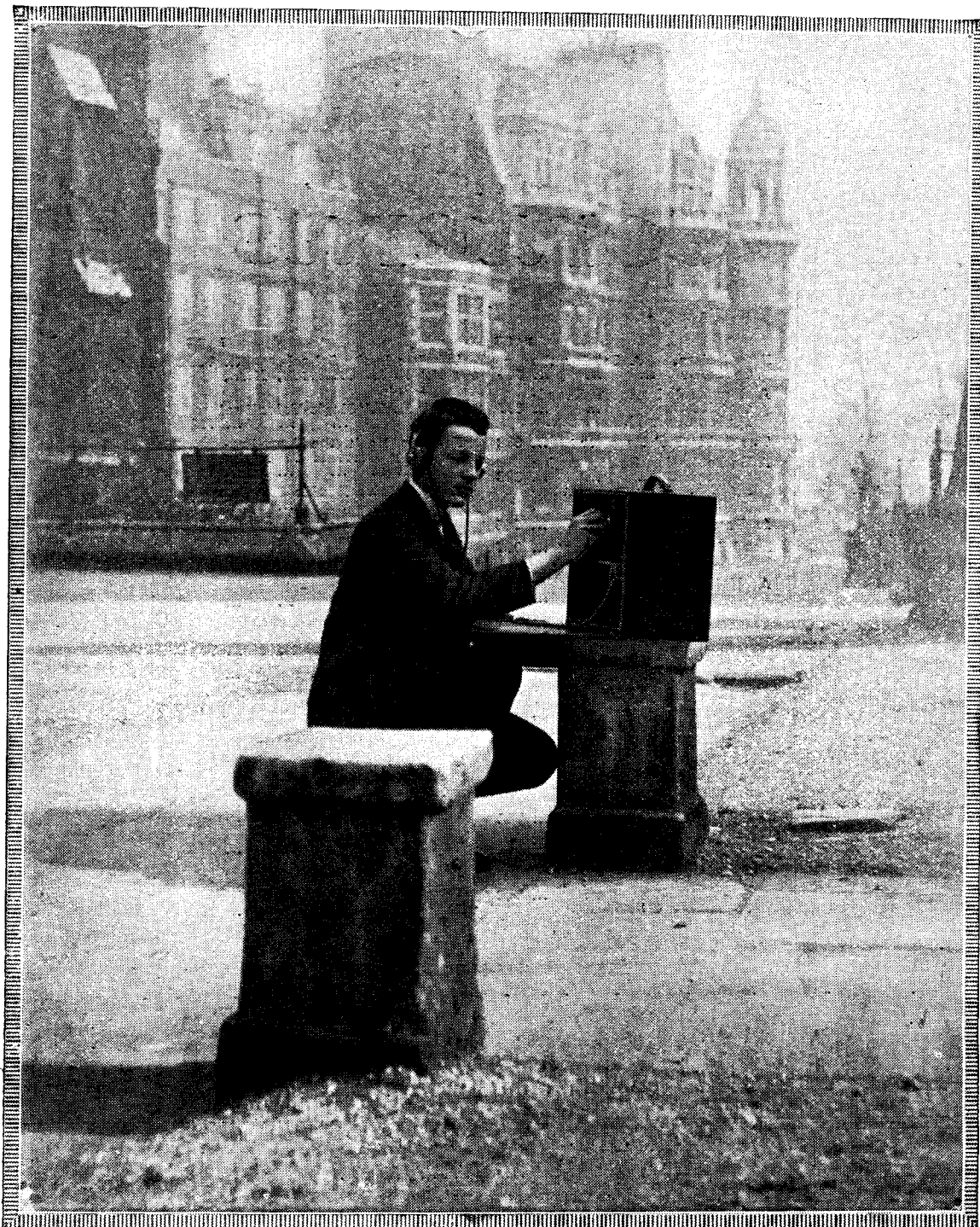

This photograph shows how the portable set described in this issue can be brought into use without a moment's delay. Within a few miles of a broadcasting station no aerial or earth are necessary.

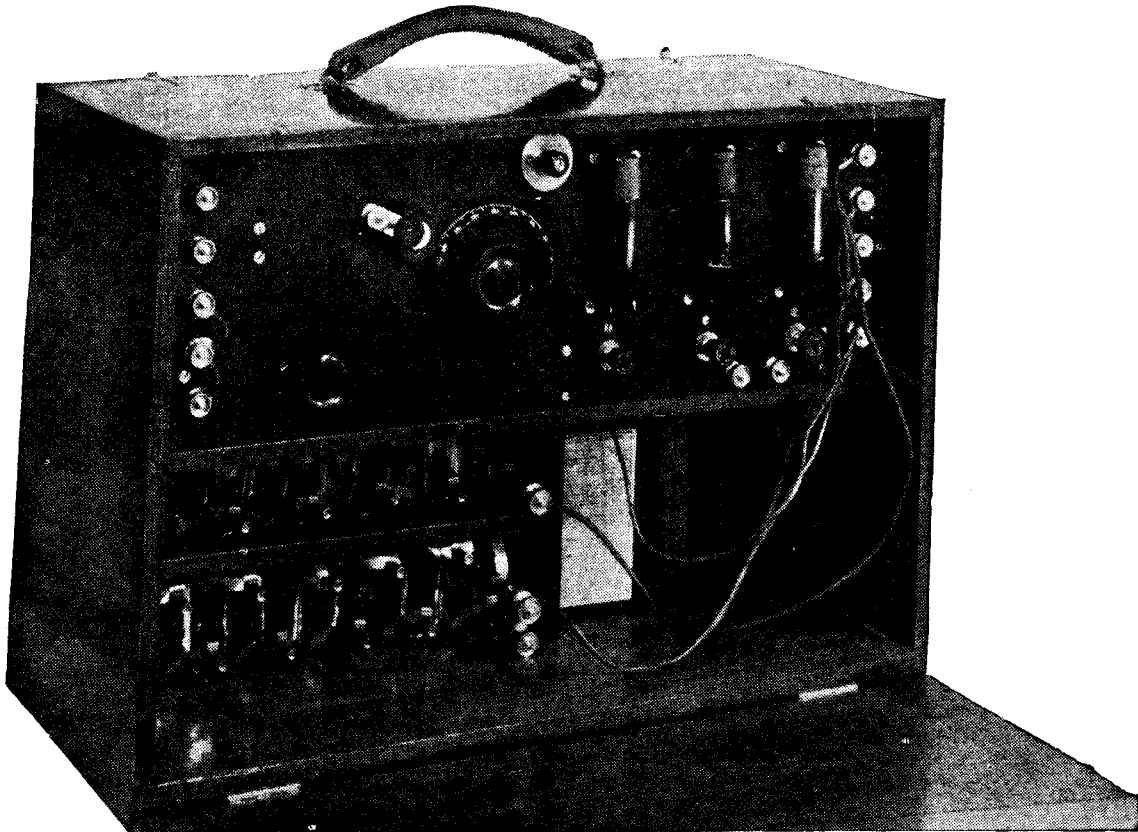

Fig. 1.—When the door is opened the controls and batteries are seen in convenient positions.

A Powerful Portable Broadcast Receiver

By HERBERT K. SIMPSON.

With the approach of the outdoor season, a portable set is required. The present article deals with a compact and efficient receiver of this type.

WHEN the evenings begin to grow lighter and the call of summer is heard, the devotee of radio begins to feel that he would like to participate in outdoor joys, while at the same time he regrets having to leave his hobby behind. There is no need, however, to neglect the out-of-doors season, or to forgo the pleasures of broadcasting.

The present set has been designed to fill the need for a powerful set, which, while being compact, inasmuch as the high and low tension batteries are included in the box, is still of neat appearance. The appearance of the finished set is seen in the photograph, Fig. 1, which shows the front of the panel, upon which the component parts are mounted. The box, as will be noticed, is divided in half, length-

wise. The top half contains the instrument, while both batteries are located below the shelf. A leather handle for carrying the set is fitted to the top of the box.

Fig. 2 is a photograph of the back of the set, with the door open. By means of this door it is possible to inspect the back of the panel, without removing the latter from the cabinet.

The Circuit

The circuit diagram of the receiver is seen in Fig. 4. It will be seen that the first valve acts

as a detector, with reaction while the second and third valves are note magnifiers.

Constant aerial tuning may be employed by connecting the aerial lead to terminal 1, the earth to terminal 5, and joining 3 to 4 and 4 to 5, terminal 2 being left free. Other arrangements of aerial circuit are possible, and a table of the various connections is given below.

Aerial Circuit Connections

A frame aerial may be used, by connecting the ends of the frame across terminals 3 and 4, 4 being

		AERIAL CIRCUIT CONNECTIONS.		
Circuit.		Aerial.	Earth.	Other Connections.
Const. Aerial	Tuning Parallel			
Condenser	1	5	3 to 4—4 to 5
Series Condenser	4	5	3 to 5
Parallel Condenser	No C.A.T. ..	2	5	3 to 4—4 to 5

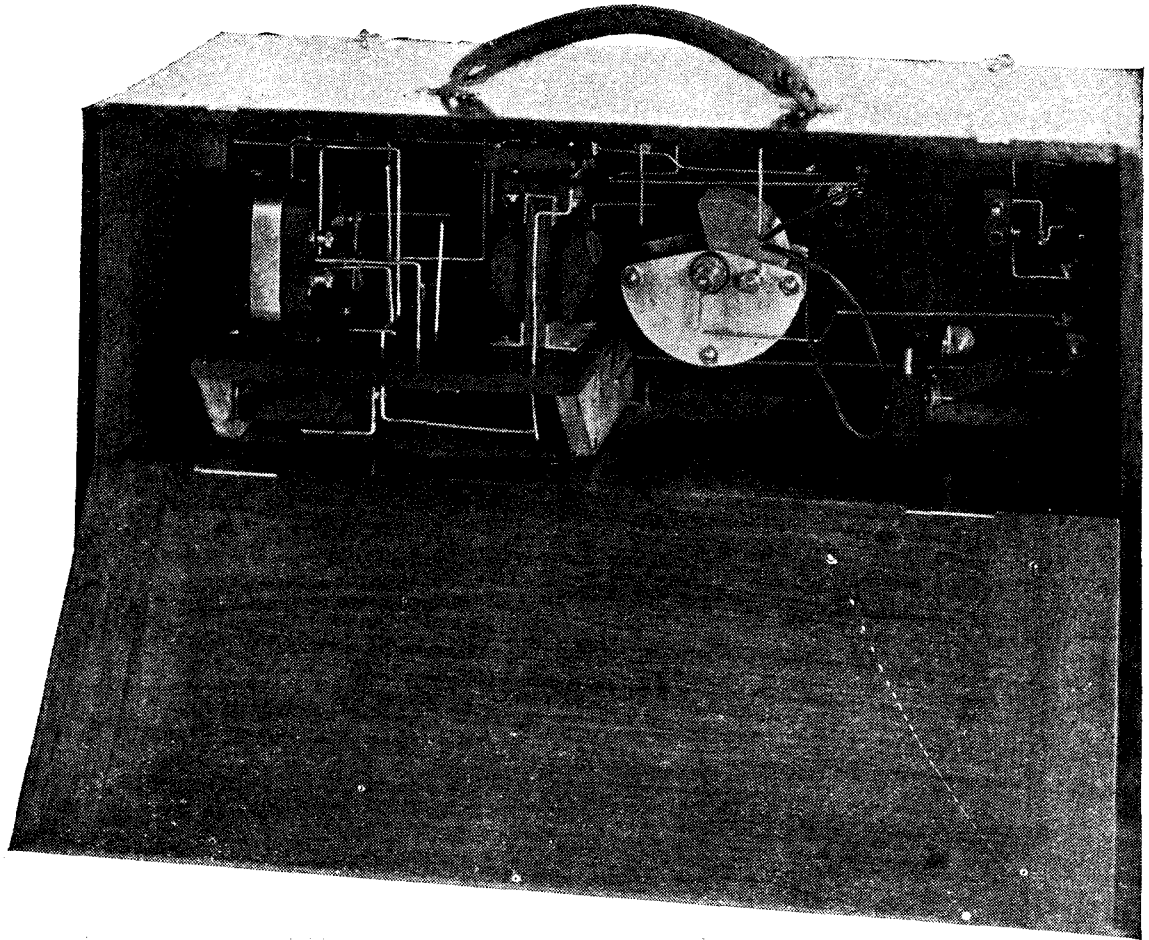

Fig. 2.—The back of the panel is easily accessible by lowering the back of the box.

joined to 5. This leaves the aerial tuning coil in series with the windings of the frame aerial, the aerial tuning condenser being in parallel with them. If it is desired to use the frame aerial alone, connect the ends of the frame across terminals 2 and 4, leaving 1 and 3 free, and join 4 to 5. The aerial coil is now removed from its socket, and the aerial condenser is in parallel with the windings of the frame. It will be seen that a condenser is shunted across the windings of the second low frequency transformer—that is, the anode of the first low frequency amplifying valve is connected via this condenser, of 0.001 μ F capacity, to the grid of the last valve. Purer reproduction is obtained in this case by using the condenser, but it is not expected that improvement will in all cases result from such an arrangement, as much depends upon the types of transformer used.

Components

The list of components and their prices includes, in this case, every-

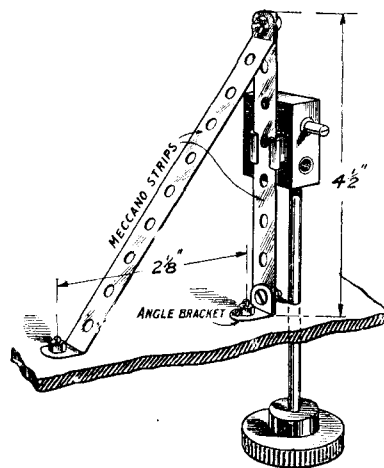

Fig. 3.—Showing how the coil holder is constructed.

thing necessary to complete the receiver, excepting aerial and loud-speaker. The aerial, in the case

of a portable receiver, may consist of a length of wire slung between two convenient trees, and if covered wire, such as the "Electron Wire," which is advertised in this journal, is used, the need for insulators is obviated, although better results will, of course, be obtained when insulators are employed. The earth connection can easily be made by knocking an iron rod, about 12 in. long, into the ground, and connecting a wire on to this.

Myers valves of the dull emitter type are incorporated in this set, their small size making them eminently suitable for this type of receiver. They are secured close to the panel, and so are not so liable to become damaged as the ordinary four pin type of valve. The constructor may, if he desires, replace them by V24 valves, or their dull emitter counterparts, the DEV.

Dull emitter valves should be regarded as a *sine qua non* in a

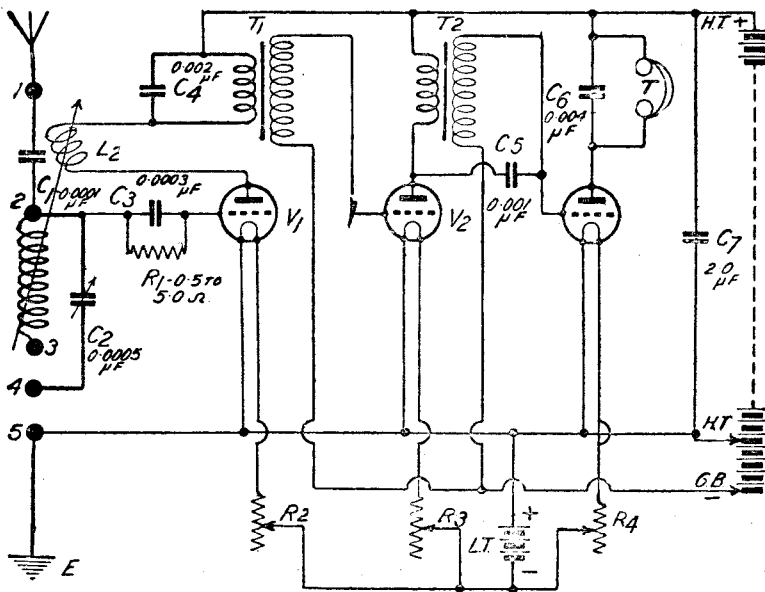

Fig. 4.—The circuit arrangement.

portable receiver, owing to the larger size of accumulator necessary with bright emitter valves.

The Exide accumulators, type

DTG, used in this set, are most suitable for this receiver, their overall size being 5½ in. high by 2¾ in. square. Two of these cells

are connected in series, and fit firmly into the space allotted to them.

The high tension battery consists of twenty-four flashlamp cells, connected in series, twelve being housed in each section of the left-hand lower half of the cabinet. Connection is made between the cells by means of a link, sold by the Small Metal Goods Co., which incorporates a socket by means of which tappings to the cells are possible. Wander plugs make contact to the battery, and flexible rubber covered leads connect to the terminals on the top panel.

The Ebonite Panels

The front panel measures 17¾ in. by 6 in., and has the valves, filament resistances, tuning condenser, and so on mounted upon it. A smaller panel is secured to the back of this main panel by means of two wooden shelves, these being secured to the front panel by two wood screws in each. This subsidiary panel carries the two low frequency transformers, while on the under-

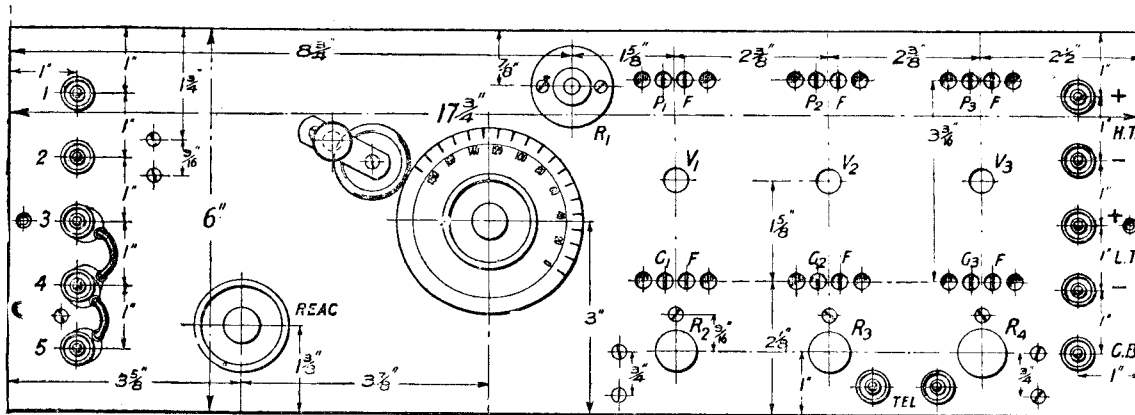

Fig. 5.—A dimensioned drawing of the front of the panel, showing how the parts are mounted.

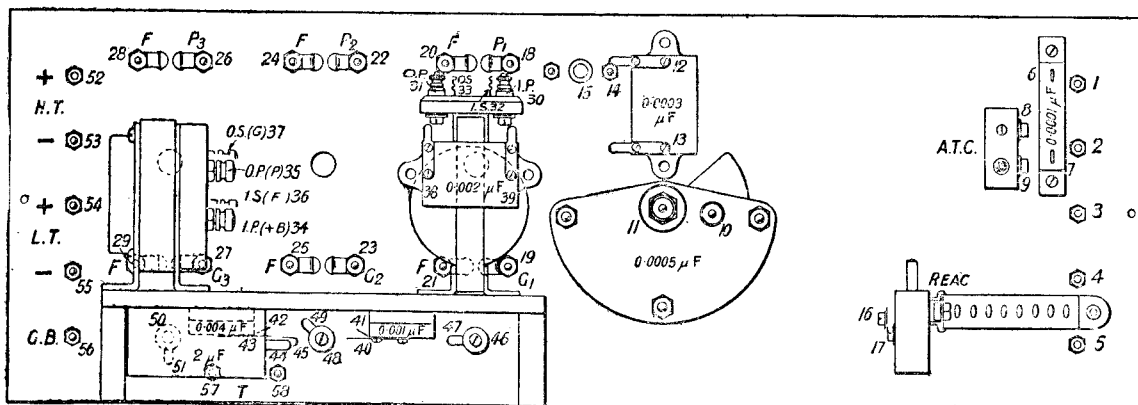

Fig. 6.—The back of the panel, with the parts numbered. The wires are omitted for the sake of clearness.

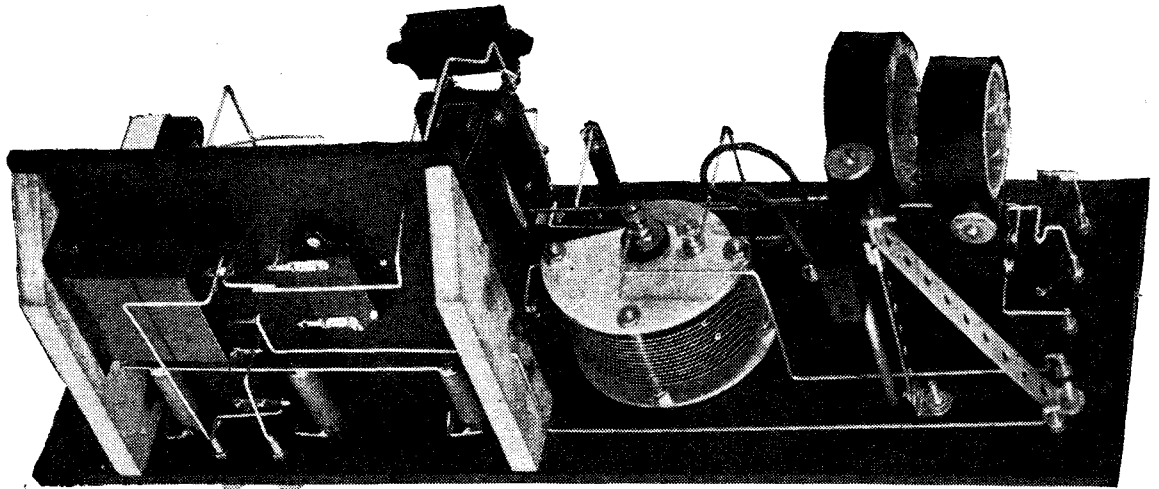

Fig. 7.—A photograph of the back of the panel, showing clearly how the smaller panel is secured to the main panel

side are located three of the fixed condensers.

A dimensioned drawing of the main panel is given in Fig. 5, and the screws which hold the wooden ledges are clearly seen. The glossy surface should be removed from the ebonite before work is commenced by rubbing with fine emery-cloth, after which the holes may be drilled to the sizes required by the various components. Many constructors will prefer to use component parts which they may already possess, and care must be taken that the holes drilled are the correct size for these. For this reason no drilling diagram of the small panel is given, as the holes necessary will vary with the makes of transformer used. Two of the Dubilier condensers are secured by screws to the underside of this panel, and the large reservoir con-

denser of 2 μ F capacity is screwed to one of the wooden ledges.

The Coil Holder

The coil holder is of exceedingly simple design, being, in fact, made from two coil plugs, two 5½ in. "Meccano" strips, one brass rod threaded at the ends, and one ebonite knob.

The construction is best followed by glancing at the drawing of the coil holder, Fig. 3. It will be seen that one of the "Meccano" strips is secured by a "Meccano" "angle bracket" to a screw passing through the panel. The other strip acts as a support for the first one, upon which the coil plug carrying the reaction coil slides.

Wiring Up

Wiring is carried out with No. 16 S.W.G. tinned-copper wire, and

should present no difficulty, the parts having been so arranged as to reduce wiring to a minimum.

It is felt that the simplest method of wiring up is to follow some sort of order, and in consequence a numbered list of points to be joined is given, and the key to the numbers is found below.

List of Numbers Allotted to Components

- Aerial circuit terminals, 1 to 5.
- 0.0001 μ F const. aerial condenser, 6, 7.
- Aerial tuning coil, 8, 9.
- Aerial tuning condenser, 10, 11.
- 0.0003 μ F grid condenser, 12, 13.
- Grid leak, 14, 15.
- Reaction coil, 16, 17.
- First valve, P., 18; G., 19; Filaments, 20, 21.
- Second valve, P., 22; G., 23; Filaments, 24, 25.

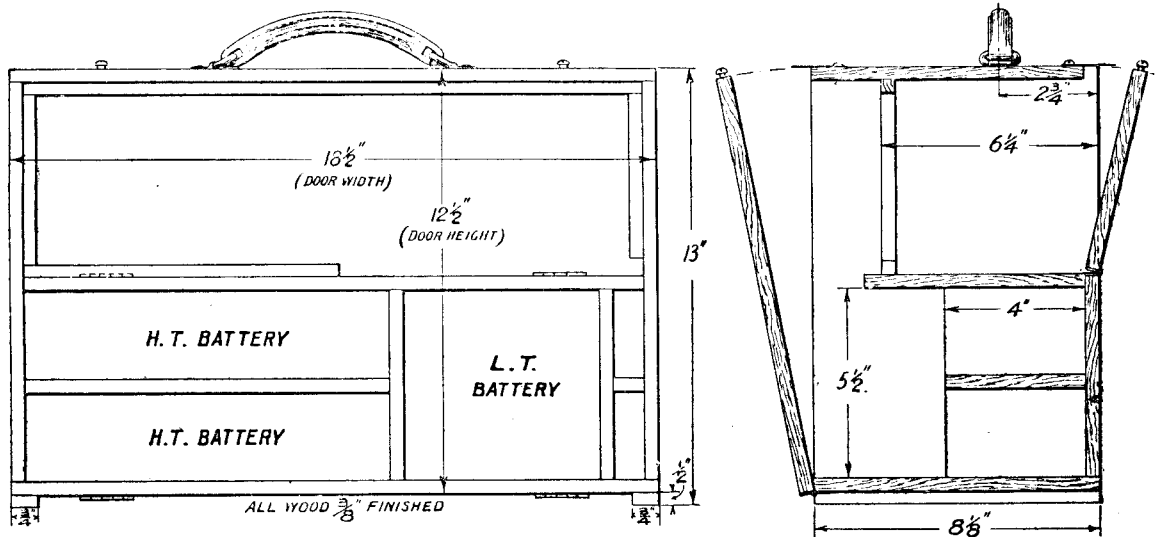

Fig. 8.—The containing box. Full dimensions are given, except in the case of the ledges for batteries, which will vary with the types of batteries used.

Components.	£	s.	d.
Cabinet (Wright & Palmer)	1	12	6
2 Panels: 17 $\frac{3}{4}$ in. x 6 in. x $\frac{1}{4}$ in... ..	4	6	
7 in. x 5 in. x $\frac{1}{4}$ in... ..	1	6	
2 Coil Plugs (Goswell Eng. Co., Ltd.) ..	2	0	
1 .0005 Variable Condenser (K. Raymond, New Type)	5	11	
1 "Fynetune" (Sparks' Radio Supplies) ..	2	6	
3 Lissenstat Minor Filament Rheostats ..	10	6	
1 Powquip Transformer (Unshrouded) ..	16	6	
1 Royal Transformer	1	0	0
1 Watmel Grid Leak	2	6	
Dubilier Condensers:			
One 0.0001 μ F	2	6	
One 0.0003 μ F	2	6	
One 0.001 μ F	3	0	
One 0.002 μ F	3	0	
One 0.004 μ F	3	0	
1 T.C.C. 2 μ F Condenser (Leslie Dixon & Co.) ..	5	6	
12 Terminals	1	6	
3 Myers Dull Emitter Valves, at 21s. each ...	3	3	0
24 Flashlamp Batteries, at 6d. each	12	0	
24 Links (Small Metal Goods Co.)	3	0	
2 Exide Dull Emitter Accumulators, Type D.T.G.	10	0	
Acid and Charge	3	0	
Screws, Wire, Leads, etc... .. .	2	0	
1 Handle for Cabinet	2	9	
Total	£10	15	2

The Cabinet

Having completed the panel, we may turn our attention to the containing box, a dimensioned drawing of which is seen in Fig. 8. The construction of this article is quite straightforward, and the man of average wood-working ability should experience no difficulty in turning out a well-made box. The work is carried out in $\frac{3}{8}$ in. finished mahogany, and the overall dimensions are 18 $\frac{1}{2}$ in. long by 12 $\frac{7}{8}$ in. high by 8 $\frac{3}{8}$ in. deep, the depth being measured from front to rear. The large shelf is fixed at a depth of 6 in. from the top, so that the panel fits evenly into the upper compartment. The vertical divisions in the lower compartment help to support the main shelf, and the left-hand compartment is made of such a size that the high tension battery fits tightly into the space. This compartment is divided into two by a horizontal shelf, and one half of the battery rests on top of the shelf, while the other half is located below.

The accumulators fit into the right-hand lower compartment, and pieces of wood should be fixed to the inside of the cabinet in order that the batteries may be firmly held in position.

The cabinet used was obtained from Messrs. Wright & Palmer, of Forest Gate, from whom replicas could be obtained at short notice.

The whole of the front of the cabinet is hinged at the bottom, while only the upper half of the back is movable.

The panel is secured in the cabinet by means of wood screws passing through the panel into the ledges shown in Fig. 8. The

Third valve, P., 26; G., 27; Filaments, 28, 29.
 First L.F. transformer, I.P., 30; O.P., 31; I.S., 32; O.S., 33.
 Second L.F. transformer, I.P., 34; O.P., 35; I.S., 36; O.S., 37.
 Bypass condenser C₄, first transformer, 38, 39.
 Bypass condenser C₅, second transformer, 40, 41.
 Telephone condenser C₆, 42, 43.
 H.T. reservoir condenser C₇, 44, 45.
 Filament resistances, R₂, 46, 47; R₃, 48, 49; R₄, 50, 51.
 H.T. +, 52; H.T. -, 53; L.T. +, 54; L.T. -, 55; G.B. -, 56.

Telephones, 57, 58.
 (1-5) (2-7-8-14-12) (14-10) (3-9)
 (4-11) (5-45-54-53-28-24-20).
 (15-13-19) (16-31-38) (17-18)
 (21-47) (22-35-40) (23-33).
 (25-49) (26-42-58) (27-37-41)
 (29-51) (30-39-44-34-52).
 (44-57-43) (32-36-56) (46-48-50-55).
 A photograph of the back of the panel is given in Fig. 7, and another view will be seen in Fig. 8. No difficulty should be experienced in following out the course of the wires when this photograph is used in conjunction with the wiring diagram, Fig. 6.

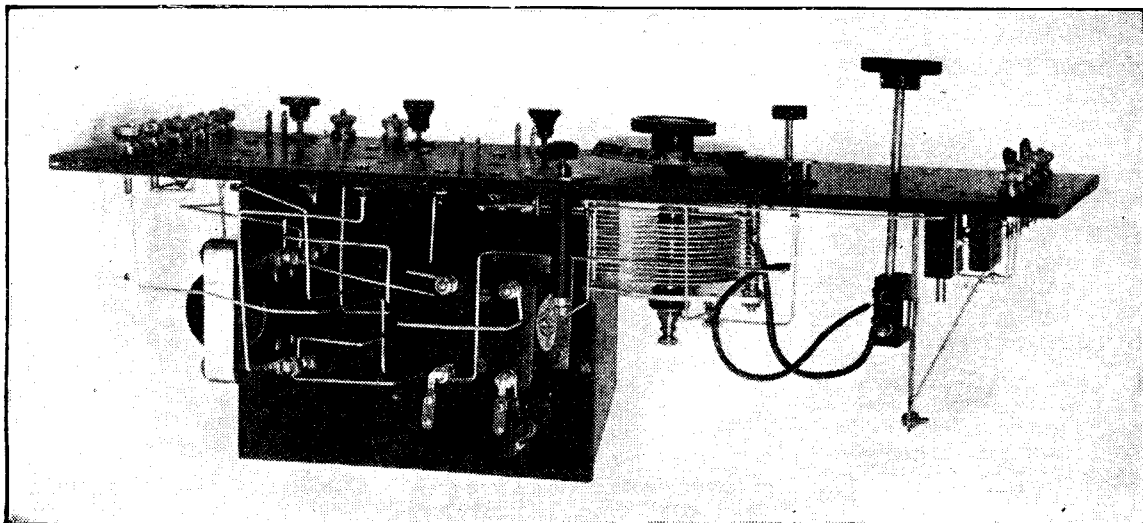

Fig. 9.—Edgewise view of the panel, revealing simplicity of layout.

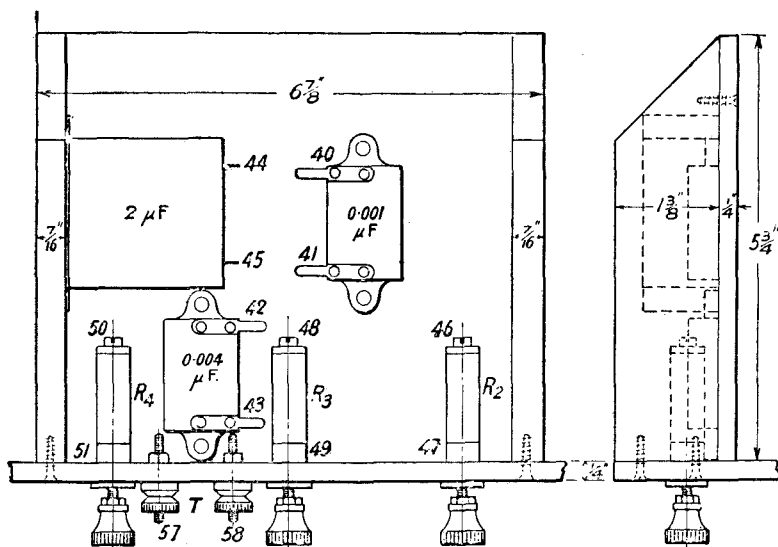

Fig. 10.—Underneath the subsidiary panel. The numbers are for wiring up; used with Fig. 6, the layout of the wiring can be planned.

ledge is cut away at the bottom right-hand side to allow the shelf and subsidiary panel to fit.

Batteries and Coils

The high tension battery should have its cells separated by means

of pieces of waxed paper, as otherwise the battery will become discharged in a very short time. Long strips of paper of the same width as the height of the batteries may be soaked in hot paraffin-wax, and when cold, wound in and out of the separate cells, which are then connected in series by means of the clips previously mentioned.

When using the constant aerial tuning system a No. 50 coil may be used in the aerial socket, while the reaction coil may be a No. 50 or No. 75. If the constant aerial tuning system is not used the aerial coil may be either No. 35 or No. 50, according to the size of the aerial used, while with a series aerial condenser the longer wave B.B.C. stations may be tuned in with a No. 75 coil in the aerial circuit.

Grid bias is obtained from the high tension battery by means of a wander plug in the same manner as the high tension supply.

Operation of the Set

Using the constant aerial tuning system with the coils mentioned above the local station should be easily tuned in by moving the variable condenser over its scale, keeping the reaction knob in the position of loose coupling—that is, pulled right out. When the signals are picked up the coils may be brought slightly closer together to increase the strength, but not sufficiently near to cause the set to oscillate.

The set will be found to give very good results on quite a short aerial, while more distant stations should be received with a reasonably good aerial system.



Fig. 11.—The set is easily carried in its own case.

Blue Prints.

For the convenience of readers, full-size blue prints of the panel and wiring have been prepared, and are obtainable from the offices of Radio Press, Ltd., price 1s. 6d. each, post free. The numbers are—the front of the panel, No. 33A; and the back of the panel, showing the wiring, No. 33B.



To the Editor of MODERN WIRELESS.

SIR,—I can imagine that I am only one of a great number of persons who followed the instructions you gave in the MODERN WIRELESS of October last for the construction of "The Old Folks' Receiver," and I did not write before as I thought you might have more correspondence than you would have time to attend to. However, as I have now been "receiving" for four months, through the "Old Folks," I feel that the least I can do is to write and thank you for the immense pleasure I have had throughout the winter months, and this pleasure has been shared by the members of my family and many parishioners. It is an immense and unqualified success. I use a Baby Sterling. I followed your instructions *absolutely* and I do not see how the apparatus can be improved upon. We are five miles from the Newcastle Broadcasting Station, which is, of course, a great advantage.

It is really "a joy for ever," and I think it a thing of beauty as well. You expressed a wish that any who made the apparatus would write and tell you what results they had got. I may say that I am stone deaf in one ear and the other one is not really first-class, so I found the 'phones a great nuisance, and I should have given up the "wireless craze" altogether if it had not been for your delightfully practical design and particulars. Again, many thanks, and I hope you have had many other similar expressions of appreciation.

I really hear the loud-speaker splendidly and hardly realise my deafness at all when it is at work.

Yours, etc.,
CHAS. E. LITTLE.

The Rectory, *Whickham*,
Co. Durham.

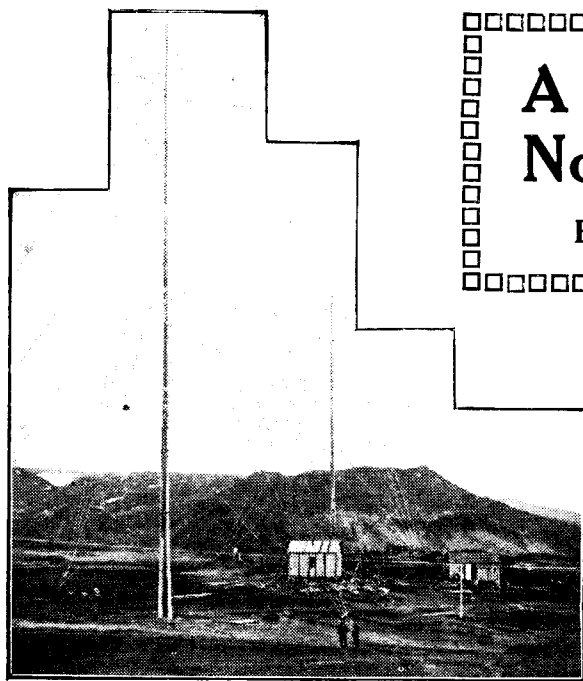

The masts and aerial at Jan Mayen.

A Radio Station for Norwegian Fishermen

By Dr. ALFRED GRADENWITZ

The general interest in broadcasting has rather tended to divert attention from the importance of wireless to navigators and fishermen. In this article our contributor describes a very important station on a tiny island in the polar circle.

ON account of the frequency of sudden storms on the coasts of Norway, the lives and property of many thousands of fishermen there depend mainly on the reliability and prompt spreading of weather reports. Numerous meteorological stations installed by the Government all over the country, especially along its coasts, therefore ensure an excellent weather service. Still, the north western coast had so far been relatively unprotected. The weather station on Iceland, truth to tell, could be relied upon to signal any storms coming from the south, while those approaching from the north were taken care of by the Spitzbergen station. However, there was a wide gap between these two stations through which storms coming from north west were often allowed to overtake without warning the fisher-folk on the high sea.

Thanks to the energetic work of engineer Ekerold and the financial co-operation of the State and private parties, it has now been possible to resort to the services of radio-telegraphy with a view to keeping a good watch also on this last gate of invasion, so that, according to recent returns by Prof. Hesselberg, of Christiania, at least 1,400 fishermen each year can be kept from being drowned and material to the value of many millions from being destroyed.

To the north of the polar circle,

a small island about 31 miles long and 2-9 miles wide, called Jan Mayen. Being throughout its length studded with extinct volcanoes, the highest of which reaches a height of about 8,300 ft., its barren soil, apart from a few miserable herbs and mosses, does not allow any vegetation to thrive. The fauna, however, is more plentiful and varied, polar foxes and bears, seals and a wealth of birds, such as gulls, halcyons, guillemots and tjalks, dwelling on the island.

about midway between Iceland and Spitzbergen and at about a distance of 750 miles from the Norwegian coast, there lies

The task of building a radio and meteorological station on this arctic island, of course, gave rise to many difficulties, especially in connection with the installation of the antenna masts. The western mast, 160 ft. in height, having been completed on November 6, 1921, an iron wire, 500 ft. in length, provisionally laid out on the ground, was used for receiving purposes, it being possible thus to receive all European high power stations with a Telefunken valve reaction receiver without any amplifier. When using an amplifier there were, on the other hand, heard the 1 kw. valve transmitter at Königswusterhausen, near Berlin, the stations of Spitzbergen, Iceland, Lyngby, Copenhagen, etc. The transmitter, designed on the "singing spark" system, with an antenna output of 1.5 kw., could with the

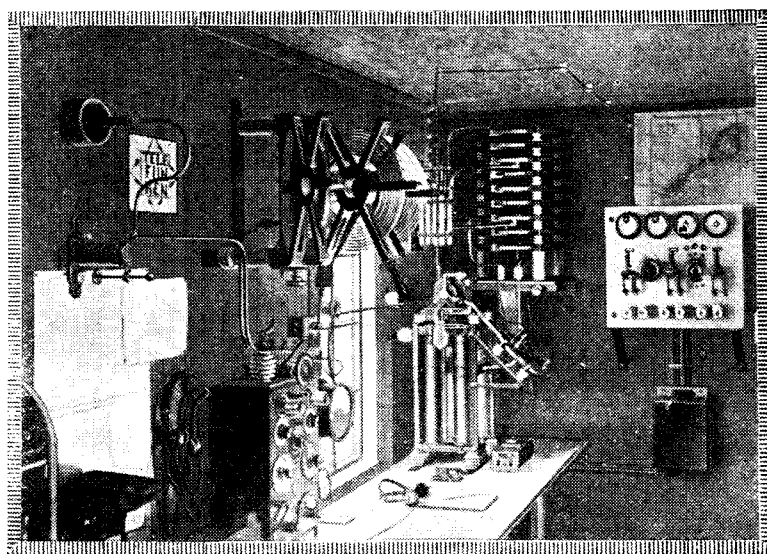

The interior of the station on Jan Mayen Island. A quenched spark transmitter is fitted.

provisional antenna arrangement communicate with Ingoy Radio near Harumerfest, Fauske and Reykjavik (Iceland), thus covering by day distances of up to 800 miles a truly remarkable performance.

Severe sand storms delayed the erection of the second mast, and, while making any outdoor work impossible, gave rise to interesting observations. In fact, the friction of sand particles would increase the atmospheric electricity, thus charging the provisional iron wire counterpoise and interfering with receiving on low notes. In order to make the station independent of such disturbances, the ground system was enlarged by digging copper plates into the soil. Heavy atmospheric disturbances were also experienced with northern lights and hail-storms, which, however, could not interfere with a smooth radio service.

When the weather had improved at last, the second antenna mast was erected, and after completing the antenna and counterweight, the station could definitely be

tuned, the most advantageous wave (1,000 metres) showing an antenna current of 14.8 amperes.

The primary outfit of the station comprises an 8-h.p. paraffin oil engine and 6-kw. shunt generator, installed together with an alternate converter in an engine-house about 65 feet away from the station building. Inasmuch as no cooling or drinking water is available in the neighbourhood, this had to be provided by thawing the snow. On November 14, 1922, the new station could take up its main task, a regular weather service. On November 17 the Telefunken men left the Island, leaving Mr. Ekerold in the company of three gentlemen in charge of the station, in order, on that lonely island, cut off from the outside world, to devote themselves to their humanitarian task. During those months which have elapsed since the opening of the station, it has been working without any hitch, sending out its weather reports three times a day to the radio station of Fauske near Bodö,

Norway, whence they are taken charge of and broadcast. These reports, yielding information on the extent and intensity of cyclones, have been found to afford all desirable safety against sudden storms.

Jan Mayen Station is of the highest importance not only for storm warning, but for the normal weather service as well. In conjunction with Spitzbergen, Iceland and vessels passing on the Atlantic, it gives a good idea of atmospheric conditions in those parts, enabling the development of the weather often to be predicted for several days in advance and thus guarding against disagreeable surprises.

It has been suggested now to erect a similar radio and meteorological station on the island of Shannon, situated to the north of Jan Mayen, and, accordingly, even nearer to Greenland, as well as to provide a broadcasting service on the lines of the German economic service, receiving stations being installed at about 500 harbour places along the coast of Norway.

A Portable Transmitter and Receiver

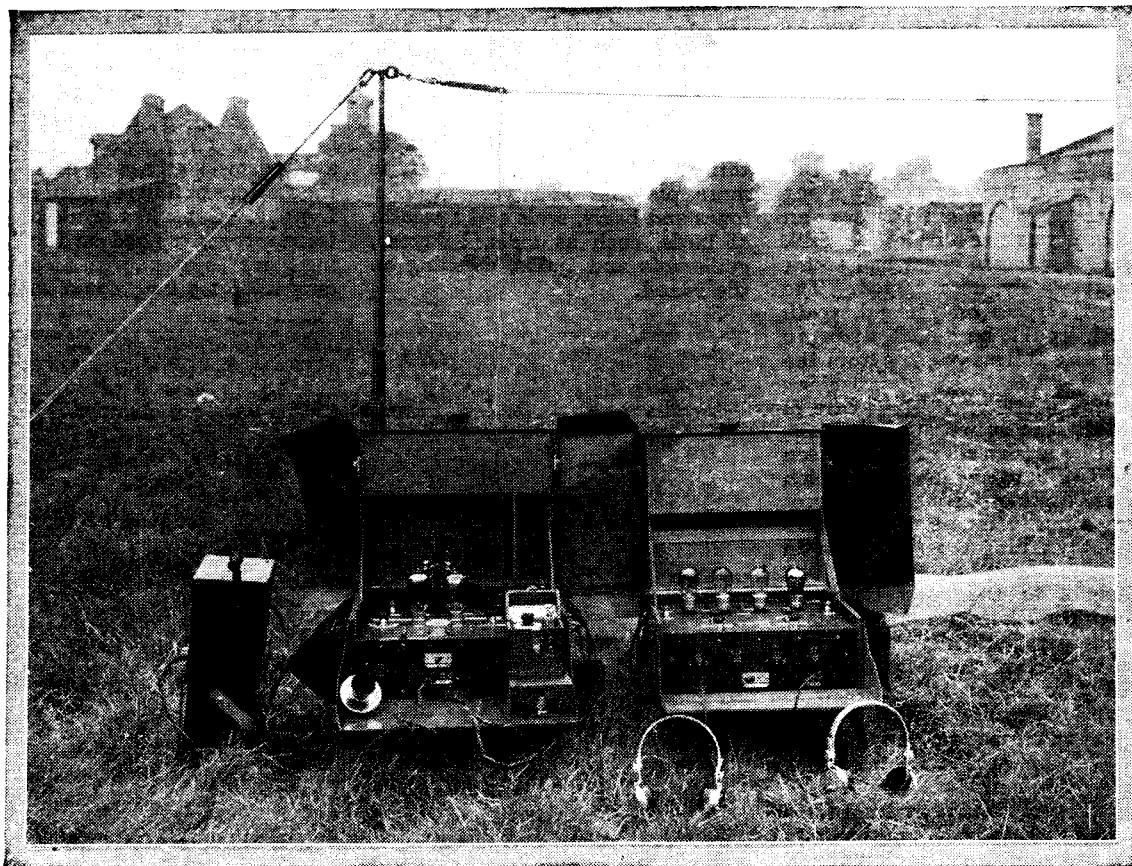

A complete portable telephony transmitting and receiving station, manufactured by Marconi's Wireless Telegraph Co., Ltd., and exhibited at the British Empire Exhibition.



Unpropheticable

AT the risk of incurring your displeasure by the perpetration of a pun I cannot help remarking at the outset of this paragraph that few things are more unprofitable than to become a prophet. If things turn out as you said they would, your friends merely look upon you with scorn when you mention the fact, remarking "Oh, any ass could have foreseen that." If, on the other hand, your best predictions go astray, the same kind of critics will not hesitate to rub the thing well and truly in on every possible occasion. It is therefore with a certain amount of diffidence that one ventures to assume the prophetic mantle and to look ahead even for the shortest period. Be that as it may, I am going to rush in where angels fear to tread and to tell you that whatever may have happened in the past, this summer, at any rate, is going to see no slackening off in the nation's enthusiasm for wireless. Last year we had our first wireless summer, and people did to some extent forsake their receiving sets for the tennis court, the croquet lawn, or the punt. After all, it is not surprising, for one must have open air in the glad summer-time, and nobody, however keen a wireless man he might be, wanted to lug round with him an accumulator weighing 40 lb. at the beginning of the journey and at least 400 lb. by the time he came to the end. Thirty-foot masts too, even if they are of the jointed variety, are not easily carried on the running boards of the car, the carrier of the motor-bike, or in the attaché-case. It was not, then, surprising that most of us left our

wireless sets at home, promising ourselves to return to them with renewed enthusiasm as soon as the longer days drew on.

But this year all is different. In place of the heavy, and at times very wet, accumulator you have the light and tight dry cell, which requires no Hercules to carry it even when the thermometer is registering some appalling reading in the shade—has it ever struck you how extremely lucky thermometers are in summer-time? They spend their entire time luxuriating in the shade—the towering mast, too, is no longer an essential, nor is it necessary this year that, should you happen to have brought no mast with you, you should proceed to scale the highest convenient tree to the no small detriment of your best flannels. The frame aerial has put the lid on that, so to speak. This year you really can make a sound and efficient multi-valve set that will fit, batteries and all, into an attaché-case and that will not weigh more than a pound or two. For this reason we shall be able to take our wireless sets with us wherever we may go. We can sit calm and comfortable beneath the canopy of the sheltering trees and enjoy to the utmost the loud-speaker's rendering of a talk on how to keep cool in hot weather, our enjoyment being in no way lessened by a mental picture of the speaker working himself up into a perspiring frenzy in a stuffy studio. We can have our concerts out of doors in the evening, and if we so wish we can dance on the tennis-lawn to the strains of the Savoy bands. We shall picnic this summer to the accompaniment of wire-

less, whether the scene of our revelry is on terra firma or upon the river. But when we take our holidays, the wireless set will go with us as a matter of course, instead of being left neglected at home.

Atmospherics?

Another temporary wearer of the prophet's mantle has been rash enough to predict that we are going to have a horrid time with atmospherics this summer. He stakes his prophecy upon the fact that the sun is due to have another eruption of spots, or else that he will not have any spots at all—I forget which. But, anyhow, he seems to be rather worried about it. This dread threat leaves me cold. After all, one must have an atmospheric or two in summer, for otherwise the seasons would seem to be out of joint. And what of the wretched man who brings to a picnic party a set that won't work? Without them he would be lost. But if he has his wits about him he can retrieve the situation immediately by announcing that they are so bad that it would be dangerous to life and limb for him to attempt to work his set. But to return to genuine atmospherics, those who have had a few years' experience of wireless in summer-time in this country will agree that they are seldom bad enough to matter very much, and their effects are, of course, minimised if you use a frame instead of an outdoor "wave-snatcher." We shall have our atmospherics, of course, just as we shall have heat waves, sea serpents and giant gooseberries. America has the highest buildings, the longest bridges, the driest

drinks and the tallest stories, so she has naturally the most de-vastating brand of atmospherics.

The Language Problem

For the same reason they have chosen to regard all electrical disturbances that affect wireless folk under the name of static. This word is merely one instance of how the American language differs from our own and is growing daily less and less like it. Years ago I maintained that in a few generations our own speech would be like a foreign language to America's, and vice versa. You have only to read their books to see that they are developing a speech of their own which is quite different from ours. Occasionally we borrow a few words from them, and they return the compliment by pinching some of ours, but on the whole the two tongues are growing up quite apart. Here, for example, are some wireless terms in English and American :—

ENGLISH.	AMERICAN.
A wireless set A radio.
Aerial Antenna.
Earth Ground.
Terminal Binding post (a terminal in America is what we should call a terminus).
Accumulator A battery.
High-tension battery B battery.
Grid battery C battery.
Valve Tube.
Reaction coil Ticker.
Soldering iron Soldering copper.
Tuned plate Tuned impedance.
Loud-speaker Loud-talker.

There are dozens of others, as you will have discovered if you have ever dipped into the pages of an American wireless magazine. One curious little point is that they never speak of high and low frequency but always of radio and audio frequency. In their diagrams R.F.T. and A.F.T. stand for high and low frequency transformers respectively. I told you some time ago that I was endeavouring to compile a dictionary for the use of earnest students who study American works. The need for it is growing daily greater, but I feel that the task is getting beyond me.

Quite apart from the language, the Yanks and ourselves are developing wireless apparatus along rather different lines. High-frequency amplification in straight circuits is very little used, though you will find fearsome-looking wiring diagrams with as many as five note magnifiers in them. Thank heaven that I, for one, have not to listen to *that* big noise. At present they are going through a kind of epidemic of monster freak sets and wondrous new circuits which appear almost every week much more formidable-looking than their predecessors. I expect that some of the owners of these monsters will have a gay time if the prediction

concerning static really does come off this summer.

Infringing My Copyright

I am shocked to hear that a schoolboy, living, I believe, in London, has produced a set embodying a Felix, to which I established a claim in these notes some time ago. The lad, it appears, has turned out a crystal set mounted upon a cat cut out of wood, one of whose luxuriant whiskers impinges upon the crystal, the cup being held in a clutching paw. I have not yet decided under what enactment, statute or law I shall proceed against him. It is with great regret that I shall do so in any case, for one always likes to see the young idea shooting. Perhaps if I consult one of my legal friends he will find a way for me and I shall issue a Habeas Felicem or a Cave Canem or something of that kind which will do the trick. In any case, even if I win, I shall probably emerge from the proceedings without a penny to my name, but I shall have the satisfaction of knowing that I have thoroughly vindicated my right to being the sole owner of the ululator or receiving Felix as applied to wireless. I wish that I could also vindicate my right to my own Felix which disappeared suddenly in the midst of a series of most interesting experiments and has not been heard of since, despite the fact that I go to the back door every night without fail and make a noise like a saucer of warm milk.

Most Regrettable

I am awfully sorry that that beautiful word the mho did not flourish, as its originators doubtless hoped that it would. In case you do not know what a mho is, I may explain briefly that it is an ohm turned inside out. What I mean is that you measure the resistance of a piece of wire in ohms and its conductivity in mhos, a mho, as the text-books neatly put it, being the reciprocal of an ohm. Got that? Very well, then. The idea, I think, might have been carried much further. For example, why should we not measure the output of a run-down battery in flocs or the current consumption of a burnt-out valve in pmas? These are both extremely pretty and useful words. There is something Russian-looking about the first, I admit, and the second might almost be the name of a letter of the Jugo-Slavian alphabet; but they are none the worse for that. Again, we might measure the non-inductance of a coil that won't induct in cims or the capacity of a shorted

condenser in daraforcims. To go a little further, would it not save an immense amount of trouble if we could simply despatch to the proprietor of the local charging station a brief note saying simply: "Dear Sir,—Will you kindly send for my rotalumucca." There will be no need to do anything else, for he, being an intelligent man, will know that you desire him to fetch your run-down accumulator to be charged. In the same way those who take our burnt-out valves into hospital and provide them with new filaments would know at once what you meant if you wrote that you were sending them a couple of evlavs. Being always a pioneer in these matters, I have just returned to one maker a couple of elbairavedona enatsisiers. I am wondering if he will know what I mean, for the idea is not yet fully recognised. You being a person of intelligence will, of course, gather that they were anode resistances which were so variable that the process of varying them has resulted in an attack of temporary deafness from which I am just convalescent.

Defeated

The only word that really defeats me is "dud," for its reciprocal or inside-out form is precisely the same as the original, so that it is impossible to transpose the letters in order to turn it into a term of praise. This reminds me of the story, which you have possibly heard before, of the school inspector, a kindly fellow with an idea that he was ingenious, though he wasn't, who paid a visit to a north country school. With the intention of showing the class which he was taking that they were utterly unobservant he tried a little experiment. "I want you to tell me some girls' names," he said, "and I will write them up upon the black-board." The top boy suggested Mary, which went up as Yram without provoking any comment. The second boy: Ethel, which was also transposed. The inspector was delighted with the success of his experiment, for no one appeared to notice what he was doing. As the class gave name after name in turn, he was composing a beautiful little homily upon the value of observation which he meant to rub in most thoroughly. However, he had counted his chickens before they were hatched, for at the bottom of the class sat a small, dirty, unbrushed and unintelligent looking lad, who, when his turn came, smiled slowly and then said: "Hannah. Now mess that about, if you can."

THE LISTENER-IN.

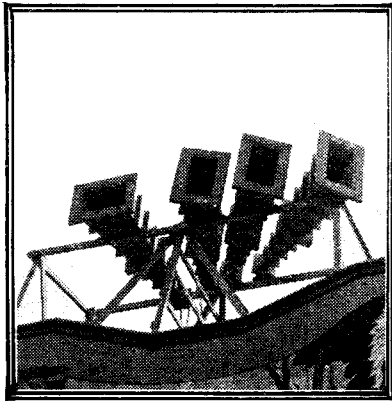

Loud-speaker horns at the British Empire Exhibition.

PROBABLY everyone who reads these lines will have noticed the very curious effects produced by talking in an empty house or an empty lecture room, the most noticeable being that if one speaks at all loudly the result is a confused echoing din which may be quite unintelligible in extreme cases. The impression is usually that unless the speaker employs quite a low tone, he is drowned by the echoes of his own words, and although this seems paradoxical, we shall see that it is precisely what occurs.

Suppose that the empty lecture room fills with people, or carpets and furniture are placed in the empty house, what do we find? The acoustic conditions at once become normal, *i.e.*, the echo effects are reduced to the amount to which we are accustomed, and we are no longer annoyed by them. This somewhat extreme example will serve to demonstrate the fact that the nature of the environment in which a sound is produced has a very considerable effect upon the way we hear that sound, and may, indeed, so modify it as to make it well-nigh unrecognisable.

The actual amount of reverberation which takes place is a most important matter in a hall designed for concerts, and a study of the same property in connection with loud-speakers is well repaid by the control over the quality of the reproduction which is thereby gained. This point does not seem to be very widely realised among users of loud-speakers, and it must be emphasised that given a really good loud-speaker worked from reasonably distortionless circuits, it is the placing of the instrument in the room and the nature of the room itself which decides whether or not the reproduction shall possess the pleasing

Loud-Speakers and Their Environment

By G. P. KENDALL, B.Sc., Staff Editor.

The actual placing of the loud-speaker in the room has often a noticeable effect upon the quality of the results, and these notes should help to give a useful knowledge of this little-understood subject.

quality of naturalness which everyone desires.

To make this apparent we must revert to the question of reverberation once more, and try to get a clearer idea of the nature of the process. We have seen that in a room with very pronounced echo effects the sound of a person speaking may become blurred and

indistinct, and this is because what is known as the "rate of decay" of sounds in that room is very slow. The sound of each syllable is *prolonged* by the reverberation to such an extent that it has not died away sufficiently to permit the next syllable to be properly heard when it is enunciated: the two mingle and a confused sound



Arranging loud-speaker horns ready for broadcasting a Good Friday service from 2LO to the congregation of Hinde Street Wesleyan Church, London.

is the result. To remedy this state of affairs, it will usually be noticed that the speaker will unconsciously begin to enunciate more deliberately in a few minutes, thus allowing time for each word or syllable to die away before it is followed by the next.

In the same room it would be found that an orchestra would sound similarly confused and marred by too much reverberation, but it must not be thought that the ideal conditions are those which would be obtained by going to the other extreme and eliminating *all* reverberation, because the result would be anything but pleasing. Reverberation can, of course, be reduced by increasing the sound-absorbing powers of the room, by draping its walls, floor and ceiling with non-reflecting material, and preferably by filling it with an audience as well. Under these conditions the music would lack continuity, and the quality of resonance to which we are accustomed would be lacking. Speech, too, would be accompanied by a sense of effort and a feeling that it was impossible to make those at the back hear, just as in out-door speaking. Conditions approaching these are considered necessary in the studios of the smaller size used for broadcasting, and it is often observed that visitors raise their voices as though in the open air.



The Sterling loud-speaker (large type).

Evidently, the ear will reject as "unnatural" anything except the approximate degree of reverberation to which it is accustomed, and what we must seek in loud-speaker reproduction is the happy mean between the two extremes which I have described. It is not often that trouble is experienced as a result of too little echo effect, but more commonly too much takes place with a badly placed loud-speaker reproducing fairly strong signals.

It is usually impossible to predict the correct position for the loud-speaker in any given room to produce just the right amount of reverberation, but it is commonly best to place the mouth of the horn facing the wall at a distance of about two feet, preferably near a corner. A very pleasing effect can often be produced, too, by putting the loud-speaker in a corner facing *outwards* with a light curtain hung across the corner perhaps a foot in front of the opening of the horn. However, experiment alone can decide whether any given arrangement is suitable for a particular room, and trial should always be made of all the possibilities. The improvement in naturalness which can be obtained in this way is often quite surprising.

A less important aspect of the question of environment relates to the question of stationary waves. They are not often produced under average conditions, but their occasional occurrence is somewhat difficult to prevent. The following experiment will probably be found interesting as a demonstration of the existence of stationary sound waves. Set the receiver into a howl by tightening the reaction (*not* on broadcast wave-lengths!) and adjust the note to a fairly high pitch. Place the loud-speaker with its horn facing the wall obliquely, and then go to the other end of the room, close one ear, and try the effect of moving the head about. It will probably be found that there are definite areas of louder and weaker sound, thus showing the presence of fairly well-defined nodes and antinodes.

The effect, when listening with both ears, is a sense of discomfort, since the sound heard by one ear may be much louder than that of the other. With speech the trouble is not usually noticeable, but with certain musical notes it may be quite objectionable. The remedies to try are principally concerned with the position of the loud-speaker, since although one may not be able to eliminate one set of stationary waves, it may

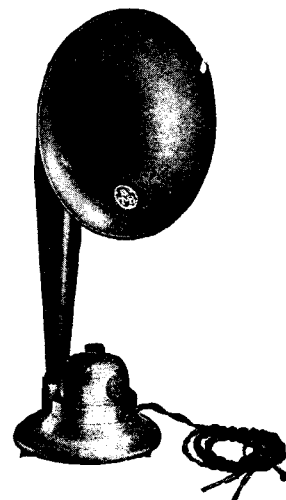

A B. T.-H. loud-speaker.

be possible to mask them with another set. The use of several loud-speakers in parallel is also most effective, and I hope to contribute a note on this subject in the near future.

**A Vicar's
Appreciation of
the famous All-
Concert Receiver.**

To the Editor of MODERN WIRELESS.

SIR,—As a keen student of MODERN WIRELESS since the first issue, I have built many of the sets described from time to time. The All-Concert set appealed to me specially, and having hurriedly built it, it gave excellent results—I have now made it up permanently into a cabinet, with a few modifications—I can use 1, 2, or 3 valves. Whilst experimenting a few nights ago I was surprised that I could pick up 2ZY some 60 miles away on one valve. I then tried the other stations of the B.B.C., and I picked up every station at good strength. I can now do this every night. As I consider this very fine reception I thought that you would like to know of it. I use an ordinary P.O. aerial which is badly screened both by trees and mountains. I may say that I took meticulous care in building the set, but I have been amply rewarded for any little extra trouble. Please accept my very best thanks and all good wishes.

Yours faithfully,
(Rev.) E. HUGHES.
Ruthin, N. Wales.

"Modern Wireless" Coil Table

For AERIAL, ANODE and REACTION COILS.

STATION.	WAVE-LENGTH (Metres).	COIL.								
		Burndept.			Gambrell.			Igranic or other numbered type.		
		Aerial.	Tuned Anode.	Reaction.	Aerial.	Tuned Anode.	Reaction.	Aerial.	Tuned Anode.	Reaction.
Amateurs, KDKA and WGY Amateurs	100 200	* 1st S ₁	* 2nd S ₂	* 3rd S ₃	* a ₂	* a	* A	25	25	35
Relay stations, Petit Parisien, American stations, 5WA, 2LO, 2ZY, 6BM, 5NO ..	300-400	S ₂ or S ₃	S ₄	75 or 100	A	B	C	25 or 35	50	75 or 100
Vox Haus, Brussels, Ecole Supérieure, American stations, British amateur stations, and 5SC, 5IT, 2BD	400-500	S ₃	S ₄ or 75	100	A	C	B or D	35 or 50	50 or 75	100
Rome and Shipping	600	S ₄	100	150 or 200	B	D	C or E	50 or 75	100	150 or 200
Aircraft stations, The Hague and Lausanne	800-1,100	75 or 100	150 or 200	250	C	E	D	75	150 or 200	250
Radiola	1,780	150	250	300	E	F	G	150	250	300
Madrid, Königswusterhausen, and Eiffel Tower	2,100-2,700	250	400	500	E or F	G	H	250	400	500
Königswusterhausen	4,000	400	500	600	G	H	I	400	500	600

COIL EQUIVALENTS.

Following Coils are numbered similarly:
Igranic, Atlas, Lissen, Burndept.

CONCERT COILS.—(Igranic, Burndept, Tangent, Magnum). The second usually covers British broadcasting for aerial, the third suits the anode, and the fourth the reaction socket.

MAGNUM TAPPED COILS.—These are tapped, each tap corresponding approximately to one of the numbered plug-in coils. No. 1 corresponds

to coils 25 to 75. No. 2 corresponds to coils 50 to 150.

GAMBRELL COILS.—A coil corresponds approximately to 25 or 35, B to 50, and C to 75, etc.

*SPECIAL SHORT WAVE COILS.—Burndept and Gambrell supply special short wave coils for 100 metres.

NOTE.—For 100 and 200 metre wavelengths aerial condenser should be in series.

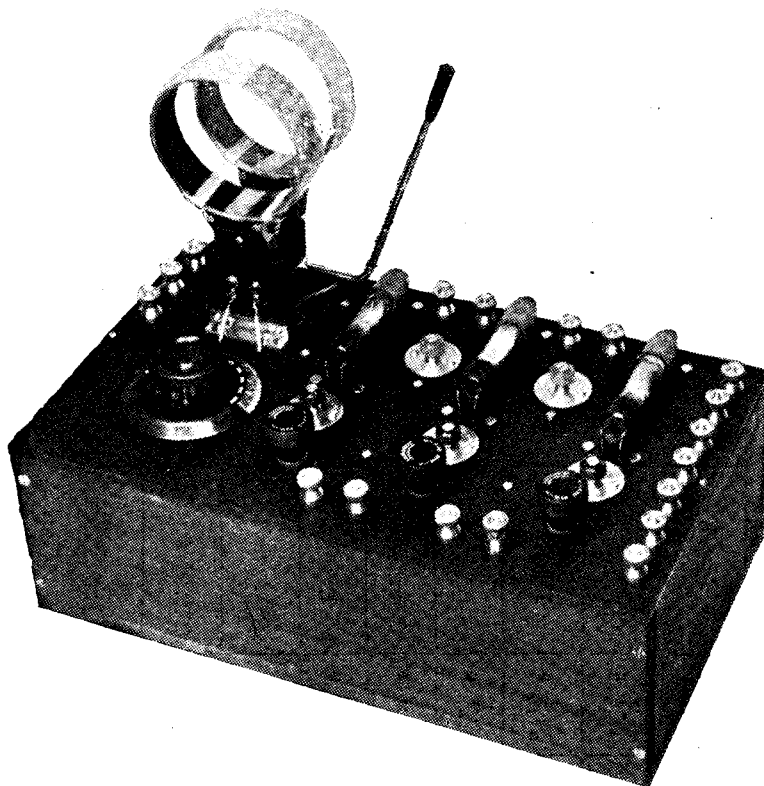

There is but one tuning control in this receiver.

A Distortionless Three-Valve Receiver

The Practical Application of Captain Round's Experiments

By PERCY W. HARRIS, Assistant Editor

NOTE.—In the April issue of MODERN WIRELESS we published an important and interesting article from the pen of Captain H. J. Round, the famous wireless expert. In this article Mr. Harris explains how he has built a receiver incorporating Captain Round's ideas in such a way that all of the experiments indicated in the article in question can be carried out with it. The particular instrument is, however, a finished receiver and does not need any further attachments to give excellent results.

BY a strange coincidence the article from the pen of Captain Round in our last issue coincided with the appearance of a description of my own resistance capacity coupled amplifier, which, as explained, could be used for either high or low frequency. Both of the circuits recommended by Captain Round use resistance capacity amplifiers, and it is therefore quite a simple matter for the reader who is experimentally inclined to add a valve detector to my own amplifier and obtain the circuit given by Captain Round. As, however, the chief object of Captain Round's article was to show our readers how to carry out some important experiments in distortionless amplification, it occurred to me that possibly many experimenters would like to have a design incorporating the circuit given in Fig. 2 of the article referred to, but so arranged with terminals that the necessary modifications could be made easily and effectively. I have therefore designed and built such a receiver, which is illustrated and described herewith.

Fig. 1 shows the circuit diagram, which is practically identical with that of Fig. 2, page 588, MODERN WIRELESS for April. There are, however, one or two practical modifications which are useful. For

example, the three-terminal method is adopted to give either series or parallel condenser for aerial tuning; one grid biasing battery is made to serve for both amplifying valves, whilst owing to the fact that no resistance is included in the plate circuit of the last valve, a separate H.T. terminal is provided for this so that the effective high-tension voltage can be approximately equal on all three valves.

All of the experiments described by Captain Round are carried out by making and using shunts across the resistance R_5 or R_6 and across the telephones. For this reason four terminals are provided at the rear of the instrument, two across

each of the resistances R_5 and R_6 . Any good valves can be used here, but by way of a change I have used the new Myers valves, which are now available on the British market. These valves are of Canadian manufacture, and are obtainable in two varieties, one a bright emitter requiring 4 volts and consuming about 0.6 of an ampere (on actual measurements the three valves in this receiver consume 2 amperes), whilst a dull emitter variety made up in exactly the same fashion uses 0.25 of an ampere at 2½ volts. Each valve is sold in a carton with a complete set of clips and a drilling template, thus it is not necessary to buy any valve-holders in this case.

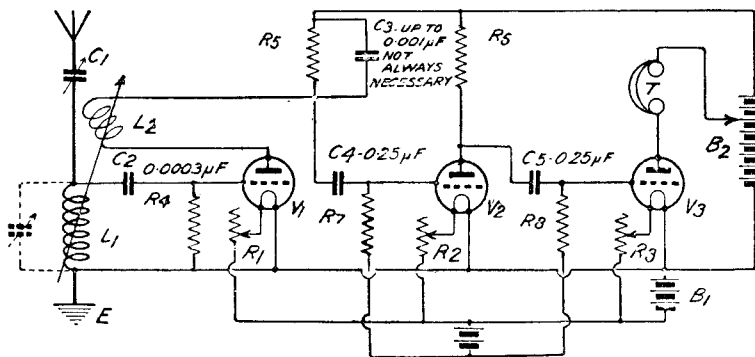
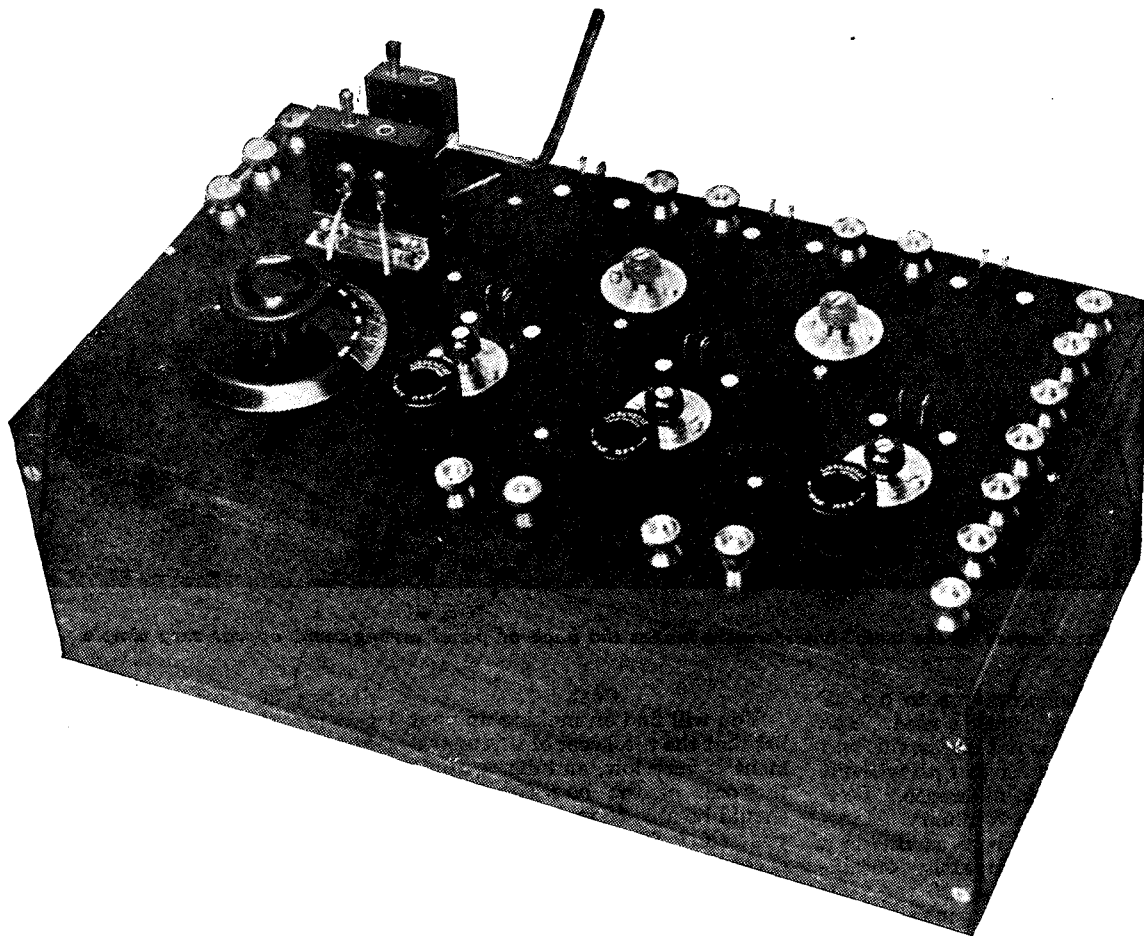

Fig. 1.—The circuit diagram. It closely resembles that given by Captain Round in last month's "Modern Wireless."



When the valves and coils are removed the construction and layout of the panel are readily seen. The back terminals are used only for experimental work.

Reaction coupling is obtained by the conventional plug-in coil of any suitable make, fixed in a two-coil holder mounted on the top of the panel. The variable condenser is of the square-law pattern, which, in my opinion, will eventually displace all other kinds of condensers. Square-law condensers are now sold by the Sterling Telephone Co., the Scientific Supply Stores, and the Bowyer-Lowe Co., Ltd. Others, I am told, are on the way. That used in the present instrument is a Bowyer-Lowe. The great advantage of a square-law condenser is that wavelengths equally spaced on a wavelength chart are equally separated on the condenser scale. With the ordinary condensers the lower part of the scale is greatly congested, and the upper part correspondingly opened out. Thus, if we have a condenser of, say, $.0005 \mu\text{F}$, which will tune from, say, 300 to 500 metres, to take an arbitrary case, wavelengths from 300 to 400 will be contained in the first quarter of the scale,

whilst wavelengths of 400 to 500 will be spread over the second part—*i.e.*, three-quarters. With a square-law condenser 300 to 400 metres will occupy the first half of the scale, whilst 400 to 500 will occupy the second half. Furthermore, a great advantage is that in tuned anode circuits, tuned transformer circuits, or wavemeter circuits and others similar, it is only necessary to pick up any two wavelengths which are known and then to mark the positions on a chart the bottom of which is divided into degrees from 0 to 180 and the left-hand vertical column in metres. Having made points on such a chart for two known wavelengths in the positions indicated, we have only to join these points with a ruler and to project the line right across the scale. We shall then have a straight line "curve" which will enable us to find accurately the positions of any other wavelengths on our condenser scale. The problem of calibrating a receiver is thus immensely simplified.

Components Required

The following are the components required:—

- Ebonite panel measuring 14 in. by 8 in. by $\frac{1}{4}$ in.
- 1 box $4\frac{1}{2}$ in. deep (the box is identical with that used in my 3-valve Reinartz receiver in the Spring Double Number).
- 18 terminals (W.O. pattern).
- 1 two-coil holder (that shown is a Magnum).
- 1 variable condenser $.0005 \mu\text{F}$ (that shown is a Bowyer-Lowe square-law, although the ordinary type of condenser will be just as efficient, if not quite so convenient).
- 3 valves, with sockets (those shown are the Myers Universal, but any good valves will do).
- 3 variable grid-leaks (Watmel).
- 2 variable high resistances (50 to 100,000 ohms) (Watmel).
- 3 filament resistances (any good type will do here suitable for the valves used. Those shown are Lissenstats).
- 1 fixed condenser $.0003 \mu\text{F}$.

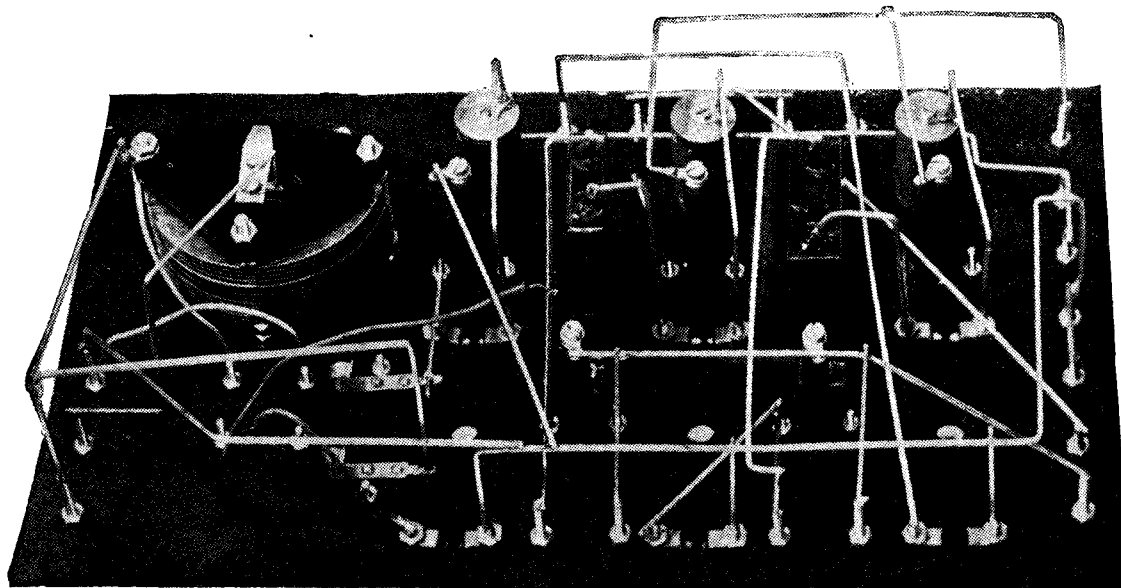

The absence of the usual transformers makes the back of panel arrangement appear very simple.

2 fixed condensers 0.2 to 0.3 μF (Mansbridge type is used. The exact value is not important, and can run from 0.1 to 1 μF without any noticeable difference. I recommend the ordinary Mansbridge 0.25 μF here as this is a commercial type easily obtainable).

Quantity of No. 16 gauge square-sectioned tinned-copper wire for wiring up (this is obtainable from a number of firms now advertising in this journal and *Wireless Weekly*).

Cost

You will find on making up your list that the total cost of this instrument is very low, and disregarding the cost of the box (which you should be able to make quite easily yourself for a few shillings) and excluding the valves, you should have some change out of £3 10s.—a very reasonable figure for a 3-valve set.

Fixed Condensers

In my resistance amplifier described last month I used for the audio-frequency side fixed con-

densers of .006 μF . There were two reasons for using this value. First of all, it is quite a suitable value for low-frequency work, and, secondly, it is easily obtainable in a form which will slip into the clips shown. Captain Round, in his article, specifies much larger condensers, and I have used them in this set, but I do not find any appreciable difference by so doing. Careful examination of the photographs will show that the two fixed condensers are not of exactly the same size. This is due to the fact

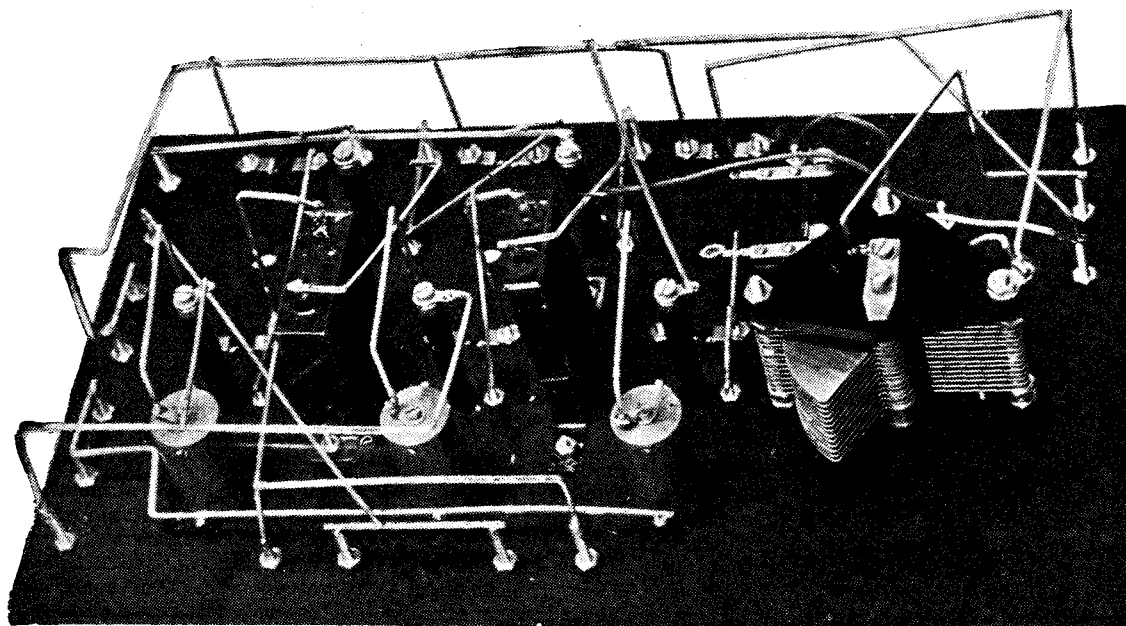

In this view, taken from another angle, any remaining doubts about wiring are removed.

that these two were two I had available at the time of making up the instrument. I recommend the use of a pair of equal capacity of, say, 0.25 μF . If you have already made up the resistance amplifier described last month there is no need to change your capacities from those given. I have simply used the larger value in the new receiver because Captain Round mentioned them in his circuit diagram.

Starting Work

Use a good quality ebonite panel, and if the ebonite is not guaranteed free from surface leakage (fortunately such ebonite is now obtainable at a reasonable price), you

for this advice, the most important being that there is always a chance of slight differences in the sizes of the holes required and in their disposition. It is much the best way to take a particular component (for example, a Mansbridge condenser) and to stand it on the back of the panel in the position it is to occupy. Then take a scribe or other sharp-pointed instrument and scratch the ebonite through the hole in the condenser mounting. Do this carefully without shifting the position of the condenser and you will get two marks which will show you exactly where to drill. Having made these marks, make a small depression, exactly in the centre of the little circle so scratched,

central rods of the leaks and resistances, you can place these items in position, and similarly scratch through the holes in the brass top-plates for the purpose of locating the drilling centres.

When the panel is drilled the various components can be secured by, in the case of the condensers, the screws supplied with it, and in the case of the other parts by 6 B.A. metal screws and nuts. The 6 B.A. metal screws can be obtained either "cheese-headed" or with countersunk tops. To mount the cheese-headed screws nicely it is necessary, after drilling the usual clearance hole, to select a drill the diameter of which is exactly equal to that of the head and to drill a hole for just

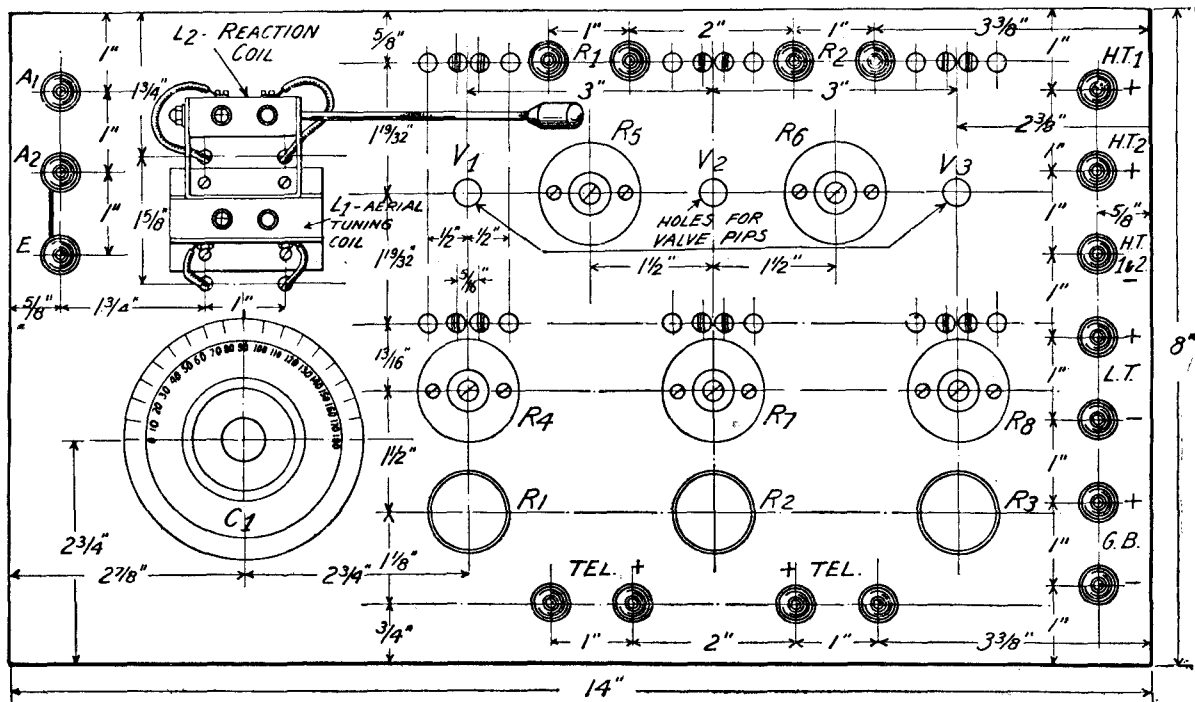

Detailed and dimensioned layout of panel top. The terminals marked R₁ and R₂ are used for Captain Round's experiments.

should rub down the surface on both sides with fine emery to remove all signs of the surface skin. A touch of oil on a soft rag rubbed all over the ebonite will remove the dirty brown look resulting from rubbing with emery cloth. You can then scratch out on the back of the panel with the aid of a scribe (if you have not one a needle fixed into a wooden handle will do) the positions of the various component parts. If you obtain the full size blue print mentioned at the end of the article such marking out will be very simple.

I do not advise you to attempt to drill the panel before you have all your components at hand. There are several reasons

with the aid of a sharp-pointed nail and a hammer, to take the point of the drill. If you do not do this, but attempt to drill straight in the middle of the scratched circle, the chances are that the point of the drill will wander and your hole will not be properly centred. Small devices known as centre punches are sold for the purpose of making these central depressions, but are not absolutely necessary. Personally I find a centre punch a very useful tool, and as it only costs a few pence, it is just as well to buy one when you begin to make wireless instruments.

Having drilled the holes for the

the depth of the head of the screw. This will enable the head to bed into the panel flat. If you use a countersunk head you will need either a countersink bit to cut the ebonite to take this head, or, failing this, the end of a very large drill can be used quite effectively for the same purpose. A 3/8-in. drill is very useful, for it can be used to drill the holes for the Watmel resistances and leaks, for the Lissenstat mounting, and for the centre holes to take the pips of the Myers valves. (The method of mounting these valves is clearly explained on every carton, so that no details need be given here.) If you use the ordinary four-pin valves I strongly

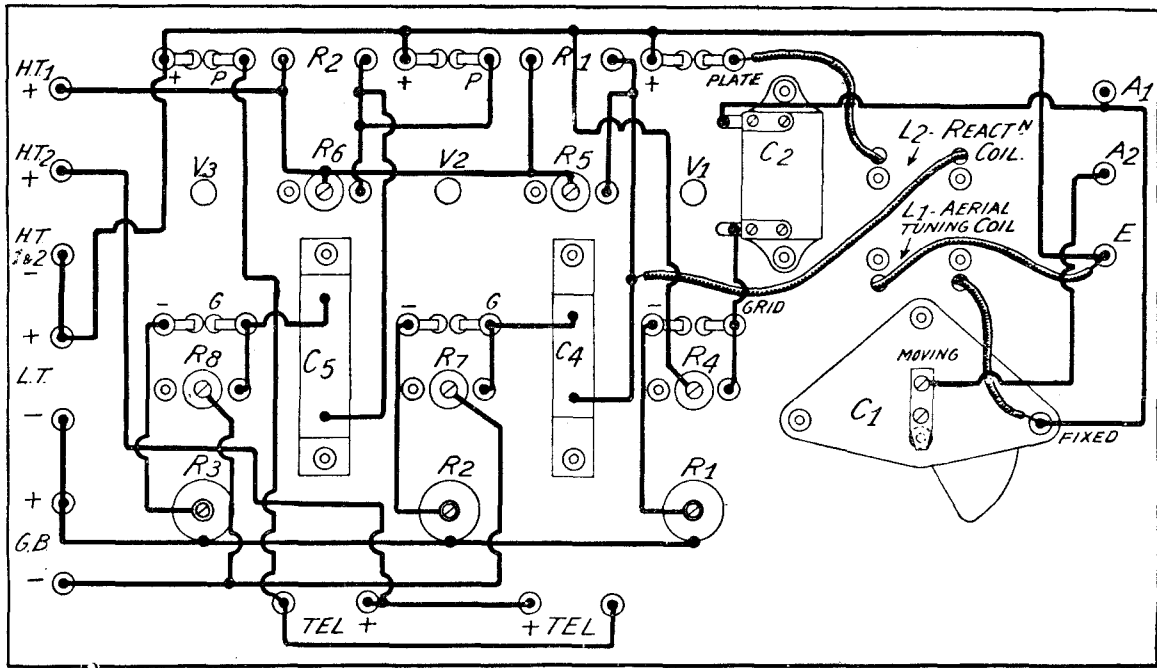

As the mountings of the Myers valves are unusual, grid and plate terminals are clearly marked.

recommend you to use a drilling template to mark the positions of the valve legs accurately, or, failing this, to use the ebonite mounted sockets so readily obtainable. A No. 26 Morse drill will drill clearance holes for 4 B.A. screws, such as are used for terminals, condenser mountings, etc., whilst a No. 34 Morse drill will serve to make the clearance holes for the 6 B.A. metal screws used to mount the various components.

Wiring Up

Wiring up should present no difficulties from the illustrations and diagrams published herewith. Wiring up with square-sectioned bus-bar wiring is not difficult, particularly if you bend the wires to shape before soldering on. It is quite fatal to attempt to bend them after soldering one end, as you will inevitably break the soldered connection. I do not recommend the use of flexible wire and Systoflex tubing in the present instrument. In order to make sound attachment to the resistances and leaks I have used soldering lugs. These are now readily obtainable from a number of dealers.

In this receiver note particularly the connections to the fixed and the moving plates of the condenser. It is always advisable to connect the moving plates to the earth side, as you will then get less effect from hand capacity when tuning the set. It will be noticed that there are

three terminals for aerial and earth connections, two being joined with a link when it is desired to use the condenser in parallel. To place the aerial tuning condenser in parallel with the plug-in coil, connect the aerial to the upper terminal and join the two lower terminals with a wire, taking the earth connection from either of them. For working with the aerial tuning condenser in series disconnect the link, place the earth wire on the lowest terminal and the aerial connection on the middle terminal. The condenser will then be in series. This arrangement of three terminals obviates the necessity of introducing a series parallel switch. For 100-metre reception, such as KDKA and WGY and many amateurs, you will, of course, need a condenser in series.

Operation

When you have finished all your wiring, first of all connect up the low-tension battery and try to see whether your filament connections are correct. You can try this by turning the filament resistances slowly in a clockwise direction and see whether the valves light up properly and are properly controlled. If these connections are correct, connect the high-tension battery to the terminals shown. It will be noticed that there are two terminals of positive H.T. The upper terminal goes to the first two

valves, and the terminal immediately beneath goes to the last valve. Not less than 120 volts should be connected to the uppermost high-tension terminal, the negative lead from which battery is connected to the common low-tension negative. About 80 volts is suitable for the last valve in these conditions, and can be a tap off the same H.T. battery. In case the reader may wonder why two different voltages are used here, it should be explained that there is no high resistance in the anode circuit of the last valve, and consequently, if the same voltage were applied throughout, the last valve would really have a higher voltage on its plate than the preceding two owing to the voltage drop in the high resistances of the first two anode circuits. A 4½-volt dry cell battery should be connected to the grid bias terminals, and a pair of high-resistance telephones or a high-resistance loud-speaker to the telephone terminals.

Coils to Use

For British broadcasting the condenser should be used in parallel with a No. 25 or 35 coil for the lower wavelength, and a No. 50 for the upper, if coils so numbered are used. If so-called "concert" coils are used, then you will need the second or the third of the particular series for British broadcasting. In Gambrell coils the

The Valve as an Efficient Detector

By JOHN SCOTT-TAGGART, F.Inst.P., A.M.I.E.E.

Not merely a theoretical article, but one which will enable you to get more out of your present set

VERY little has been written about the valve as a detector. Perhaps this is because a proper explanation of the action of the leaky grid condenser is difficult to give, and if given, most readers would find it troublesome to follow.

A method of explaining the phenomenon, which no other author has used, is given in the following article. The explanation is very simple without any sacrifice of technical accuracy.

Several factors govern the operation of a detector valve, and the correct choice of high-tension voltage, filament current and grid potential is essential if the best results are to be obtained. Most experimenters treat their detector valves as they would an amplifying valve, and while good results are obtainable under many conditions, yet to obtain the last ounce out of a set, for long distance work, the detector valve should be treated separately. The detector valve is, in fact, the weak point in every valve set, and it matters little how much high or low-frequency amplification there is if the detector valve is not working efficiently.

The fundamental principle of the three-electrode valve working as a detector on the leaky grid condenser principle is entirely different from that when no grid condenser is used. Rectification may certainly be obtained without a grid condenser, but the results are usually not nearly as good as when the more usual arrangement is employed.

It is proposed in this article to

deal purely with the grid condenser method of rectification which, although practically the only one used to-day, receives a minimum of attention in the technical press.

The secret of understanding how leaky grid condenser rectification takes place is to appreciate that a valve, working in this way, is really acting both as a detector and amplifier. The three-electrode

in both cases saves us having two separate valves, but otherwise the action remains the same. The only complaint against the convenient arrangement of merging the two valves into one is that the conditions for good amplification are not necessarily the same as those for good rectification, using the Fleming valve principle.

Fig. 1 shows an ordinary, simple

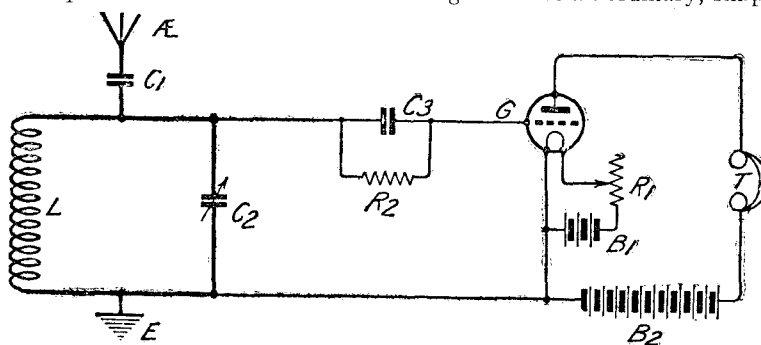

Fig. 1.—A simple valve detector circuit.

valve, acting as a detector using a leaky grid condenser, really consists of two valves merged into one, the first of these valves being a two-electrode valve using an anode and a filament, and the second being a plain low-frequency amplifier.

The grid, in the three-electrode valve, carries out two functions; in the first place it acts as the anode of a two-electrode valve, which really consists of the filament and the grid, and it also acts as the control electrode for the second valve, which consists of the filament, grid and anode. The fact that we use the grid and filament

detector circuit in which a condenser C_3 of $0.0003 \mu\text{F}$ capacity is connected next to the grid of the valve, a resistance R_2 of about 2 megohms (2 million ohms) being shunted across this condenser. The inductance for broadcasting purposes may be a No. 50 coil, while C_1 is a fixed condenser of $0.0001 \mu\text{F}$ capacity. This is the constant aerial tuning condenser which has been advocated frequently in these columns.

An interesting experiment to try with this circuit is to disconnect the lead to the anode of a valve and to connect a pair of high resistance phones in place of the condenser C_3 and the resistance R_2 . Weak signals should still be heard indicating that the grid circuit of the valve is rectifying.

We now have an arrangement which is virtually the same as that illustrated in Fig. 2. We have a filament F and an anode A, which in Fig. 1 is replaced by the grid, the only difference being that, in the case of Fig. 1, the grid consists of a spiral of wire, whereas in Fig. 2 the anode would usually consist of a plate of metal, or a cylinder similar to the anode in a three-

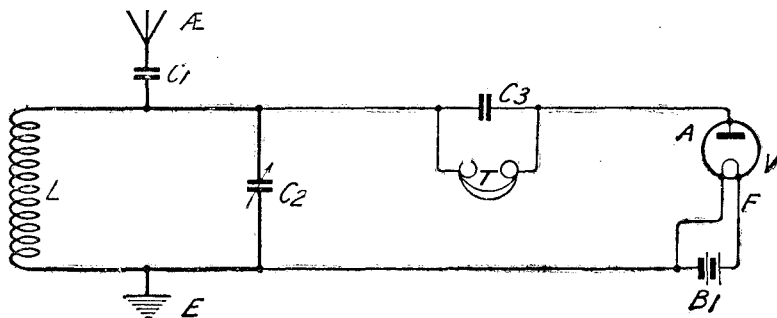

Fig. 2.—An interesting experiment with a Fleming valve.

electrode valve. The type of valve illustrated by V in Fig. 2 is a two-electrode valve, or Fleming valve, which was the first type of valve used for detecting wireless signals in 1904. Those who desire to try experiments with a Fleming valve have only to use an ordinary valve and leave the anode disconnected and use simply the grid and filament, or alternatively, the grid and

phones T respond to the average effect of the impulses which follow each other, perhaps at the rate of half a million times per second. The currents which flow through the telephones T set up potential differences across the ends, and it is these potential differences which, in the case of a circuit such as Fig. 1, are amplified by the three-electrode valve.

ment, but no electrons are drawn to the anode; on the other hand, they are repelled. The second positive half-cycle now comes along, and, overcoming the slight negative potential, once more raises the anode to a potential above that of the filament, and consequently the positive potential on the anode draws up more electrons which, at the end of the positive half-cycle, leave the anode still more negative.

This process continues until the positive half-cycles are insufficient to overcome the gradually increasing negative charge on the anode, and when this occurs the anode obviously does not become positive, and so no more electrons are drawn up to the anode, the grid remaining at an average negative potential, which would remain there indefinitely were it not for the fact that the resistance R_2 , which acts as a leak, allows the electrons to leak round from the anode of the right-hand side of the condenser C_3 , through the inductance L, back to the filament. If the leak R_2 is high, it may take some considerable time before the negative charge on the anode leaks away. Consequently we note in the second line of Fig. 4 that the dotted line, which rises up to the zero line, representing the zero grid voltage, remains even after the end of the series of oscillations we are considering.

In actual practice the resistance R_2 may conveniently be adjustable, in which case we can extend or

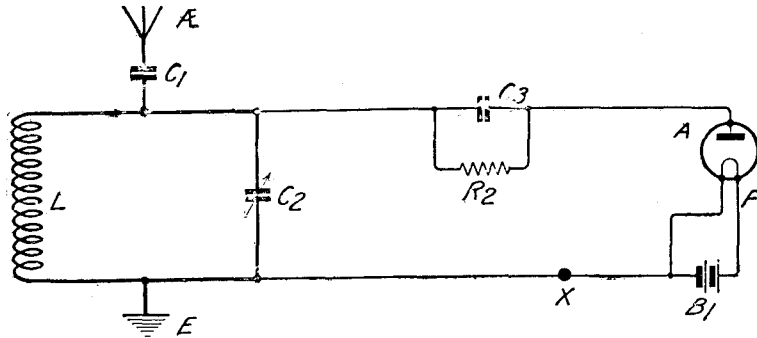

Fig. 3.—A modification of the Fig. 2 circuit.

anode may be connected together and used as the anode of the valve.

The arrangement of Fig. 2 will act as a detector, and it will be seen that the telephones T have been connected in the anode circuit and are shunted by a condenser C_3 which may have a capacity of $0.0003 \mu\text{F}$. The action of the circuit is really very simple. The high-frequency currents across the circuit $L C_2$, are communicated to the anode of the valve, which is made first positive, and then negative, with respect to the filament, the changing being at high-frequency. When the anode A is made positive, with respect to the filament, electrons, which are shot off from the filament, are drawn up to A and an anode current is produced, which flows through the telephones T. When, however, the anode A is made negative by a negative half-cycle of the oscillating current in $L C_2$, no electrons flow from filament to anode. The high-frequency currents are therefore rectified, and we have a series of weak impulses all in a given direction, flowing from the anode A, through the telephones T, round through the inductance L and back to the filament. When receiving broadcast signals, or spark signals, the high-frequency currents in the receiver are continually fluctuating, and when these fluctuating currents are rectified we have a direct current which is fluctuating at low-frequency, these fluctuations passing through the telephones T, producing the particular sound.

As a matter of fact, in a circuit such as that of Fig. 2, the tele-

We may modify the Fig. 2 circuit by connecting a high resistance of, say, 2 megohms value across the condenser C_3 in place of the telephones T. The current through the resistance R_2 in Fig. 3 will now be the rectified low-frequency currents, and the right-hand side of R_2 will have its potential varied with respect to the left-hand side, by the flow of the rectified current; these changes of potential will take place at low-frequencies corresponding to the speech or music being received. Simultaneously, of course, there are fluctuations at high-frequency, due to the high-frequency currents in $L C_2$ being communicated through the condenser C_3 to the anode A of the valve, but we are not immediately concerned with these high-frequency currents.

Fig. 4 gives some indication, graphically, of the effect obtained with a circuit of the Fig. 3 type. The upper line indicates the original high-frequency oscillations, or rather, a few of them, showing the variation in strength which is always occurring when receiving spark signals or broadcasting. The second line indicates how the anode potential of the valve in Fig. 3 varies. At first it is made positive, and electrons are drawn from the filament to the anode; these electrons charge up the right-hand side of the condenser C_3 and the anode, which consequently, at the end of the first positive half-cycle, is slightly negative. The negative half-cycle now comes along, and the anode is made still more negative with respect to the fila-

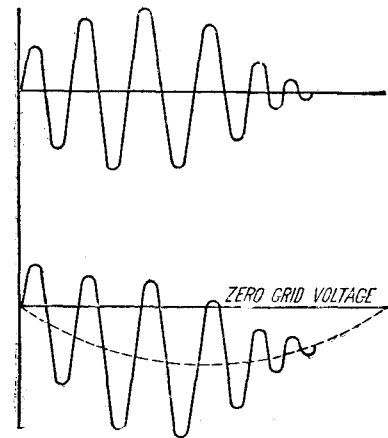

Fig. 4.—Showing what happens in the circuit of Fig. 3.

limit this after effect, which in some cases is desirable, but in other cases may lead to a slurring together of groups of oscillations.

We will therefore see that when using a circuit of the Fig. 3 type the anode A will have its potential varied with respect to the filament at audible frequencies, although at the same time its potential will be

fluctuating at an enormously greater rate, due to the high-frequency potentials communicated through the condenser C_3 . The beginner may imagine a man compressing with his hand a strong spring, one end of which is on the ground. Great strength is required to compress this spring, and the man's hand trembles as he pushes the end downwards. The movement of the top of the spring downwards is a slow one, but at the same

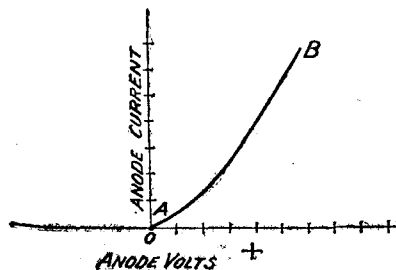

Fig. 5.—Anode current characteristic curve.

time there are "high-frequency" tremblings. If the bottom of the spring were placed on someone's body who was being slowly squashed, the fact that there were tremblings would not worry him very much; he would be chiefly concerned with the slow, steady pressure. So, in the same way, we are only concerned with the slow low-frequency changes of potential of the anode A in the Fig. 3 circuit.

These, it is to be noted, always cause the anode potential to fall below the normal potential. In other words, the rectification process results in the anode becoming negative to a varying extent in sympathy with the incoming varying high-frequency currents. The anode is never made positive by the rectification process.

It is important to notice here also that the anode should, under normal conditions, be at zero volts when no signals are arriving. A glance at Fig. 5 will make the reason for this quite plain. This figure illustrates an anode current characteristic curve, the horizontal line indicating anode volts and the vertical line the anode current which corresponds to different anode voltages. The characteristic curve starts at zero at the point A, and continues towards B and beyond it. A negative potential on the anode would result in no current flowing in the anode circuit, so that the curve stops at the point A. If we place a negative voltage of, say, -2 volts on the anode, any incoming high-frequency currents of ordinary strength would never make the anode positive, with the result

that there would be no flow of electrons to the anode and no piling up of a negative charge on the anode; there would be no rectification effect at all. If, on the other hand, we place a positive potential on the anode by connecting, for example, a battery at the point X in Fig. 3, rectification effects will once more be missing, because there would be a steady anode current flowing round the anode circuit, and the incoming high-frequency currents would increase or decrease this current by similar amounts.

We can say all this far more scientifically by stating that rectification will only be obtained when the valve is operated at a bend in the anode characteristic curve (it must be remembered that we are now referring to the two-electrode valve). As a matter of fact, the best point is not always that which corresponds to zero volts on the anode. Sometimes a point slightly to one or other side of zero volts gives best results. In practically every case it is better to have the anode just slightly positive. This effect may be obtained in the Fig. 3 circuit by making the connection, not to the negative terminal of the

exactly the same way as the anode A of Fig. 3. When signals are being received, the grid G has its normal potential, which is in the neighbourhood of zero volts, reduced to negative values of varying strength, owing to the accumulation of electrons on the grid and the right-hand side of the condenser C_3 . If now we join the terminals Y Z in Fig. 6 we will not materially affect the operation of the grid circuit, but, on the other hand, the addition of the anode circuit introduces a stage of low-frequency amplification.

If we join Y to Z we arrive at the circuit from which we started—namely, Fig. 1. The periodical drop in potential of the grid G at low-frequency repels a certain number of electrons which would have gone to the anode, and the result is that the anode current will fall periodically below its average value in time with the fall in grid potential. Owing to the delicate control of the grid, the small changes of potential on this control electrode will result in large decreases of anode current, and therefore the simple arrangement of Fig. 3 has added to it a stage of low-frequency amplification.

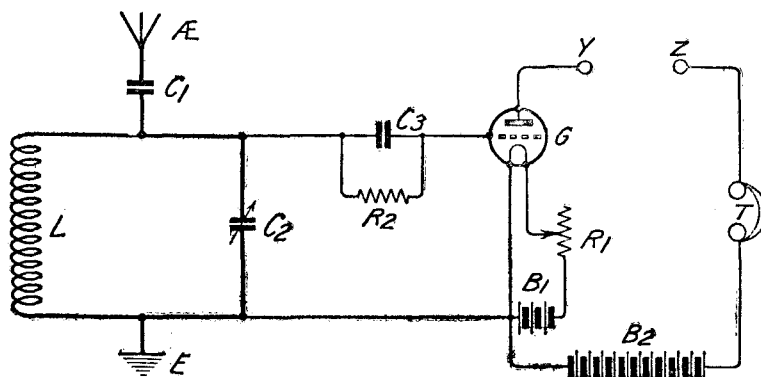

Fig. 6.—How a three-electrode valve can be used to give the same effect as Fig. 3.

filament accumulator B_1 , but to the positive terminal. Owing to the high resistance of R_2 , it must not be supposed that the full voltage of the battery B_1 is communicated to the anode.

Fig. 6 illustrates how a three-electrode valve may be used to give the same effect as Fig. 3, which latter figure, of course, would not receive signals because there are no telephones connected in the circuit. In Fig. 6 the only change that has been made is to substitute a three-electrode valve for the two-electrode valve of Fig. 3, but to leave the anode circuit disconnected, so that the grid G of Fig. 6 acts in

The adjustment of the high-tension voltage in a circuit of the kind illustrated in Fig. 1 is of considerable importance. If the high-tension voltage is too high, the electrons will travel with great speed between the filament and the anode, and the small positive half-cycles being applied to the grid will not materially alter the course of electrons on the way to the anode. The higher the anode voltage, the greater the positive potential which has to be applied to the grid to snare electrons from the direction of the filament or from the main stream towards the grid. Since the whole essence of grid current

rectification lies in the fact that the grid is to attract electrons, it will be seen that if we make it difficult for the grid to attract electrons by making the anode too great a counter-attraction, poor signals will be the result.

An insufficiency of electrons, due to too low a filament temperature, will also result in poor signals.

So much for the rectification problem in the grid circuit. The next point to consider is the amplifying of the rectified potentials on the grid, and here again it is very important to see that the filament current and anode voltage are suitably adjusted. The best conditions for amplification are that the anode voltage should be fairly high to enable a steep characteristic curve to be obtained, and that the representative point—*i.e.*, the point on the curve which represents particular conditions at any given moment—should travel on a steep, straight portion and should not have to travel round bends or near bends in the anode current curve.

Fig. 7 shows what is really the equivalent of the ordinary three-electrode valve being used as a detector. The valve V_1 is the

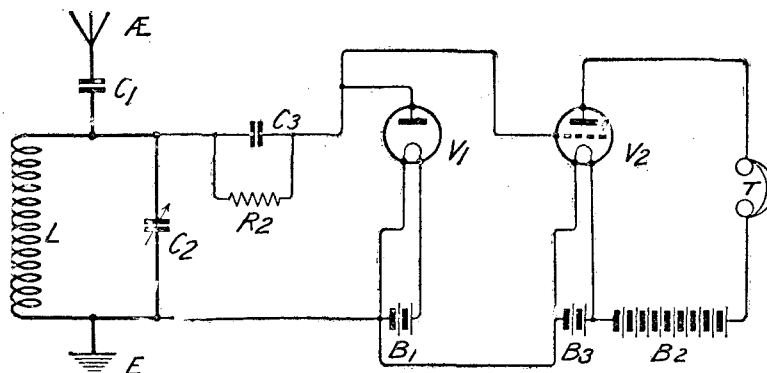

Fig. 7.—The equivalent of the three-electrode valve being used as a detector.

Fleming valve, while V_2 is a three-electrode valve acting purely as an amplifier. The potential changes on the anode of the first valve, due to the accumulation periodically of electrons on it and on the right-hand side of the condenser C_3 , are communicated to the grid G_2 of the second valve, which is connected to the anode of the first. High-frequency potentials are communicated to the grid of this second valve, but they do not enter into the action of this valve in any way.

On the other hand, the low-frequency potentials are communicated to the second grid and are amplified by the second valve.

An explanation of the action of detection would not be complete without reproducing the curves in Fig. 8 and Fig. 9. Fig. 8 shows a typical characteristic curve suitable when using a valve as a detector. Under these conditions the anode voltage is not too high, and the point F, corresponding to zero volts on the grid, is an excellent one. As

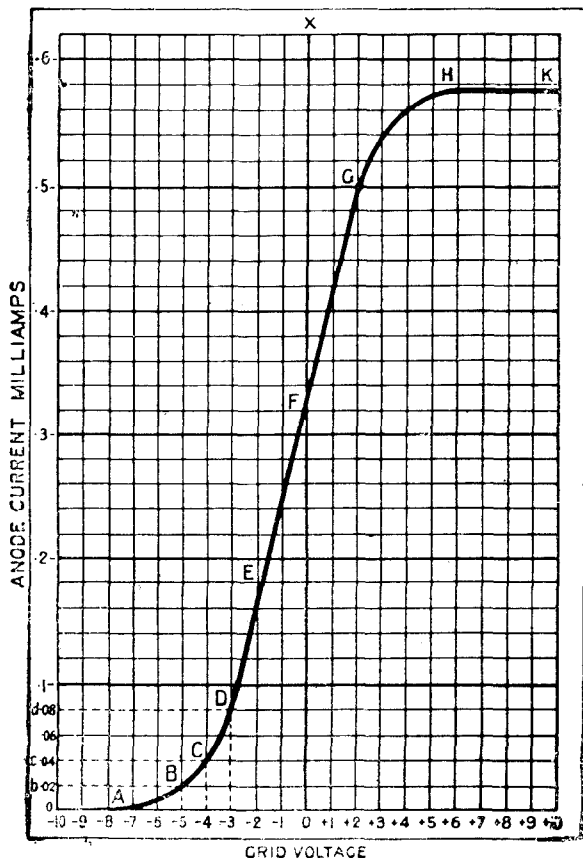

Fig. 8.—A typical characteristic curve suitable when using a valve as a detector.

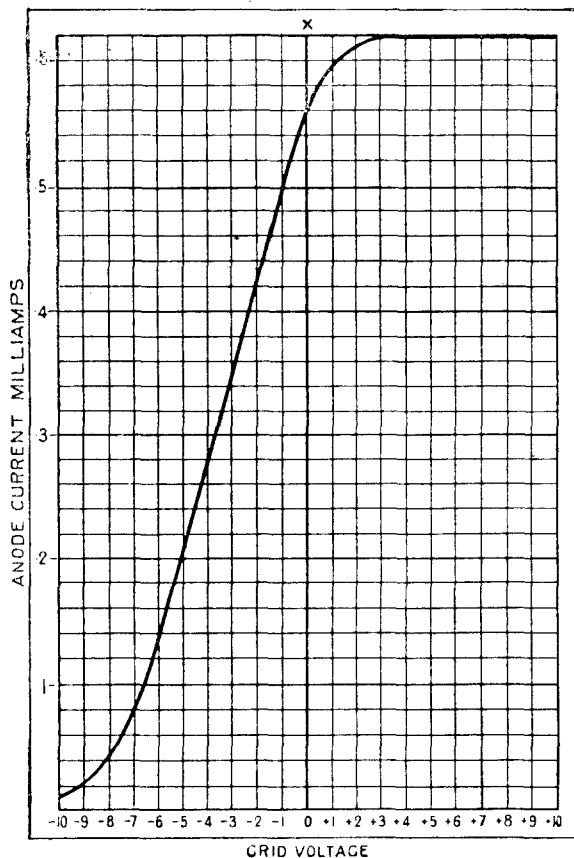

Fig. 9.—A suitable curve for low-frequency amplification.

the grid accumulates a negative charge, the anode decreases; in other words, the representative point travels from the point F on the curve towards the point E, and this corresponds to a large decrease in the anode current. It must be remembered that this kind of a curve is not so good as the Fig. 9 curve for low-frequency amplification when using transformers. When, however, we are dealing with a valve detector, it must be remembered that the grid does not have any low-frequency positive half-cycles applied to it, but only becomes negative to a varying extent.

Our chief consideration, therefore, is to see that the portion of the curve E F which comes into play is steep and straight.

If we use too high an anode voltage, the grid current set up when the grid is made positive will be considerably less, as already explained, but from the point of view of amplification, there would be no serious objection to the use of the curve of Fig. 9. Here again it must be remembered that although Fig. 9 would be quite hopeless as a curve for low-frequency amplification if the normal grid voltage were zero, yet in the case of a detector valve the grid potential variations are always in a negative direction. If a still higher anode voltage were employed the characteristic curve would fall

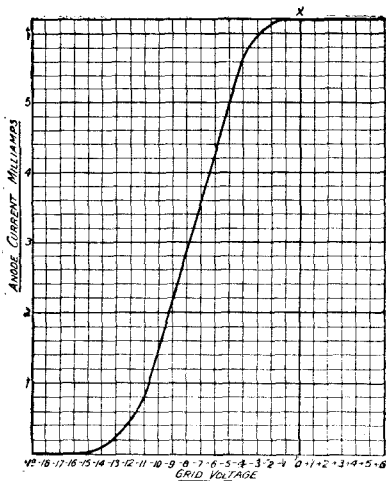

Fig. 10.—Another curve suitable for use when amplifying.

more to the left, and in this case zero grid volts would pass through the top bend, or saturation bend, of the curve, which would be quite unsuitable for amplifying the potential changes of the grid.

Such a curve is shown in Fig. 10. If we go to the other extreme and have a very low anode voltage, the rectification effect in the grid circuit may be very good, but the degree to which the potential changes on the grid will be amplified will be very small.

best results out of a detector valve, so that the only solution is to have a tapping from the high-tension battery.

Fig. 11 shows a circuit which will give very effective results, and should work a loud-speaker comfortably 10 miles from a broad-

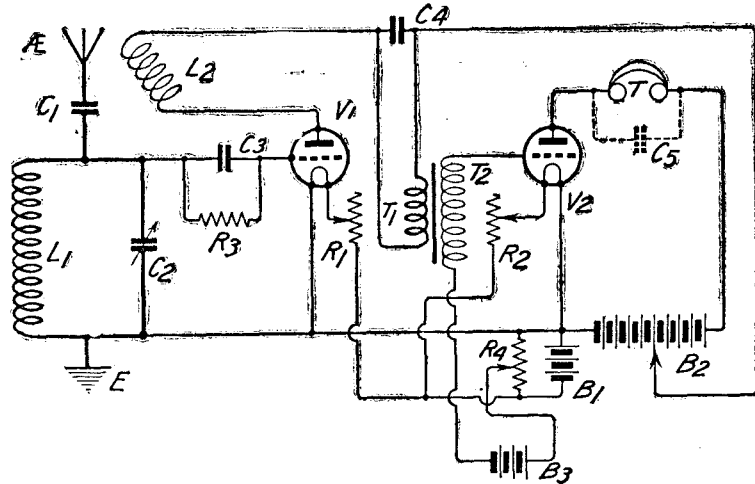

Fig. 11.—A circuit giving very effective results.

From these remarks it will be seen that some sort of compromise has to be arrived at, and that perfect detection in the grid circuit and excellent amplification in the anode circuit cannot be obtained. Nevertheless, by using a medium anode voltage on the detector valve, the results obtainable are very satisfactory, the curve of Fig. 8 being the type which will usually give the best results.

Many experimenters—including myself, incidentally—use the same anode voltage for their detector valve as for their low-frequency valve. This is very convenient, because only one positive high-tension terminal is necessary on the set, but to get the most out of a receiver it is really better to have a separate tapping on the high-tension battery from the detector valve, a lower high-tension voltage being used for this valve than for the other stages.

This particularly applies where a detector valve is followed by one or more stages of low-frequency amplification. In the latter case, the best characteristic curve for use is Fig. 9, or even Fig. 10, a suitable negative potential being applied to the grid of the amplifying valve, so that the normal operating point is about half way along the steep, straight portion of the curve. Unfortunately, both these curves are unsuitable for obtaining the

casting station. It will be seen that a tapping is taken from the high-tension battery B_2 , so that the anode voltage of a first valve is not too high, whereas the anode voltage of a second valve is sufficiently high to obtain a characteristic curve of the kind illustrated in Fig. 9, a negative potential being given to the grid of the second valve by means of a battery B_3 , the positive terminal of which is connected either to the negative terminal of a filament accumulator, or to the moving contact on the potentiometer resistance R_4 . If the battery B_3 has a voltage of 6 volts, the grid potential of the second valve may be varied from zero to -6 volts smoothly. The condenser C_4 has a capacity of $0.0002 \mu\text{F}$, while C_5 , which is usual if a loud-speaker is employed, should have a value of $0.002 \mu\text{F}$ or $0.004 \mu\text{F}$. The battery B_2 may have a value of 100 volts, in the case of bright emitter valves, and about 75 volts in the case of dull emitter tubes. Both inductances, L_1 and L_2 , may be No. 50 coils which should cover the whole broadcast waveband.

In this circuit, the high-frequency variations of grid potential as well as those of low-frequency are utilised, the currents being amplified and fed back into the grid circuit to produce a reaction effect.

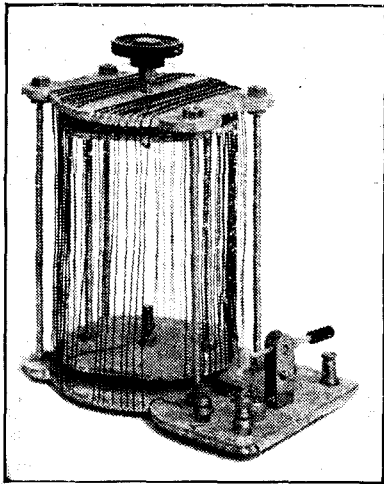

A photograph of the set.

THE crystal receiver which is the subject of the present article possesses a novel form of variometer and a catwhisker of a somewhat unusual type. It is a very compact and thoroughly efficient. Moreover, it is easy to make and of very pleasing appearance when finished. No ebonite is used in its construction, three-ply wood being used throughout to support the wiring and the component parts.

Fig. 1 is a plan of the baseboard, which was cut from a sheet of three-ply wood with a small fret-saw. All necessary measurements are given in the figure. This baseboard formed part of the stator of the variometer, the wire (No. 22 enamelled) being wound into the saw-cuts, which are indicated in the figure. These saw-cuts were made with a hack-saw, and it is worth

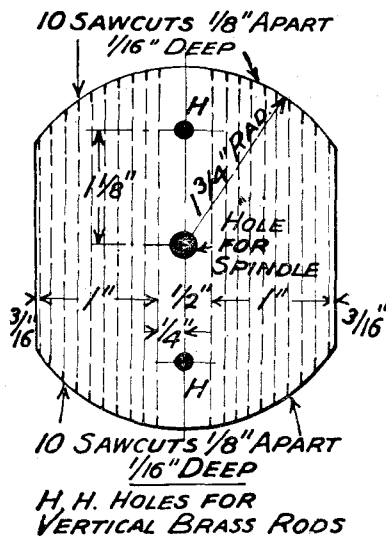

Fig. 2.—Plan of the base of the rotor.

A "Cage" Variometer Crystal Set

By E. H. CHAPMAN, M.A., D.Sc.
(Staff Editor)

Novel windings and a new type of catwhisker are the distinguishing features of this crystal set. Full constructional details are given.

noting how the wood was marked with straight lines running across the baseboard from side to side, the lines being $\frac{1}{8}$ inch apart. By making each saw-cut in the

top of the instrument by two nuts and to the baseboard by two nuts, one on either side of the wood in each case.

Fig. 2 shows, in plan, the base

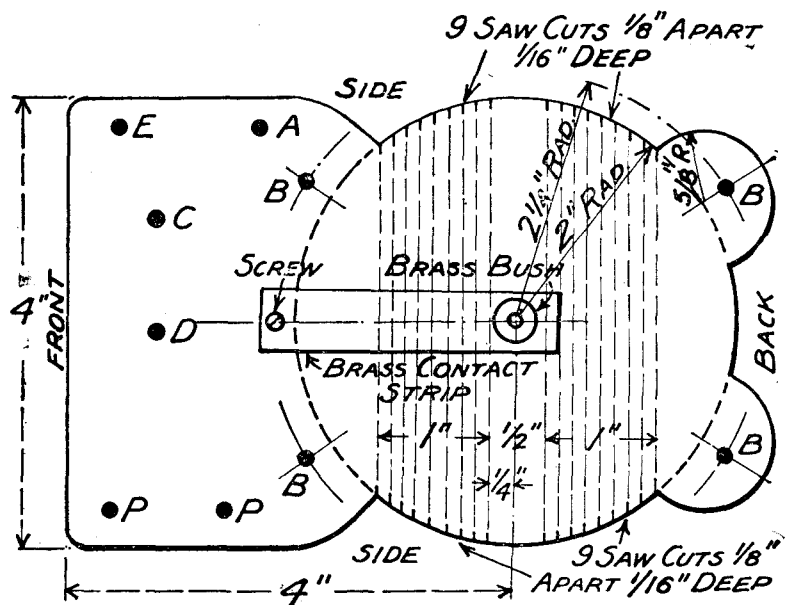

Fig. 1.—Plan and details of the baseboard.

direction of the line at the point where the cut was to be made, it was ensured that the cut should be in the exact direction of the desired winding at that point.

Fig. 3 is a plan of the top of the receiver. It will be seen that the top is, in part, a copy of the baseboard.

When finally assembled, the baseboard and top of the instrument formed the framework on which the wire of the stator of the variometer was wound. To fix the baseboard and top rigidly in position, four brass rods with screw-thread were cut, each rod being 6 in. long. These rods ultimately passed through the holes in both baseboard and top, indicated by the letters B in Figs. 1 and 3. Each rod was secured to the

top of the rotor of the variometer. This was also cut from three-ply wood with a fret-saw. The top of the rotor was an exact replica of the base of the rotor.

Fig. 4 explains how the base and top of the rotor were held in position by two vertical brass rods each 5 in. long. The same figure also shows how two spindles were fixed to the rotor, one at the top and one at the bottom. It will be clear from Fig. 4 how the wire (No. 22 enamelled) was wound on the rotor and how the ends of the winding were soldered to the spindles. These two rotor spindles, cut from threaded brass rod, were secured in position by nuts either side of the wood. The lower nut of the bottom spindle made contact with a brass contact strip screwed

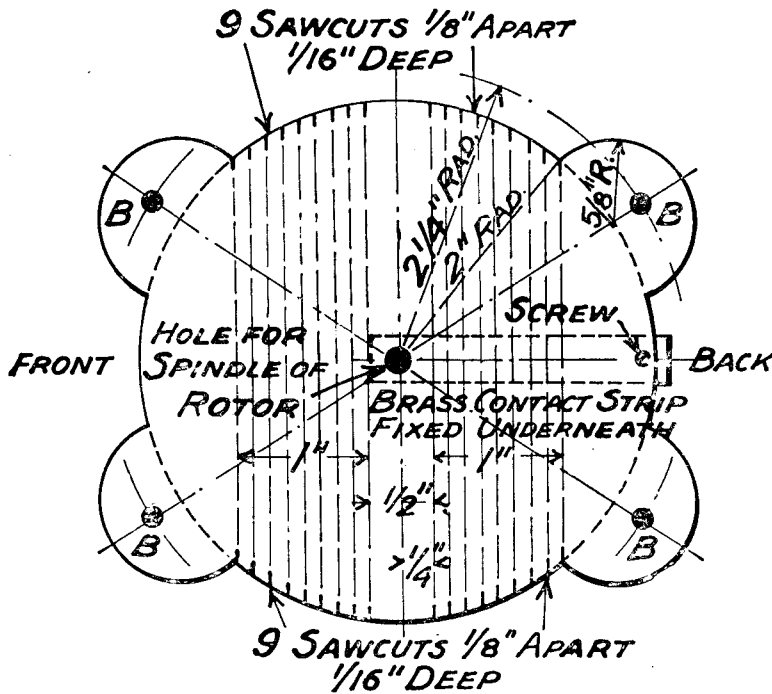

Fig. 3.—The top of the receiver is simply made.

on the upper surface of the baseboard. The position of this contact strip is indicated in Fig. 1. The top nut of the top spindle made contact with a brass contact strip mounted on the underneath of the top of the stator (see Fig. 3 for its position).

After the rotor has been wound

with its twenty turns of wire, it was placed in position with the bottom spindle on the baseboard of the instrument, and the top spindle through the hole in the top of the stator (top of instrument). The top of the instrument was then secured in its final position between the nuts at the top of the four vertical rods which had previously been mounted on the baseboard.

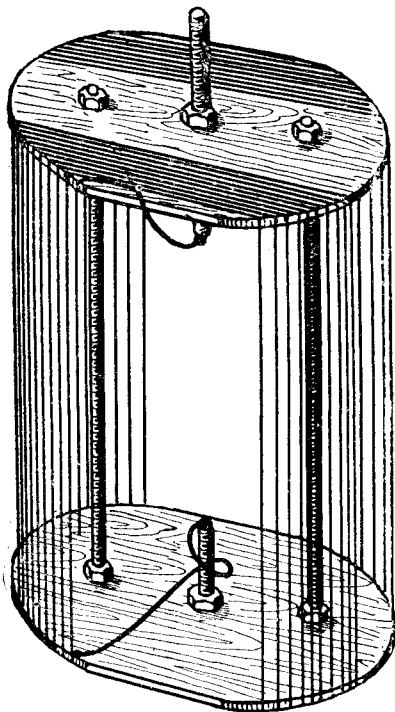

Fig. 4.—The rotor also presents no difficulties.

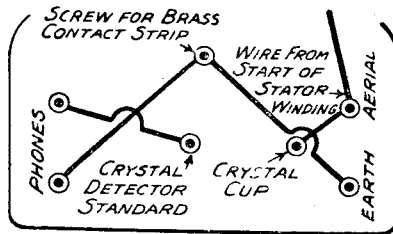

Fig. 5.—Wiring underneath base.

When the top of the instrument had been carefully adjusted to a horizontal position, the wire of the stator was wound on, commencing at the bottom left-hand side in front and winding in a counter-clockwise direction. The start of the wire on the stator was soldered to the aerial terminal, and the end of the wire on the stator to the brass contact strip on the underneath side of the top of the instrument. This contact strip made contact with the wire of the rotor and so completed the connections of the variometer.

Fig. 5 is a wiring diagram of the underneath of the baseboard. The complete wiring of the set may perhaps be understood from Fig. 6 and from Fig. 7, which is a reproduction of a photograph of the underneath of the baseboard.

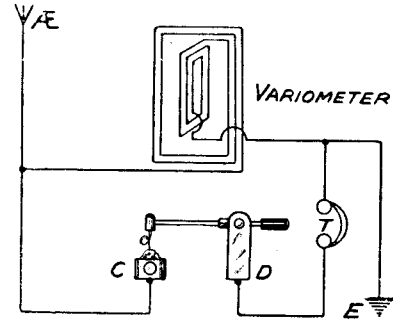

Fig. 6.—A circuit diagram of the set.

The catwhisker used in this "cage" variometer crystal set was of magnesium ribbon. With a hertzite crystal, such a catwhisker gives extremely good results. A magnesium catwhisker will also work with galena, but it does not appear to work with any other of the better-known wireless crystals.

Magnesium ribbon, familiar to every schoolboy who has worked in a science laboratory, may be purchased in rolls containing a few yards of the ribbon. Fig. 8 shows the best shape for this type of catwhisker, the end being cut to a sharp point.

Tests carried out with this crystal set have proved that its efficiency is at least that of any

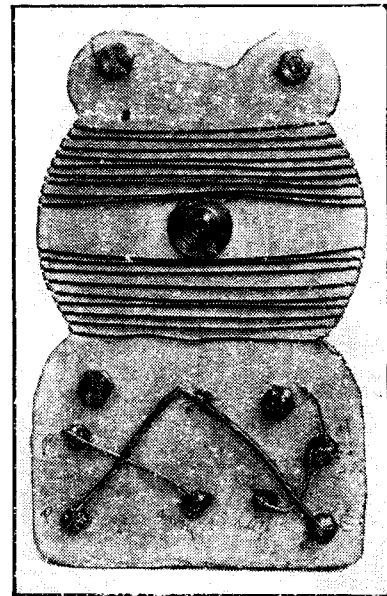

Fig. 7.—The simplicity of wiring is a great help.

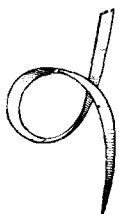

Fig. 8.—The catwhisker is novel, and consists of a piece of magnesium ribbon.

other type of crystal set. At 14 miles from D.O. telephony from that station when received on this set is all that could be desired.

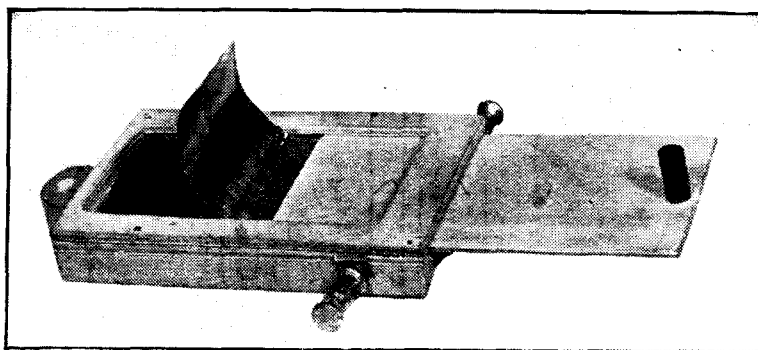

Fig. 1.—The springiness of the copper is turned to good account.

**A Cheap Variable
Condenser**

*This condenser is of novel
design and easily
constructed.*

THE necessity for a small variable condenser in the circuit when receiving within or below the broadcast band is

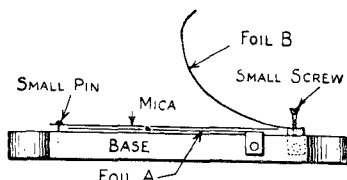
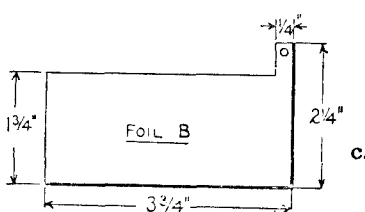
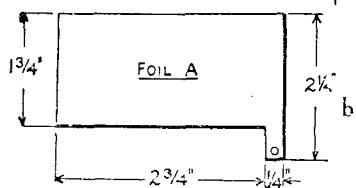
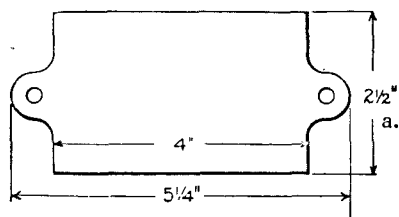

Fig. 2.—Detailed dimensions of parts.

apparent to all, especially those who like to follow amateur experimenters in the region of 200 m. The following is a description of such a condenser, which is very smooth in action and at the same time presents no difficulty in construction. The appearance of the finished article may be gathered from the photograph, Fig. 1.

Materials required :—

- 1 piece of wood, 5 1/4 in. by 2 1/2 in. by 3/8 in., for the base.
- 2 pieces of thin wood, 4 in. by 2 1/2 in. (preferably 3-ply).
- 1 piece of thin wood, 4 1/2 in. by 2 in. (preferably 3-ply).
- 1 piece of copper foil, 2 3/4 in. by 2 1/4 in. by about .006 in. thick.
- 1 piece of copper foil, 3 3/4 in. by 2 1/4 in. by about .006 in. thick.
- 2 wood screw terminals.
- 1 piece of mica, 3 1/2 in. by 2 1/2 in. by .002 in. thick.

The base plate is cut to the shape shown in Fig. 2 (a), and holes are drilled in the lugs to permit of screwing the condenser to the bench or panel. The pieces of thin wood are next cut to the shapes shown in Fig. 3 (a) and (b) respectively. This wood should preferably be 3-ply, as this type is less liable to split. These pieces may easily be cut with a fret-saw, and the edges and faces should be cleaned and smoothed up with fine sandpaper. The "shutter" may next be cut to the dimensions given in Fig. 3 (c), cleaned and smoothed, and the under edges rounded off.

Two pieces of copper foil should now be cut, as in Fig. 2 (b) and (c), and foil B should be bent round a pencil to give it a curved shape. Foil A is then laid on the base plate, far enough in from the end to allow the distance piece, Fig. 3 (a), to be laid in position on the base and to just overlap the foil on all three sides.

Lay the mica over this foil and secure the mica with a small pin.

Secure Foil B to the opposite end of the base by two small screws, so that the lugs of the foils are on opposite sides of the base. Now lay the distance piece and top cover in position, so that the open end is over the screws holding foil B down. Fix these two pieces down by means of small fretwork pins; bend over the lugs from the two foils and insert one terminal in each, making sure of good contact between the terminals and the foils.

A knob is fixed to the "shutter," as shown in Fig 3 (c), and the latter may now be inserted into the open end of the condenser. As the shutter

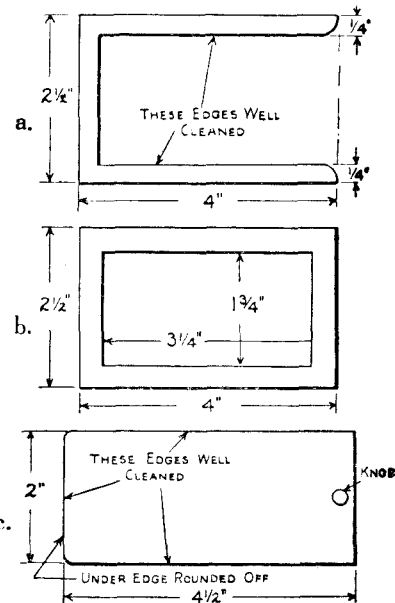

Fig. 3.—Further dimensions.

is pushed in, the top foil is forced down on to the lower one, and thus the maximum capacity is obtained when the shutter is pushed right home. The maximum capacity is about .0003 μF.



Above & below the Broadcast Wavelengths

I MUST apologise for an error which crept into two of the drawings in last month's notes under this heading. In some inexplicable way a fixed condenser became inserted in the grid circuits of the first valves of my rough sketches. I was laid up at the time when proofs came out, and so did not see them. Of course, the first things that leapt to the notice of my astonished eyes when I opened a finished copy of the paper were those two wretched condensers, but it was too late then to make any correction, for printing had been done. The circuits in Fig. 1 and 2 should *not* have grid condensers. Otherwise they are correct. I hope that no reader was put to any inconvenience, but I expect that nearly everyone spotted the obvious error and regarded it as such. It is curious how at times even the most glaring mistakes can pass the scrutiny of quite a number of experts without being detected. In one American wireless firm's catalogue which is in its fourth or fifth edition there is a "straight" circuit which shows the gridleak of the rectifier connected to high-tension positive. This same circuit has appeared in all previous editions and apparently no one has spotted the error. Yet it must have been passed in proof form by two or three experts, it must have been seen by the firm's practical man, and it must have been examined by thousands of readers, no one of whom apparently noticed it or at any rate called attention to it. Much the same thing occurs sometimes when one is making a "hook up" circuit on the bench. Either it will not work or it works badly. The circuits are checked very carefully and no error can be found. In despair one leaves it and turns to something else. On the following day one glances at it casually and is struck instantly by some ridiculous error in the wiring which defied all previous attempts at detection. We all have our moments of mad-

ness in wiring up, but so long as they do not involve the habitual connection of H.T. plus to L.T. negative or something of that kind little harm is usually done.

Components

Not everyone who goes in for short-wave reception realises the importance of obtaining components of really good quality. It cannot be insisted upon too often that the shorter the wavelength the higher is the frequency, and that when you come to really high frequencies, such as those of the order of 3,000,000 cycles per second, exactness of values is a thing that

is growing old it is desirable that the capacity of its condenser should be on the large side. Nor is it essential that the gridleaks or the anode resistances of resistance capacity coupled note amplifiers should be precisely of the value that is stated to be theirs. On the low frequency side of the set we are dealing with audio frequencies, where these things are not of enormous importance. But when we come to the radio-frequency valves and their couplings things are quite different. This applies particularly to grid condensers and gridleaks. These components must be within a very small percentage of the stated capacity, otherwise the circuits may become unstable. Cheap and badly designed gridleaks are often "all over the place" as regards their real resistances. Not long ago, suspecting the *bona fides* of one which was labelled 5 megohms, I tested it with a small megger and found that its resistance was actually something under 100,000 ohms. It is not difficult to get a resistance tested, for most practical electricians possess some kind of megger which they use for trying the insulation of household power and lighting circuits; but condensers are not so easy, for the only instrument which will measure their value properly is a capacity bridge, which is not usually seen outside laboratories. The amateur therefore is bound to rely upon the maker's guarantee. This he can do with perfect confidence in the case of well-known manufacturers, but the same implicit trust cannot be placed in the words of almost unknown firms. In the latter case the guarantee is often given in perfect good faith, but the maker has not at his disposal the apparatus necessary for proper calibration. I have had "guaranteed" condensers of cheap quality which when tested showed actual capacities ranging from .2 to 1.5 of those stated. Perhaps the most wonderful instance of what a cheap condenser

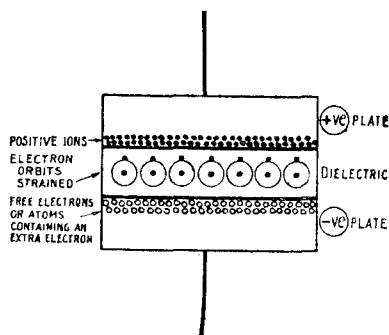

Fig. 1.—What takes place when a condenser is charged.

matters very greatly indeed. This applies, of course, to the high-frequency side and the rectifier. On the note magnifying side there are few values that are very critical. For example, it does not matter very much whether the condenser shunted across the primary of the first low-frequency transformer has a capacity of .001 μ F, .0015 μ F, or .002 μ F. So long as it is not less than .001 μ F and its insulation is good, quite efficient working will be obtained. The same is true of the telephone condenser, if one is used. The high-tension battery condenser again is not at all critical. Anything from about .3 μ F to 2 or 3 μ F will answer, though if the battery

can be occurred to a member of the staff of MODERN WIRELESS recently when he was trying one out. Various curious things happened which showed that something was amiss, and eventually the condenser was taken to pieces to see exactly what it did contain. You will gather that he was rather surprised to find that the plates had been entirely omitted in the process of manufacture, the case containing nothing but a few sheets of mica and a filling of paraffin-wax!

Condenser Efficiency

Correctness of capacity is one very important point in a condenser, and another is efficiency. It is not perhaps always realised that enormous losses, particularly where high-frequencies are concerned, may take place in a bad condenser. The whole question of efficiency turns upon the dielectric used. Now, there are three things affecting the dielectric, and in the minds of a good many people there is a certain amount of confusion between them. The first is the *specific inductive capacity*, which is often referred to as the dielectric constant of the material. We know that if we make a condenser consisting of two plates of given size separated by an air space the capacity can be worked out pretty accurately by one of the many formulæ, such as:

$$C (\mu F) = \frac{.0885 \times N \times S}{D \times 1,000,000}$$

where N = Number of dielectrics.
 S = Area of overlap of plates.
 D = Thickness of dielectric, all dimensions being in centimetres.

If for air we substituted an equal thickness of the best ruby mica the capacity of the condenser will be increased eightfold, since eight is the dielectric constant (K) of this material. The dielectric constant of air is taken as unity. This means that a more powerful inductive action takes place across mica, or, to put it in another way, the capacity of a mica dielectric condenser is greater than that of one whose dielectric is air.

The second quality of the dielectric is *strength*, which means simply its power to withstand an electrical strain without breaking down. The dielectric strength of the material is usually given as its "puncturing voltage." For example a dielectric of mica one millimetre thick will break down when a voltage of 60,000 is applied to condenser plates separated by it. The same voltage would cause a spark to pass

between air-separated plates twenty millimetres apart. The dielectric strength of mica is therefore greater than that of air; but there is one important difference between the two. If a mica condenser does break down it is beyond repair, for the dielectric is actually pierced with small holes by the passage of current. In an air condenser, however, the holes automatically seal themselves and the dielectric is self-repairing. In the wireless set we use condensers of three kinds: the variable condenser with an air dielectric, the small fixed condenser with a mica dielectric, and the large fixed condenser slanted across the high-tension battery with a dielectric usually of waxed paper. In their case the dielectric strength is well up to the work which it has to perform, and in the receiving set such a thing as a broken-down condenser is an event which occurs very rarely indeed. In the transmitting set, where very high anode voltages are used, a condenser with a waxed-

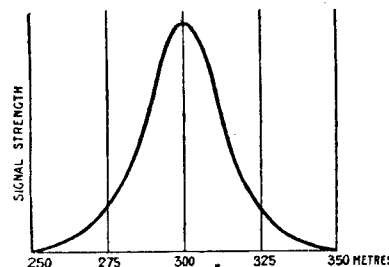

Fig. 2.—Resonance curve of a sharply-tuned station.

paper dielectric would not be good enough for the work.

The third quality of the dielectric is its *efficiency*, which has nothing to do either with its specific inductive capacity or its strength. A perfectly efficient condenser would be one which would give out exactly as much as was put into it. I say *would be* because in actual practice such a condenser cannot be made. Losses of various kinds occur in the condenser, that is to say, a waste of energy is bound to take place in it.

Losses in a Condenser

These losses may take place in a good many ways, of which only a few are sufficiently important to concern wireless men. First come those which take place by leakage over the edges of the plates. In a well-designed fixed condenser these are very small indeed, for the dielectric is made to project well between the edges of the plates. Next we have losses due to the passage of actual current through the dielectric. Fig. 1 represents

diagrammatically what takes place when a condenser is charged. Let us see what is occurring upon the opposite edges of the two plates first of all. Upon the lower edge of the positive plate positive ions, that is, atoms deficient in electrons, are crowded together; upon the upper edge of the negative plate there is a similar crowding of electrons and of atoms containing one electron more than their normal complement. The positive ions upon the upper plate and the electrons upon the lower exert an enormous mutual attraction upon one another. This attraction places the dielectric under a very great strain. In any substance there are always a certain number of atoms containing one or more rather loosely bound electrons,

Dielectric Strain

When the dielectric is under strain the orbits of these "detachable" electrons are distorted towards the positive plate owing to the pull of the electrons collected upon it. The perfect equilibrium of the atoms, though not actually broken down, is to some extent disturbed. If we continue to raise the potential applied to the condenser, a point will be reached at which it does break down; the detachable electrons will be torn from their atoms, and the latter, thus converted into positive ions, will make for the negative plate. Hence the dielectric is punctured and the whole charge of the condenser passes through it. But without actually reaching the point at which puncturing takes place the dielectric may be so strained that there is a certain passage of electrons and positive ions through it. A very small current thus passes through it, and though the condenser can hold a certain charge and can function more or less as a storer of current, very great losses will take place in it. These losses are obviously greatest in a dielectric whose detachable electrons are most numerous, and least in one where electrons are tightly bound to their atoms. In other words, the better the insulating properties of the dielectric, the smaller will be the direct losses due to leakage through it. It is obvious therefore that the better the quality of the mica or other dielectric used, the more efficient will the condenser be. Mica is a substance which varies very much indeed in quality. Poor stuff has comparatively small insulating properties and leads to large dielectric losses. It is essential therefore that for high-frequency work where the impulses brought in by the aerial have only

the most minute energy thoroughly efficient condensers should be used, for we cannot afford to lose any big proportion of the small amount of energy that is available.

The third source of losses comes from what is known as the "soaking in" effect. This means that if a condenser is charged up and then discharged it does not give up the whole of the stored current. If left for a while it will be found that its plates are again charged, though to a very much smaller extent. What appears to happen is that where the electron orbits of the dielectric are very much strained when the condenser is under charge, some of its electrons though not actually passing on to the positive plate, yet exert such an attraction upon the positive ions in it that a certain number of them remain as it were bound even when discharge takes place. A certain small charge is therefore left. If charging up and discharging are done very slowly the effects of "soaking in" will not be apparent; but when the condenser is dealing with millions of cycles a second, as it must do when it is used for short-wave work, "soaking in" may give rise to quite serious losses. Soaking in, again, is a question of dielectric quality, and provides yet another reason for using only the best fixed condensers for high-frequency work when short-wave reception is attempted.

The efficiency of a dielectric is measured by the ratio between output and the input of a condenser made with it. Air is the most efficient of all, though really good ruby mica may reach 90 per cent. of its efficiency. With poor quality mica the efficiency may be as low as fifty per cent. or even less. Glass, ebonite, waxed paper and other dielectrics are all very greatly inferior to the best mica in point of efficiency.

Overcrowding

Overcrowding upon all wavelengths is becoming more and more a serious problem, as every experimenter knows to his cost. The trouble is not so much due to the number of actual transmissions that take place as to the fact that most of them appropriate not one wavelength but several. Spark signals are, of course, the worst offenders, for no way has yet been devised for obtaining a perfectly sharply-tuned transmission by means of the ordinary gap with which so many ship and shore stations are fitted. If a spark transmitter is very loosely coupled it will transmit a wave which has a distinct peak, as shown in Fig. 2.

Thus a transmitter tuned to 300 metres and loosely coupled would be barely audible, unless it was very powerful, on either 250 or 350 metres, and would not be sufficient to interfere with other spark signals of equal strength on 275 and 325 metres. Still it would cover a fairly large band, say from 285 to 315 metres, or 30 metres in all.

If tight coupling is used matters become very much worse, for in place of one peak we now have two with no very great drop between them, as seen in Fig. 3. A transmitter tuned in this way may send out signals which have almost the same strength over a very wide band and will cause an enormous amount of interference. There is a Board of Trade regulation governing the percentage of coupling that may be used, but to judge from the flat tuning of some of the 300-metre and 600-metre signals it is frequently honoured more in the

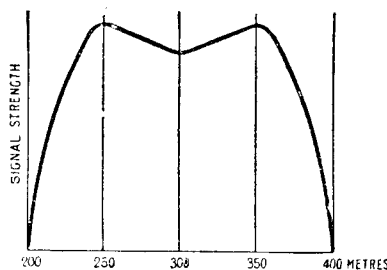

Fig. 3.—The effect of tight coupling.

breach than in the observance. Spark signals, luckily, are not much given to the production of powerful harmonics, though Mr. Harris tells me that he has on several occasions picked up Ushant's harmonic on the shorter wavelengths. With the coming of C.W. telegraphy it was hoped that the great drawback of the spark system would be done away with, for here very sharp tuning is possible. But it is another instance of the old saying about the swings and the roundabouts, for some of the big C.W. stations, if they do not bother us with flat tuning, drive us to distraction with their harmonics. The question of harmonics is a really interesting one which does not seem to have received sufficient attention. You will find it laid down in the older text books that harmonics in wireless can occur only on one-third, one-fifth, one-seventh and so on of the fundamental wavelength, but actual experience does not bear this out with C.W. or telephonic transmissions. 2LO, for example, can be tuned in upon one-half, one-third or one-quarter of his wavelength, and the Paris station of

Ecole Superieure des Postes et Telegraphes, which transmits upon 450 metres, can usually be tuned in with considerable strength upon 225. The recognisèd system of calibrating home-made heterodyne wavemeters depends entirely upon the use of harmonics. The method is as follows. Tune the set to any station of known wavelength and take a reading on the wavelength. Now leave the receiver alone and turn the wavemeter back until the first harmonic is detected; this will occur on exactly half the original wavelength. Suppose we select a station with a wavelength of 3,000 metres, we shall obtain harmonics on 1,500 metres, 1,000 metres, 750 metres, 600 metres, and so on. The tenth harmonic is usually the last that can be detected, and it takes very careful listening to do this. In the same way overtones will be heard upon 6,000 metres, 9,000 metres, 12,000 metres, and so on. These harmonics occur in the heterodyne wavemeter and the receiver itself, and are not due to the transmission.

Harmonics

C.W. harmonics are responsible for a very great deal of the interference upon short wavelengths with which one is bothered, and it is very largely due to the prevalence of harmonics and overtones that the "overcrowding of the ether" of which we read so often is becoming more and more marked.

Luckily, harmonics are not always very powerful; they may, in fact, be almost inaudible at a reasonable distance from the transmitting station. The problem is very largely one of the design of the transmitting gear itself and of the aerial. It is for this reason that some stations are so very much worse than others as regards the mush and hash that they broadcast, to the despair of listeners upon certain wavelengths.

CORRECTIONS.

It is regretted that the following corrections are necessary in the article on the Three-Valve Dual Receiver in the last issue:—

- (1) In Fig. 7, T₃ and T₄ should be reversed.
- (2) In the list of connections, 22-25 should read 22-T₅.
- (3) On page 572, fifth line, for "and T₉ to T₁₀" read "and T₈ to T₁₀".

These corrections, of course, do not affect the circuit or wiring diagrams, which give a correct guide to the connections of the set.

In the article upon an S.T.100 Star Receiver, the terminal marked "H.T.+" in Fig. 7 should be marked "H.T. +."



SOONER or later every owner of a wireless set is seized with a desire to listen for the more distant broadcasting stations—not that their programmes are better than he is in the habit of hearing from his near-by broadcasting centre—but simply because he feels it is some achievement to get them.

The Kind of Set You Need

Unfortunately there are so many variable factors in wireless that one cannot predict for certainty that anyone can receive all of the stations on any set. Provided, however, that you possess a reasonable aerial properly insulated, the following should be the capabilities of the various sets named.

(1) *Crystal Set.* A well-designed crystal set will give excellent telephonic signals at 10 miles, fair to medium headpiece signals up to 20 miles, while speech and music can be heard (though not with any comfort to the man who desires to listen to the station for the amusement the programmes provide) up to 30 or even 40 miles when conditions are favourable. This last phrase "conditions are favourable" has much more in it than might occur at first glance. For example, some places are badly screened, others are known as "dead spots." We cannot take a map and describe a circle around a broadcasting station at, say, 20 miles and state at the same time that signals from this station will be received at equal strength on all parts of the circumference. A line joining points of equal strength will never be a circle and will sometimes be a greatly distorted figure. Only on very rare occasions when conditions are particularly favourable will it be possible to hear a second or third broadcasting station on a crystal set, although at times these have been received.

(2) *Single-Valve Sets with Reaction.* A single-valve set with reaction will give excellent telephonic signals from two broad-

casting stations, and with very careful adjustment and a critical setting of the reaction (in such a way that in inexperienced hands there is almost bound to be trouble from oscillation) it will be possible when conditions are favourable to receive all of the broadcasting stations. The fact, however, that your friend has succeeded in receiving them all is no indication that you will be able to do so, nor can I advise you to endeavour unless you are thoroughly experienced. The addition of note-magnifying valves to single-valve circuits with reaction will increase the volume of signals, but will not appreciably increase the *distance* from which the signals can be received.

(3) *2 Valve Set consisting of one High-Frequency Valve and a Detector.* A well-designed set with one high-frequency valve and a detector, using reaction with reasonable aerial, should enable you to hear all of the broadcasting stations on most evenings. The setting, however, will need to be carefully made, and the volume of sound from the distant stations will not be at all great. The addition of one stage of note magnification will give you a good all-round set which will bring in all of the broadcasting stations at reasonable strength and usually two at least at loud-speaker strength.

(4) *3-Valve Set consisting of Two Stages of High-Frequency and a Detector.* A set with two well-designed high-frequency stages followed by a detector should enable you to receive all the British broadcasting stations and most of the Continental with ease and without the need of pressing reaction to the last limit with its accompanying distortion. Such a set will frequently give all of the stations on a small frame aerial two or three feet in diameter. Stages of note magnification added to such a set will give great volume, and usually one stage of note magnification

added to such a set, making four valves in all, will operate a loud-speaker from all the British and most of the Continental broadcasting stations.

Procedure in Tuning

Most people pick up the distant broadcasting stations by tightening the reaction coupling until the set just oscillates, and then varying the tuning condensers until they hear the high-pitched note of the beat signal set up by their own oscillation and the carrier wave of the broadcasting station. Further adjustment of the tuning condensers will reduce the tone of this note from a high-pitched squeak down to zero point, after which further turning will raise the note again, when once more it will reach a high-pitched squeal. On the neutral point best results will be obtained, and if the reaction is slacked off the telephony is heard properly. The disadvantage of this method is that it will cause interference to any neighbouring listeners who are trying to obtain signals on the same wavelength, and, save in cases where the set can be made to oscillate without the energy getting to the aerial, is not to be recommended. After you have become used to your set you will gather when the set is fairly near to the oscillating point, and then by careful turning of your tuning condenser dial you should be able to pick up the other stations without oscillating.

The Ideal Way

The ideal way is, of course, to use a properly calibrated wavemeter. It is then only necessary to set the wavemeter scale at the wavelength of the station you desire to receive, whereupon it will emit a buzzer note which you will hear in the phones loudest when your set is tuned to that wavelength. On stopping the buzz and carefully listening, and with further slight adjustment of reaction, you should hear the distant stations.

Wireless in the School

By E. H. CHAPMAN, M A., D.Sc. (Staff Editor).

The regular broadcasting of lectures to schools is now an accomplished fact. In this article Dr. Chapman, who has great experience in scholastic matters, shows how the best can be made of these lectures.

JUDGING from the success which is attending the broadcasting of a series of educational lectures from the London broadcasting station to schools during school hours, it would appear that a wireless receiving set will become a necessary part of the equipment of the majority of our schools in the near future.

more. In this country the efforts of the Glasgow and London broadcasting stations can but be the beginnings of great developments in the use of wireless as an educative medium.

The wireless experimenter is familiar with the problems which arise in connection with the design and assembly of receiving ap-

loud-speaker reception of far greater strength than is usually the case.

The School Aerial.

Since the very best signal strength must be obtained from the wireless receiving apparatus installed in a school, it is of the utmost importance that a school aerial should be of maximum efficiency. Fortunately, there is often plenty of room round about a school, and at most schools it will be found possible to erect not only a high aerial, but one which is clear of all school and other buildings.

Five years ago the writer assisted in the erection of a school aerial on the Lancashire coast. The twin-wire aerial was slung between

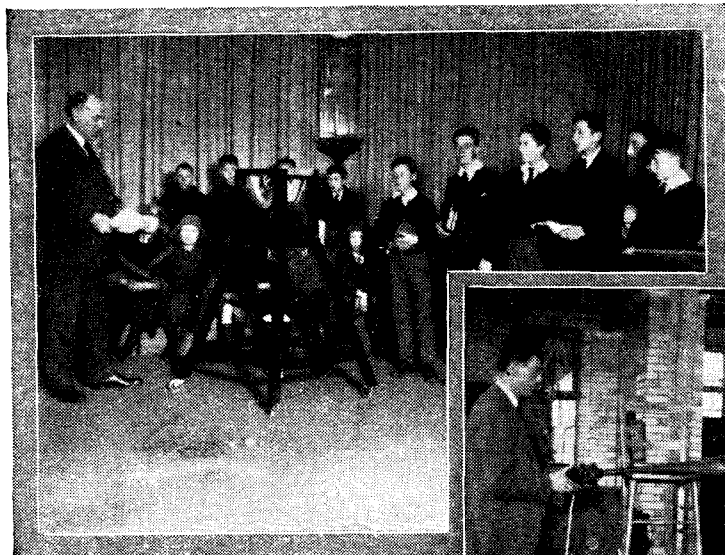

Dr. Walford Davies and the choir boys from the Chapel Royal, Savoy, broadcasting from 2LO.

London, of course, does not stand alone in having achieved success in this pioneer broadcasting work. Glasgow had previously placed to its credit a similar successful series of educational talks to its schools. On the other side of the Atlantic, where we have become accustomed to look for comparisons, broadcasting has repeatedly been used as an aid to educational progress, and the latest proposal there is the establishment of a wireless university made up of a chain of colleges, each one of which is to be equipped with transmitting apparatus. Eventually, it is hoped, this chain of colleges will reach from the Atlantic to the Pacific coast and will cater for the higher educational needs of a hundred thousand students or



How the lessons were received in a school.

paratus for schools. A school, however, has to look at these problems from a somewhat unusual angle. Whereas the wireless experimenter at the most has to cater for, say, half a dozen listeners-in, a school may find it necessary to provide for several hundreds. Hence, in designing and assembling a wireless receiving set for a school, provision must be made not only for the usual reception in telephone receivers but also for

a couple of chimney-stacks at a height of about 10 ft. above the ridge of a roof. Certainly that aerial was efficient as far as receiving the Eiffel Tower and Air Ministry Morse signals was concerned. The school referred to stood in its own grounds of over forty acres, and subsequent experience has shown how much better it would have been to have erected that aerial so that the greater portion of the horizontal

wire would have been out in the open and not over any part of the school buildings.

In the grounds of many of our schools there is a flagstaff situated some distance away from the school buildings. One of the easiest methods of putting up an aerial is to run the wire from the top of such a flagstaff to as high a point as possible on the school building.

A single-wire aerial recently erected in this way by the writer has proved of marked efficiency. On a well-known type of three-valve set loud-speaker telephony from 2 L.O. 15 miles away, was obtained of sufficient strength to be easily audible over a small school hall in which there were over a hundred and fifty boys. The flagstaff used had just been presented to the school, and before it was erected a second pulley and hoisting

of greater length than is possible in a house.

The writer has recently suggested to the wireless club of a neighbouring school that experiments might be made with an aerial slung from one chimney to another at the school in such a way that the whole aerial will be suspended above a large, flat, lead-covered roof. This roof is a good 70 ft. long, and the aerial can be fixed 15 ft. above it, the idea being that the lead-covered roof would make an excellent counterpoise.

The School Set

With regard to the choice of a school set, it is only possible to be emphatic over one thing, and that is that every school should construct its own receiving set or sets. Recently a prominent educational journal gave the cost of a suitable wireless receiving

anything like an order of merit according to their fitness for use in schools. Each particular set has been designed to fulfil certain requirements, and each set possesses its own individual and distinct features. What should appeal specially to schools, is that in MODERN WIRELESS and *Wireless Weekly* the established practice is to test every set described very thoroughly under standard conditions and to state exactly what the set will do. The writer has had actual experience in schools with the S.T.100 receiver, invented by the Editor of MODERN WIRELESS and *Wireless Weekly*. He has also had similar experience with the 3-valve Reinartz receiver, designed by Mr. P. W. Harris. These are but two of the many Radio Press receivers which will undoubtedly be all that a school will require.

The Wireless Lesson

In making use of lessons by wireless, the educational authorities, in conjunction with the broadcasting authorities, are confronted with several new problems. The first is the creation of the right atmosphere in the many classrooms containing classes who are listening-in. This problem has, at any rate, been partially solved by providing the speaker with a class in the broadcast studio and causing him to give his lecture or lesson to this class rather than to the microphone. The logical sequence to this ingenious idea is to carry the microphone into a real classroom and transmit all that goes on in that classroom. There are teachers of outstanding merit in every subject taught in our schools, and a lesson from any one of these teachers under actual working conditions would be well worth broadcasting to other schools.

Another problem with regard to the wireless lesson is that of bringing the wireless teacher into contact with the taught. This can possibly be solved by adopting the method of broadcasting answers to correspondents, as is done during the present children's hour at our broadcasting stations.

The "wireless lesson" has come to stay, and whatever success it may win in the future, it may claim to have achieved one great initial success in that it has caused the Minister of Education and members of one of the foremost education authorities in the country to go back to school and sit quietly through the whole of a lesson once again.



An efficient school aerial.

cord were fitted to it to take the wireless aerial without interfering in any way with the main purpose of the flagstaff. A large insulator carrying the free end of the aerial wire was attached to the cord and hoisted to the top of the flagstaff. The insulator at the other end of the horizontal portion of the aerial wire was secured by a short length of stout cord to a hook driven in the outside of the frame of the highest window on that side of the school. The downlead of the aerial came down about five feet from the side of the building and entered the school by a window on the ground floor.

Apart from the actual reception of broadcast educational talks, a school is an excellent place at which to make a series of experiments in wireless reception. Usually it is possible to erect different types of aerial and to compare the results they give. Indoor aerials can easily be erected in a school, and they can be made

set for a school as being anything from £40 to £100. Not only will a school by making its own wireless set reduce these figures by at least 75 per cent., but it will provide a most interesting and educative piece of work for its pupils to carry out.

Every school possesses boys who are really gifted in constructional handwork, such as is required in the making of a wireless set. In MODERN WIRELESS, Vol. 1, No. 6 (page 413), a description was given of a somewhat novel type of variometer-tuned crystal receiver. This particular type of crystal set proved very popular amongst schoolboys, and practically every set the writer has seen made by a schoolboy has possessed some neat feature in construction.

MODERN WIRELESS and *Wireless Weekly* have been full of descriptions of receiving sets which should appeal to schools in no uncertain manner. It would be obviously impossible to place those sets in

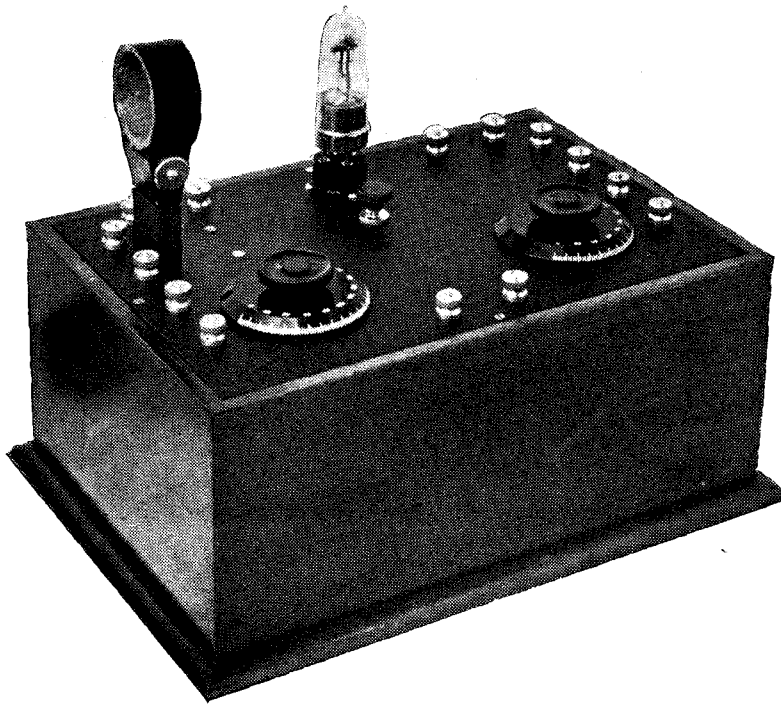

Fig. 1.—This double purpose unit shou'd prove very popular.

The "M.W." Single-Valve Dual Unit

How To Improve Your Crystal Set

For those who desire to add a valve to their crystal receiver, the unit described below will prove of considerable interest.

THESE must be a considerable number of users of crystal receivers who have at some time considered the addition of a valve to their set, and have at once wondered what is the best way to effect the change. A number of single-valve amplifying units have been described in the technical journals, but for the more ambitious constructor these do not seem to entirely fill the need, as they usually take the form of a note magnifier.

The unit to be described is designed to convert a simple crystal set into a valve and crystal dual amplification receiver, while the original crystal set is left exactly as it is, with one reservation. The only point which must be impressed upon the reader is that if the crystal set employs a condenser in series with the tuning coil, this condenser must be short-circuited; the reason for this will become apparent when the circuit arrangement is discussed.

The complete unit, a photograph of which is given in Fig. 1, is of quite handy size and neat appearance. The left-hand dial controls the aerial tuning condenser, while the anode tuning condenser is seen on the right. In the centre of the panel, at the back, is the valve-holder, with the filament control in front of it. This control is a Lissenstat minor, which is equally suitable for bright or dull emitter

valves; thus either type may be used at will without change to the existing set. To the left of the valve-holder are seen two terminals, which are connected to the primary winding of the low-frequency intervalve transformer. The two terminals on the right of the valve-holder are those to which the "aerial" and "earth" terminals of the crystal set are connected, the telephone terminals of the latter being connected to the two terminals of the transformer, previously mentioned.

The terminals on the right are for the high- and low-tension batteries, while those on the left are the aerial circuit terminals.

Circuit Diagram

The circuit arrangement is seen in Fig. 3. C.A. is a fixed condenser of 0.0001 μ F. capacity, by means of which the constant aerial tuning system may be applied. The aerial lead is connected to terminal A if it is desired to use this form of tuning, while the ordinary aerial-to-grid method is

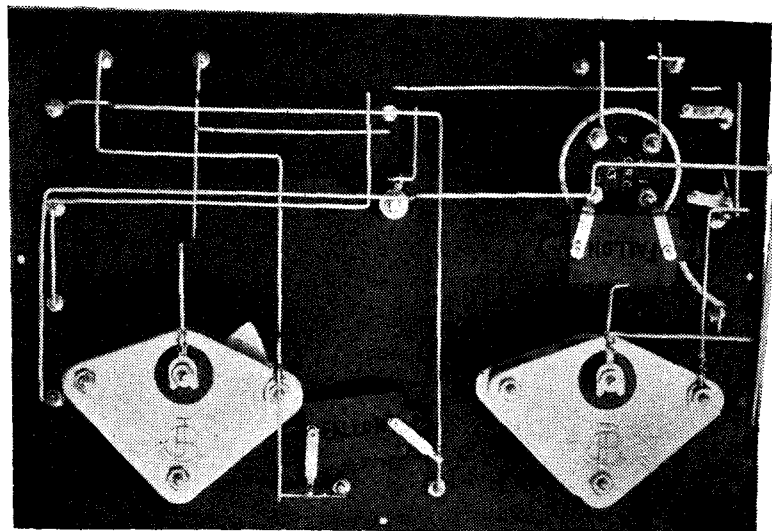

Fig. 2.—Behind the panel the wiring is exceedingly simple.

obtained by joining the aerial to terminal A₁. E is the terminal to which the earth lead is connected. The aerial coil is connected between A₁ and B.

In the anode circuit of the valve are seen two terminals, marked "crystal set," these terminals being shunted by a variable condenser. These are connected, as shown in Fig. 4, to the aerial and earth terminals of the crystal set. It is clear that if a series condenser existed in the crystal set, the high-tension supply to the anode of the valve would be entirely cut off. Hence it is essential to short-circuit such a condenser, if one is incorporated in the crystal set.

Thus the valve acts first as a high-frequency amplifier, the coil in the crystal set being the anode tuning inductance. The amplified high-frequency currents are rectified by the crystal, and the rectified currents are then fed back through the low-frequency transformer to the valve, which now acts as a note magnifier.

Components.

The set is very simple in design and construction, and very few components are necessary. Those used should be of good quality, in order that the best results may be obtained. A list of the necessary parts and their cost is given, and will form a useful guide to the constructor when purchasing the necessary parts.

COMPONENT.	s.	d.
Cabinet (Wright & Palmer)	12	6
Panel, 12 in. x 8 in. x 1/4 in.	4	0
2 0.0005 Jackson Condensers, Super type	16	0
1 Valve-holder (Goswell Eng. Co.)	1	6
14 Terminals	1	9
1 L.F. Transformer (General Radio Co.)	15	0
1 Lissenstat Minor	3	6
Fixed Condensers: One 0.0001 μF.	2	6
One 0.001 μF.	3	0
One 0.002 μF.	3	0
Total	£3	2 9

The ebonite panel should have its glossy surface removed by rubbing

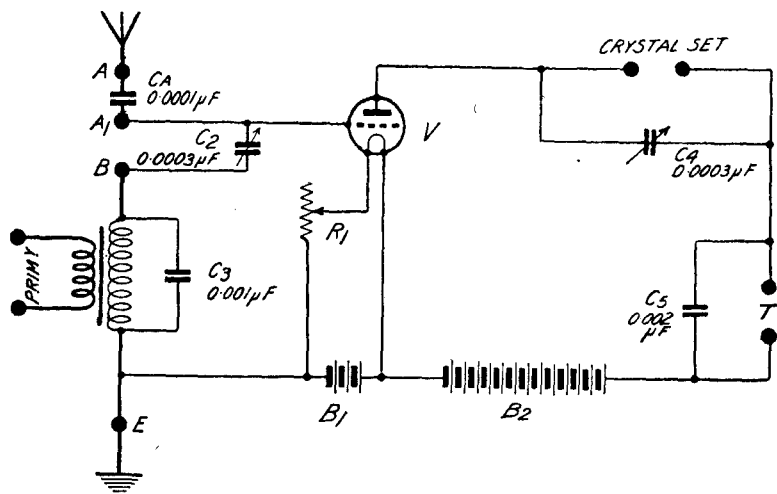

Fig. 3.—The circuit of the unit. The aerial coil is joined to A₁ and B.

with fine emery-cloth, as this improves the insulation and renders the set more free from undesirable noises, which are caused by the poor insulating quality of the glossy skin. A half-size drilling diagram is given in Fig. 5, and will make the drilling of the panel an easy matter. It is easy to mark out the panel by measuring off the diagram with a pair of dividers, doubling this measurement and setting out on the panel. The holes are next to be drilled, and in this connection it is advised that all holes of one size should be drilled straight off, afterwards changing the drill and proceeding with the next size holes. This saves considerable time and is much easier than drilling each hole in turn, irrespective of size.

Mounting the Parts.

When all holes have been drilled the component parts may be mounted on the panel. The Goswell valve-holder is of a particularly good design, as it obviates the necessity for accurate drilling of holes for

the valve legs. The usual four holes are drilled, and a larger hole in the centre of them allows a screw to go through the panel, by means of which the valve-holder is secured in position; the necessary leads to the sockets are pushed through the correct holes in the panel, and fastened by means of the screws on the valve-holder.

When all parts are mounted up and firmly secured in position, we may turn to the wiring up of the set. This is an extremely simple operation, and should present no difficulty even to the beginner.

The simplest way of wiring up a set is to follow some definite order, and thus a system has been evolved and used in sets described in *Wireless Weekly* by means of which wiring is made an exceedingly simple task. The method consists of giving a number to each point, such as a terminal, condenser lug, and so on, to which a wire has to be joined, and then following this up by a table of connections. By joining up the points in the order named a neat job can be made of the set, and with the added advantage that mistakes can easily be detected.

Numbers Allotted Components.

- Aerial circuit terminals, A, 1; A₁, 2; B, 3; E, 4.
- Aerial tuning condenser, 5, 6.
- Aerial tuning coil, 7, 8.
- 0.0001 const. aerial condenser, 9, 10.
- L.F. transformer, P₁ = I.P. = 11. P₂ = O.P. = 12. S₁ = O.S. = 13. S₂ = I.S. = 14.
- Primary terminals on panel, 15, 16.
- Transformer bypass condenser, 17, 18.
- Filament resistance, 19, 20.
- Valve, P, 21; G, 22; Filaments, 23, 24.

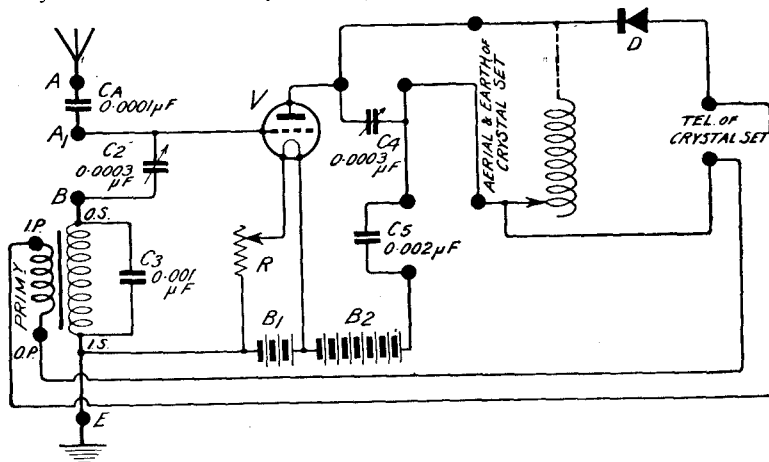

Fig. 4.—How the crystal set is joined up. Phones originally used on crystal set are joined across C₅.

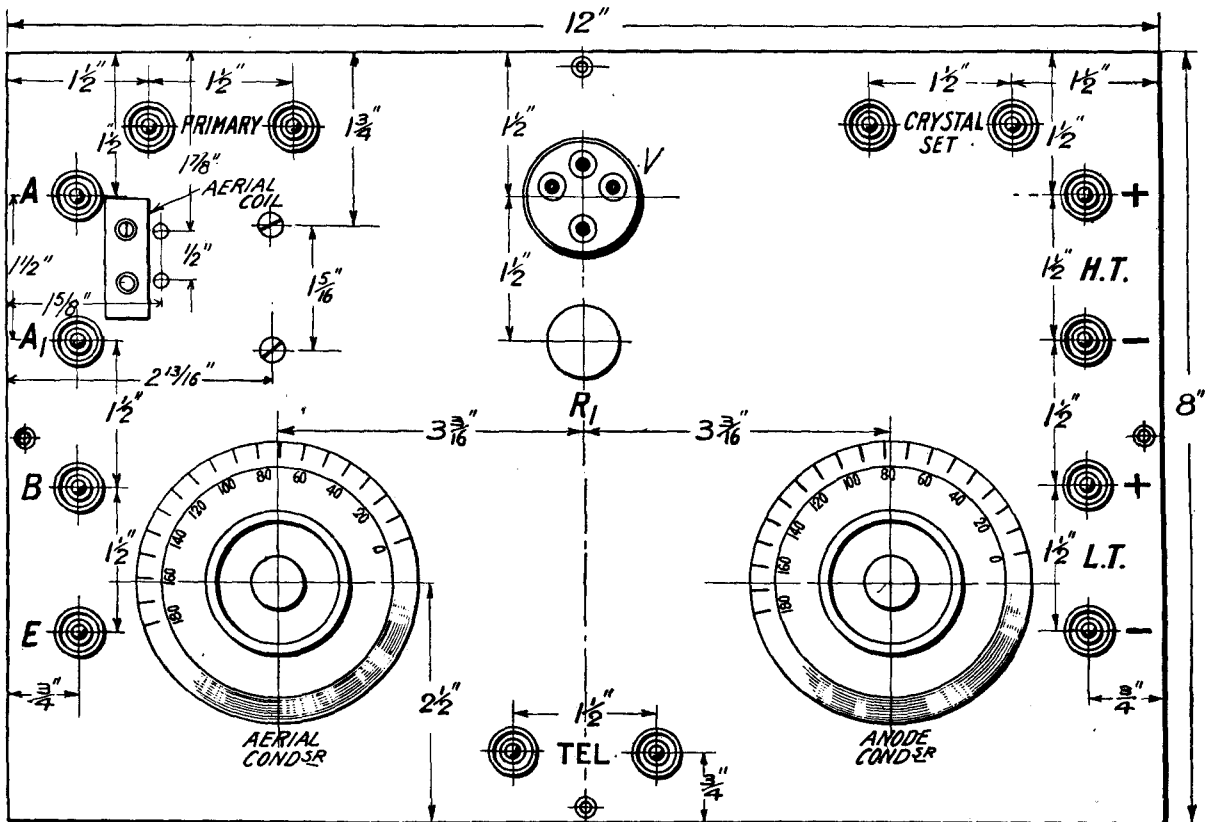

Fig. 5.—A half-size drilling diagram of the panel top. Left and right hand "crystal set" terminals go to aerial and earth terminals of crystal receiver respectively.

Terminals marked "crystal," 25, 26.
 Anode tuning condenser, 27, 28.
 Telephone terminals, 29, 30.
 Telephone condenser, 31, 32.
 H.T. +, 33 ; H.T.—, 34 ; L.T. +, 35 ; L.T.—, 36.
 POINTS TO BE JOINED.

(2-8), (3-7), (1-9), (2-10), (2-5), (2-22), (19-23), (11-15), (12-16), (21-25-28), (26-27-30-32), (29-31-33), (3-6-13-18), (24-34-35), (4-14-17-20-36).

The lugs of the fixed condensers may, in some cases, be soldered directly across terminals, thus saving complication of wiring. This is only possible in cases where the lugs of the condensers are the same distance apart as the terminals across which they have to be connected. If the wiring key above is followed, it will be found that the wires build up from the panel outwards; thus when one wire is put in place it does not have to be disturbed in order to make others fit.

Wiring may be carried out either in stiff tinned-copper wire of round or square section, or in a thinner wire, covered with systoflex tubing. This latter method is by far the simplest, and will, no doubt, appeal to the novice; but stiff wire looks much neater when carefully done, and capacity between the wires is

reduced to a minimum by spacing the wires as far as possible, and also because they are separated only by air.

The wiring is easily followed from the wiring diagram, Fig. 6, and no difficulty should be experienced in this operation. A point which must be mentioned in this connection is that if the constructor uses any transformer other than the G.R.C. type used in this set, he will not find the ends of the windings marked in the same way. The G.R.C. transformer is marked P₁ and P₂, and S₁ and S₂, the P indicating the primary and S the secondary windings. When using another make of transformer, which is marked in the more usual way, the following will apply:—

- P₁ = I.P.
- P₂ = O.P.
- S₁ = O.S.
- S₂ = I.S.

The Cabinet

The containing box is exceedingly simple to make, being of the square pattern, the panel resting flat in the box, flush with the surface. The inside measurements of the box are thus 12 in. by 8 in., while the depth must be sufficient to accommodate the largest component used. In this case the box is 5 1/4 in. deep inside. To make the box the

following pieces of wood will be required:—

- Two 12 3/4 in. x 5 1/4 in. x 3/8 in. for the sides.
- Two 8 in. x 5 1/4 in. x 3/8 in. for the ends.
- One 13 3/4 in. x 9 5/8 in. x 3/8 in. for the base.

These are smoothed up, and secured together by means of small brads, the two sides overlapping the ends, not vice versa. When this has been done and the base fastened on, a ledge is formed from 3/8 in. x 1/2 in. strip wood at a depth of 1/4 in. from the top. The panel being 1/4 in. thick, it will rest flush with the top of the box when secured in position. The panel is secured in the box by four wood screws, one in the centre of each side, which pass through the panel into the ledge beneath.

Using the Unit

When complete the dual unit may be connected up to an existing crystal set and tested. Using the constant aerial tuning system, connect the aerial to terminal A and the earth to E. A No. 50 coil should be used in the aerial socket when using constant aerial tuning and when the station whose signals are required are below 420 metres. Above this wavelength a No. 75 may be used, although a No. 50 will cover the whole range of wave-

lengths. The anode tuning coil is, of course, the coil in the crystal set, and this coil will determine the maximum wavelength to which the set will tune. The addition of a loading coil to this set will, of course, increase the wavelength, and will form a useful way of obtaining greater range of wavelengths. A plug-in coil will be the most useful way of adding a loading coil, while the socket into which this coil is plugged can be shorted when the lower wavelengths are to be received. Any good make of valve may be used, and a dull emitter will be found satisfactory, the filament resistance used being suitable for either type of valve.

Connect up the batteries and telephones to the correct terminals, and join the terminals marked "crystal" to the aerial and earth terminals of the crystal set. The telephone terminals of the crystal set are connected to the terminals marked "Primary." Using the coils mentioned above, with the aerial and earth connected, turn on the filament, having made sure that the cat-whisker touches the crystal. Turn the condensers over their scales, and the local station should be heard very easily. The more

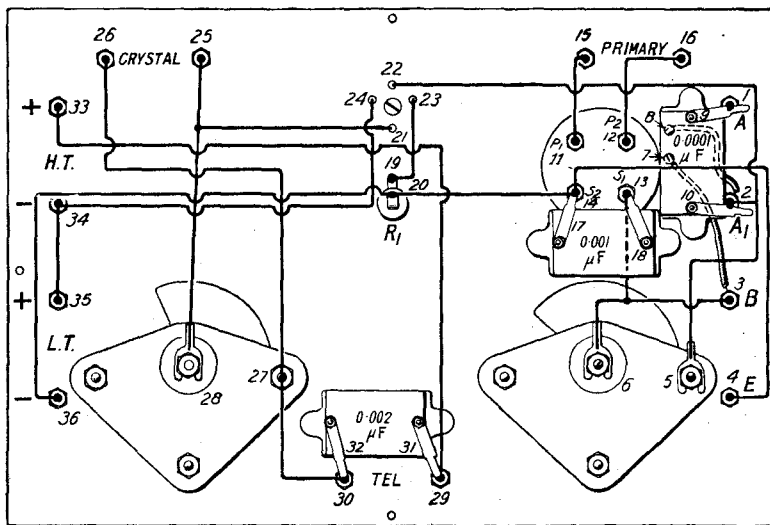

Fig. 6.—Practical wiring guide.

distant stations should be tuned in with a little care and practice. If constant aerial tuning is not required, the aerial is connected to terminal A₁, leaving the other connections as before.

The unit forms an efficient way of adding a valve to a crystal set, and should appeal to all who desire to get beyond the elementary stage.

Blue print No. 35A is the front of the panel, with all dimensions, while the back-of-panel wiring is given in No. 35B. Each 1s. 6d., post free.

What You May Have Missed.

THOSE readers of MODERN WIRELESS who may not be regular readers of *Wireless Weekly* will have missed many good features which have appeared during the last month in the weekly companion produced by the same staff as MODERN WIRELESS.

You have, for example, perhaps missed the first technical description of the microphone, invented by Captain Round, and used at 2LO. This microphone is of fascinating design, and facilities were given by the B.B.C. for full inspection of its mechanism and operation.

Another very highly interesting article which has appeared during the last month is one dealing with the strength of signals around a broadcasting station. Photographs and maps, on which were drawn contour lines showing the strength of signals at different distances from the broadcasting station were given, and the surprising effect of buildings, hills and water were shown in a remarkably clear and original manner. No article of its kind has ever yet appeared, and the aerial photograph of a broadcasting station and the sur-

rounding city is a valuable contribution to radio journalism.

Still another principal feature was the new Armstrong super-heterodyne circuit. This circuit, which is the most recent introduced by Major Armstrong, combines dual amplification with super-heterodyning, and full details of the operation of the circuit were given in *Wireless Weekly*.

All these features were exclusive to *Wireless Weekly*, and no details have been given elsewhere.

In another issue during the month full information was given about the super-pliodyne circuit emanating from America, and this circuit was discussed from a critical standpoint.

As regards constructional articles, *Wireless Weekly* has specialised in one main constructional article every other week. Each of these sets has been tested by John Scott-Taggart, F.Inst.P., A.M.I.E.E. Editor of *Wireless Weekly*, and a personal and critical test report is published in each case. The most notable set published during the month dealt with a three-valve set on which all the B.B.C. stations were received on a loud-speaker. This is probably the most effective set described in *Wireless Weekly*.

A new design of ST.100 set has also been published, and particulars given of an economical broadcast

receiver and heterodyne wave-meter using one valve. A series on an experimenter's unit receiver and another series dealing with valve transmission and telephony have appeared, and every week the usual "Valve Notes," a unique weekly feature written by the Editor, has appeared.

On April 2 was published the circuit diagram and full particulars of His Majesty's wireless receiver, this again being the first published description.

In addition, a simple and selective two-valve circuit was described by A. D. Cowper, M.Sc., whose regular contributions form a special feature of this paper.

Every other week the Omni receiver is discussed and circuits and experiments given.

It is impossible to give more than a fraction of the contents of the issues published during the last month, but some indication will be given of the unique nature of the articles. The fact that within the last month or two the circulation has increased by 7,000 copies per week is some indication of the growing popularity of *Wireless Weekly*. Any reader of MODERN WIRELESS who would like to "try" *Wireless Weekly* should give an order to his newsagent to supply until the order is countermanded.



The Finishing Touch

TO YOUR RECEIVER

is provided by

MARCONI VALVES

MADE AT THE OSRAM LAMP WORKS

Which have set the standard by which others are judged. The choice of valves is most important and it is essential that YOU SHOULD AVOID Foreign substitutes which are offered as being "Just as Good."

We are exhibiting at the **BRITISH EMPIRE EXHIBITION, - - WEMBLEY, 1924.** Electrical and Allied Engineering Section. **STANDS—** Avenues 11-13 Bays - 11-15

Remember: each replacement costs you at least 12/6, therefore be sure of the best results during the longest useful life by insisting on used in the world's largest **MARCONI VALVES** which are wireless stations.

NOTE.—The Osram Factories were, nearly four years ago, producing "Dull Emitter" Valves; the experience thus gained is at your service.

R. Type	12/6
D.E.R. "	21/-
D.E.3. "	30/-

Prices and specifications of other types on request.

SOLD BY ALL LEADING WIRELESS DEALERS, ELECTRICAL CONTRACTORS, STORES, ETC.

BUY BRITISH GOODS ONLY

Brandes

The Name to Know in Radio.



*Result of
15 years'
experience*

Brandes and the Woman.

PRICE
25/-

*British manu-
facture (B.B.C.
Stamped) and
conform to all
new licensing
regulations*

Mere man feels a bewildered impunity at the bargain counter—his Eve descries value with unfailing discernment and does not take the first thing that comes. To which we may add that Brandes Headphones will convince the severest critic as undoubtedly worth at a reasonable cost—and always a safe investment. Try the "Matched Tone" feature as a means to perfect reception. Any good Dealer has Brandes.

Manufactured at Slough, Bucks, by

Brandes, Limited, Walmar House, 296, Regent Street, London, W.1.
Glasgow—47, Waterloo Street. Newcastle—5/6, Post Office Chambers.

Matched Tone

TRADE MARK

Radio Headphones

'Phone—Mayfair
4208-9.

*Trade enquiries
invited.*

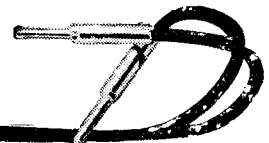

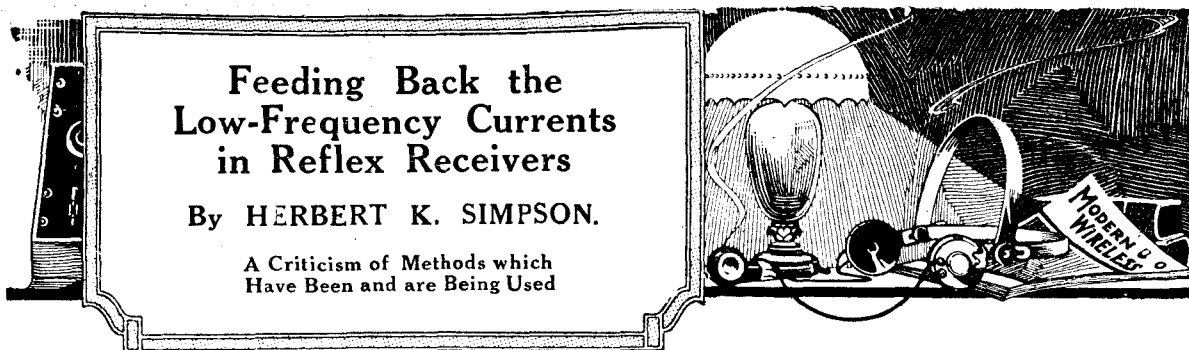

Feeding Back the Low-Frequency Currents in Reflex Receivers

By HERBERT K. SIMPSON.

A Criticism of Methods which Have Been and are Being Used

THE prevalent popularity of the dual, or reflex, type of receiver is due to the fact that an economy of one or more valves is obtained by the use of the principle, which is, briefly, that a three-electrode valve may be used as a high-frequency amplifier, the oscillations being then detected by means of a valve or a crystal, and the low-frequency currents being reintroduced into the grid circuit of the original high-frequency amplifying valve and amplified by that valve, which consequently is amplifying high and low-frequency currents simultaneously.

A dual receiver may look very simple on paper, but actually it has taken some ten years to develop the dual circuit into something which is sufficiently stable for general use.

About a year ago dual circuits were almost unknown to the average experimenter, although credit must be given to P. G. A. H. Voigt, who was trying to interest his fellow-experimenters in this class of circuit (see, for example, MODERN WIRELESS, February, 1923, and earlier articles in the *Wireless World*). Very much earlier than this, dual amplification patents were taken out by J. Scott-Taggart and, much earlier, by M. Latour, which latter investigator carried out important

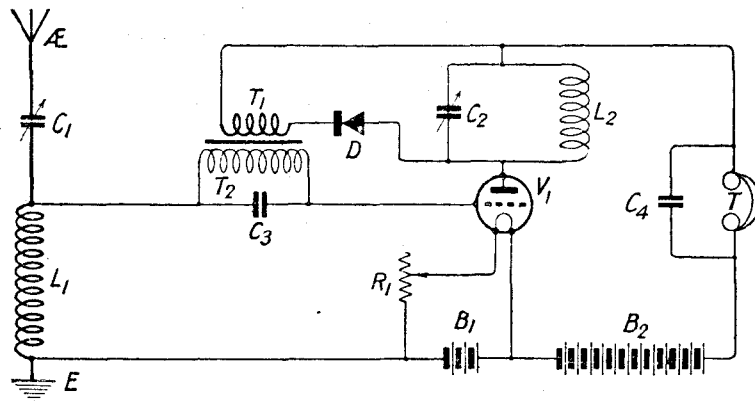

Fig. 1.—An early dual circuit due to Captain Round.

work in connection with multi-valve reflex circuits. Iron-core high-frequency transformers were used for these experiments, which consequently did not have much influence at the time.

Probably the first to use a dual circuit in this country was Capt. Round, of the Marconi Company, who used a circuit very similar to that illustrated in Fig. 1 in 1916, if not earlier.

From this circuit it will be seen that a crystal detector, D, acted as a rectifier of the high-frequency oscillations in the tuned anode circuit L_2, C_2 , and that the low-frequency rectified currents were fed into the grid circuit of the valve by means of the transformer T_1, T_2 ,

the secondary of which was connected in the position shown. It would seem from this circuit that at this date the problem of feeding back the low-frequency currents, which seems so simple nowadays, was an appreciable one.

When using loose-coupling between a separate aerial circuit and a secondary circuit the problem does not arise to any extent, but when using the very convenient direct-coupled arrangement of Fig. 1 some stable methods of introducing the low-frequency currents must be devised.

Fig. 2 shows the method of feeding back the low-frequency currents which was, until recently, accepted as the proper method with the very natural result that everybody regarded a dual circuit with horror, due to its instability and tendency to howl at the slightest provocation when the telephones, the accumulator or the high-tension battery were touched.

It will be seen from Fig. 2 that the left-hand side of the secondary T_2 of the intervalve transformer is connected to earth, and the other side to the filament accumulator. Since low-frequency currents are flowing through T_2 , varying potentials are established across the ends of this coil, but since the left-hand end is permanently connected to earth, it is the right-hand end which

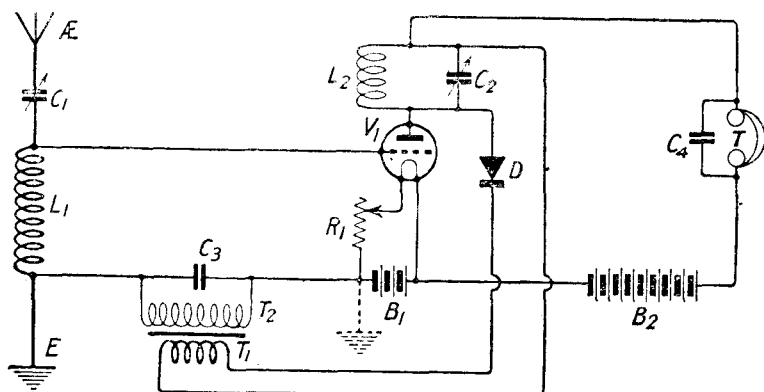

Fig. 2.—A feedback method used until quite recently.

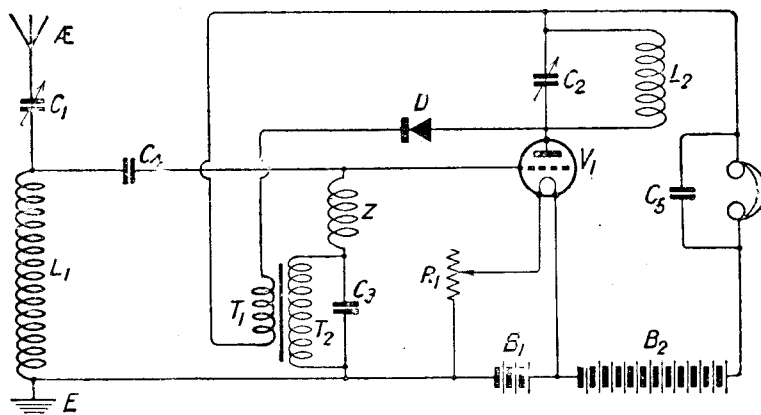

Fig. 3.—Captain Round's solution of the instability problem.

has its potential varied at low-frequency. Consequently anything connected to this right-hand end will also have its potential varied up and down at low-frequency with respect to earth, and so we see that the filament accumulator B_1 , the high-tension battery, and the telephones are all fluctuating in potential with respect to earth.

Owing to the large bulk of the accumulator and high-tension battery and the fact that the telephone receivers are fitted on the head of the operator, these pieces of apparatus, which are all connected together, are substantially at earth potential, and to indicate this an earth is conventionally shown in dotted lines connected to the negative terminal of B_1 in Fig. 2. The natural result of touching any of the points mentioned will be to weaken signals, and, as a matter of fact, frequently to set up a low-frequency howl. In addition a large extra capacity is connected across the winding T_2 , and in some cases there may even be a leakage path across this transformer due to imperfect insulation of the batteries or the headphones.

In the Round circuit of Fig. 1 these troubles do not arise. The accumulator, high-tension battery and telephones are all connected to earth. On the other hand, however, the position of the secondary T_2 is not good from a very fundamental point of view, but at that time perhaps this was the lesser of two evils. The connection of a transformer, which is a bulky piece of apparatus, in the grid circuit at a point at high-frequency potential to earth could only have the effect of weakening the high-frequency potentials across L_1 . It is to be noted that there would be a capacity effect between the primary T_1 and the secondary T_2 , one end of which is practically connected to earth, via C_4 and the batteries.

The arrangement of Fig. 1 leaves much to be desired from the standpoint of the modern experimenter.

Fig. 2 we have already discussed, and the reasons for its defects have been outlined, although in skilful hands or in special circumstances this circuit may be erected without low-frequency oscillation.

The two real solutions of the problem are what may be respectively called the Round and Scott-Taggart methods. Each of these has its advantages.

Fig. 3 shows the Round method, in which it will be seen that one end of the secondary T_2 of the intervalve transformer $T_1 T_2$ is connected to earth, and the other is connected through the choke coil Z , which is of the air-core pattern, to the grid of a valve. A condenser C_3 , which should not have a value above about $0.001 \mu F$, merely serves to prevent the low-frequency currents provided by T_2 from being short-circuited through L_1 , while the choke coil, Z , chokes back any high-frequency currents which try to pass through C_3 . This circuit is stable, and also possesses the great advantage that interference from

electric light mains is a minimum. Interference from electric light mains is not appreciable in the case of the Fig. 1 and Fig. 2 circuits, but sometimes a certain amount of trouble is experienced with the Fig. 4 circuit, though individual reports differ greatly.

The reason for the interference, in the case of Fig. 4, which, however, is considerably lessened by the use of a series condenser in the aerial circuit as shown, is that one end of the grid circuit is earthed and the other end is connected to the aerial which sticks up by induction from the electric light system, one pole of which is also very frequently earthed.

In the case of a circuit like that of Fig. 3, any low-frequency currents induced from the electric light mains in passing through L_1 set up practically no potential differences across L_1 , because of the small inductance and resistance of this coil. In the case of the Fig. 4 circuit, the currents in traversing the secondary T_2 of the transformer, set up more substantial E.M.F.s which are then communicated to the grid of the valve and amplified by it.

The disadvantage of the Fig. 3 arrangement is that an extra condenser C_4 and an air-core choke Z is required. Most experimenters will experience a small loss in signal strength as a result of using the choke Z , which, in the case of broadcast wavebands, should have about 200 turns. Complications are also liable to arise, due to additional high-frequency circuits being formed by the inductance and self-capacity of the choke Z , and different combinations of the inductance Z with the capacities on each side of it, there is a tendency for the choke circuit to act as a rejector on certain particular wave-

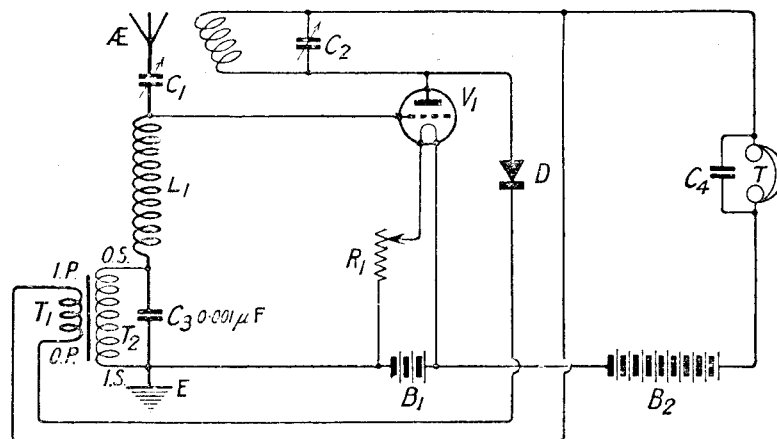

Fig. 4.—The method due to Mr. Scott-Taggart.

LISSENIUM

A STONEWALL WITHIN YOUR RECEIVER

If you use assorted parts, some of these may be good—others may be leaking energy—others may be so useless that they **STAND LIKE A STONEWALL ACROSS THE ENERGY PATH.** Parts of assorted make! Why use them? Every vital part is so important that there is a **LISSEN** part for every vulnerable point of a receiver. If you wish to easily fix responsibility for the behaviour of your set, you will use a **LISSEN** part wherever you can. And we are content that you should do—for **WE GUARANTEE EVERY LISSEN PART TO SATISFY YOU PERFECTLY—we EXPECT TO HEAR FROM YOU IF YOU ARE NOT SATISFIED.**

NOISES ARE DISASTROUS TO CLEAR RECEIVING.

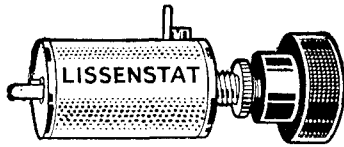

Any noise in a receiver gets multiplied many times with each stage of amplification. A rheostat that does not pass a steady current excites extraneous noises in the valve. You may think any device for filament control is good enough—**BUT IS IT?** Those who value fine detection are fitting **LISSENSTAT** control—its improved effect on tuning is at once noticeable—here is a control that keeps your valves quiet—**THROUGH A DEAD BACKGROUND OF SILENCE STATIONS COME THROUGH THAT PREVIOUSLY ELUDED EVERY OTHER CONTROL OF THE RECEIVER**—stepless, noiseless, perfect control from the first turn to the last. Fit one **LISSENSTAT**, and you will surely have all your valves **LISSENSTAT** controlled. There are three types to choose from—each is suitable for dull emitter and all valves.

LISSENSTAT (prov. pat.). This is the super filament control—gives the valve a chance to do its utmost—every change of electronic emission can be accurately regulated—very necessary for long distance work. **7/6**

LISSENSTAT MINOR (prov. pat.). There must be many hundreds of thousands of inefficient rheostats in use. To provide something of the beautiful **LISSENSTAT** control at a popular price the **LISSENSTAT MINOR** has been introduced. This will make it worth while discarding any existing device, it is a perfect little control and will be much appreciated in use. **3/6**

LISSENSTAT UNIVERSAL (prov. pat.). When dull emitter valves are used, the bottom adjustment should be withdrawn to its fullest extent and locked by means of the locking nut provided. At this adjustment of the bottom control, when the top knob comes into operation, the maximum resistance possible with the **LISSENSTAT UNIVERSAL** is in circuit, and when the top knob control has been turned to the limit of its downward travel, a minimum resistance is still in circuit which protects the valve from overloading. Zero resistance can also be obtained. Gives all the beautiful **LISSENSTAT** control **10/6**

TO THOSE WHO MAKE THE MISTAKE OF THINKING THAT LISSENSTAT CONTROL IS THE SAME THING AS AN ORDINARY RHEOSTAT—LET THEM TRY THE DIFFERENCE.

JUMPING ACROSS THE GRID.



ELECTRONS! Think how they jump across! Positive and negative electrons alternating—**IF THE GRID LEAK RESISTANCE IS CORRECT.** If there is no means of regulating grid potential, however, the grid of the valve will become highly positive, and this will stop the electronic flow between filament and plate. With some circuits and some valves variable grid control is not so important, but with others it is extremely necessary. By using the **LISSEN Variable Grid Leak (prov. pat.)** the exact value of leak resistance can be selected to suit every varying phase of the valve and circuit, and it is of course an excellent thing to be able to obtain correct grid potential all the time. **LISSEN ONE HOLE FIXING, OF COURSE, POSITIVE STOPS BOTH WAYS ... 2/6**

LISSEN Variable Anode Resistance, same outward appearance as the **LISSEN VARIABLE Grid Leak,** continuously variable 20,000 to 250,000 ohms. **2/6**

CHOOSING A TUNER.

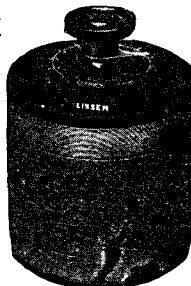

If you do not wish to use plug in coils, there is the **LISSEN Tuner,** with its simplicity of control, its switch complete, its sharp tuning on all ranges with full efficiency at every point, negligible H.F. resistance, large inductance for a given length of wire—**LISSEN Multi-wound—150 to 1,000 metres with a 0.0005 condenser (preferably use the LISSEN Mica Variable Condenser, 17/6) 22/6**

Mica Variable Condenser, 17/6 **22/6**

YOUR CONDENSER IN SERIES OR PARALLEL.

Your coils can then be made to cover a double band of wavelength. The **LISSEN Series-parallel switch** is easy to fit—takes up hardly any room—**LISSEN ONE HOLE FIXING, OF COURSE. ... 3/9**

A USEFUL LITTLE SWITCH.

For plain switching in L.F. or H.F. circuits, for instance, this handy little switch will be useful in other ways also—takes up hardly any room—**LISSEN ONE HOLE FIXING, OF COURSE. ... 2/9**

USE A LISSEN PART WHEREVER YOU CAN, and your finished instrument will give much better results than one built with mixed parts.

Can you do it?

Cut out a nearby broadcasting station, or eliminate Morse? Many say it cannot be done, but the **LISSENCEPTOR** has proved otherwise. There are alternative connections, and a diagram with each plainly shows these.

No difficulty will be experienced in cutting out broadcasting. Quite 95 per cent. of Morse will also be easily eliminated. There is a certain type of Morse interference, however, which calls for greater skill. Even where this interference cannot be entirely got rid of by those not sufficiently skilled, however, it can be subdued to the extent that it ceases to spoil the reception of broadcasting programmes. The **LISSENCEPTOR** will be found quite a useful thing to add to any receiver. It can be used outside the set and requires a separate tuning condenser, which should preferably be a low-loss condenser, such as the **LISSEN Mica Variable Condenser, 17/6.**

LISSENCEPTOR Mark I type, for broadcasting, **7/6.**

LISSENCEPTOR Mark 1 type, for 600 metres, **7/6.**

LISSENCEPTOR Mark 2 type, for broadcasting and 600 metres combined (with switch complete for more selective tuning), **15/6.**

The LISSENCEPTOR acts like a sentinel beside your receiver.

Overlap

The Explanation of an Unstable Set. One of the troubles often met with in reaction circuits is that reaction is not even and gradual. For instance, as the coupling is increased the set will suddenly burst into violent oscillation, and as the coupling is decreased the oscillation will continue beyond the point at which it started. This condition is known as **OVERLAP** AND IS A VERY BAD FAULT WITH A REACTION COUPLING. As in practice it means that the oscillation point can never be reached without the set becoming unstable. The **CONSTANTS OF THE LISSEN REGENERATIVE-REACTANCE (prov. pat.)** are so arranged that there is a perfect reaction coupling over the whole range covered. There is no re-radiation either. There is **NO OVERLAP** (providing the correct values of anode and filament voltage are used).



There are other advantages in using the **LISSEN REGENERATIVE-REACTANCE**—it takes the place of plug-in coils. If plug-in coils are used to provide reaction in a tuned anode circuit, only one stage of radio frequency amplification can be used, because it is next to impossible to control two stages of radio frequency amplification with plug-in coils. With the **LISSEN REGENERATIVE-REACTANCE** in the first stage, however, other stages of H.F. can be added as desired, and easily controlled, each stage adding immensely to the sensitivity and range of a receiver. Selectivity is also greatly increased when the **LISSEN REGENERATIVE-REACTANCE** is used—nearby broadcasting stations can be tuned out, and the others brought in with full built up strength. Much American telephony has been successfully received on two-valve sets. Then, again, a set of plug in coils to cover the same wide range would cost more than the **LISSEN REGENERATIVE-REACTANCE**—no coil-holder to buy with the latter, either.

This **LISSEN Part** is provided complete with internally connected switch all ready mounted—no soldering—no complications—blue print with each shows easy connection—**LISSEN ONE HOLE FIXING, OF COURSE, 750 to 1,000 metres. 52 12s 6d.**

Tune always with a variable condenser (preferably use the **LISSEN VERNIER**, which is specially designed for fine tuning in H.F. circuits, barely 1 in. diameter). **12/6.**

CONSIDERATIONS IN AUDIO FREQUENCY AMPLIFICATION—Where LISSEN Design Scores.



Power output and distortionless amplification depend upon the impedance of the audio-frequency transformer equalling the internal impedance of the valve circuit before it as nearly as possible. It is not necessary to match impedance exactly, but it is desirable to get somewhere near it.

The windings of the **LISSEN T1 Transformer** are such that the resonant point is far beyond the reach of all audible frequencies. It is the mistake of some designers to use wire which is too fine. The **LISSEN Transformers** are all heavily wound. The **LISSEN T1** particularly

so. It will give everlasting service under all possible conditions. The price of this **LISSEN Transformer** should be about 1/2 in comparison with the coils put in some transformers which are sold at high prices. The **LISSEN T1** is practically all coil. Its weight is **COPPER WEIGHT**, not iron weight. It may be used throughout where superlative amplification is desired, but it should always be used **IMMEDIATELY BEHIND THE DETECTOR VALVE, AND ALSO FOR POWER WORK.** It has a coil which would amplify by itself without any iron core at all. **AMPLIFIES A WHISPER IN A BACKGROUND OF SILENCE. Price 30/-.**

AUDIO-FREQUENCY IN REFLEX CIRCUITS.

It has been found that the **LISSEN T2 Transformer** is a fine transformer in these circuits, including the **ST 100**, where it yields pure and powerful amplification. **25/-.**

AN EXCELLENT LIGHT TRANSFORMER.

One of the best light transformers made is the **LISSEN T3.** May be used for all stages. A really excellent transformer and actually compares with many expensive transformers because of its skillfully balanced design. **16/6.**

FIT A LISSEN TRANSFORMER—AND MAKE SURE.

LISSEN LTD. 20-24, Woodger Road, Goldhawk Road, LONDON, W.12.

Phones: 3380, 3381, 3382, 1072 Hammersmith.

Telegrams (Inland): "Lissenium, Shepherds, London."

Telegrams (Foreign): "Lissenium, London."

BUILD—WITH LISSEN MASTER PARTS.

ARMSTRONG BRITAIN LTD
MONARCH LAUNDRY
 LEVENSHULME
 2nd April, 1924 Manchester

GENTLEMEN

No doubt you are aware, for many months I have been on the look-out for a satisfactory Detector Valve for my large Receiving Set supplied by you; I have tried almost every valve on the market (for some of which I paid as much as 35/-), but have not been satisfied until I tried the Thorpe at 10/-. It just does what I want, and makes no fuss about it. It is a topping detector, bringing in all stations of the B.B.C. Loud-Speaker Strength without Reaction. I am sorry to confess that I kept off it for a time, thinking it could not be much good at the price. Thanking you for bringing it to my notice,

I am,
 Yours faithfully,
 B. H. BRITAIN.

"A topping detector"
 -better than the best
 at ONE THIRD the price

We are publishing this testimonial because we feel there may be thousands of other people still clinging to the fallacy that an article of low price is necessarily of low quality.

If YOU have not yet tested the Thorpe K.1 Valve buy one to-day. The results would even justify scrapping the one now in use. OF ALL DEALERS.



Sole Agents: Bower Electric Ltd., 15, Grape St., Shaftesbury Avenue, W.C.

LENGTH • 2 3/4"
 HEIGHT • 2 1/4"

Diagram showing dimensions: 2 3/4" (width), 2 1/4" (height), and 2 1/4" (depth).

PRICE
15/-

SEE YOU BUY TRANSFORMERS SCIENTIFICALLY DESIGNED—YOUR CHOICE WILL BE H. T. C.

Proved exceptionally efficient on the S.T.100—one of the most rigorous tests to which a transformer may be subject. May be used on all dual circuits as it will stand the high voltages without breaking down.

We can supply the "Correct" DUBILIER CONDENSER for the primary of the H.T.C. TRANSFORMER, specially fitted with connections all ready for easy assembling on the Transformer, at 3s. EACH.

If your local dealer cannot supply write direct to:
H.T.C. ELECTRICAL CO., LTD.,
 2 & 2a, BOUNDARIES ROAD, BALHAM, S.W.12.
 Trade Enquiries Invited. TELEPHONE: Battersea 374.

50% Higher Efficiency
 than an Ordinary Condenser

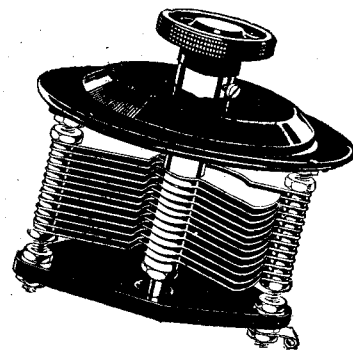

Edge effect losses reduced to a minimum; capacity ratio of 150 to 1 in the .0005 type; equal distribution of wavelengths throughout the whole length of scale; astonishingly high selectivity—these are characteristics of a new Condenser we have designed on the true Square Law Principle. The new condensers are no larger than the ordinary type, yet it is safe to say that they will add at least 30 per cent. to the efficiency of any set to which they may be fitted.

(Prov. Pat.)
BOWYER-LOWE TRUE PRINCIPLE SQUARE LAW CONDENSERS

A Revolutionary Invention

The new condensers are made in three types, Standard, Vernier and Double. The whole length of their scales is equally valuable. There is no crowding at the lower end.

Write at once for full particulars of these remarkably efficient components—the ultimate type.

BOWYER-LOWE CO. LTD. Letchworth.

lengths, and the circuit also acts as a rejector circuit on certain harmonics of its own natural frequency.

These peculiarities and complications are entirely absent in the Scott-Taggart method shown in Fig. 4, which may be adapted to any type of reflex circuit.

Another disadvantage of the Round arrangement is that different sized chokes are required for different ranges of wavelengths, so that a choke suitable for the broadcast waveband would not be suitable for receiving the Eiffel Tower. The circuit of Fig. 4, however, works independently of wavelength changes, but on the other hand it is a matter of trial in individual cases to find out whether too much interference from electric light mains is experienced with the Fig. 4 arrangement. If this effect is obtained, the Fig. 3 circuit should be tried.

Many very interesting experiments may be conducted in trying out these different forms of feedback.

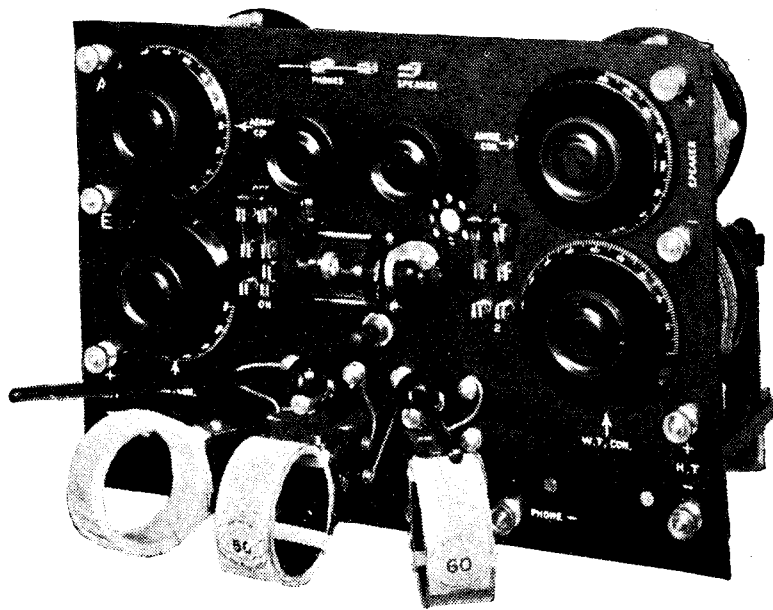

An elaborate S.T. 100 receiver built by a London reader. A wavetraps is included and an additional vernier condenser.

Why You Should Do It.

THE following are some of the advantages of starting your letter: "Dear Sirs,—In reply to your advertisement in MODERN WIRELESS, please . . ."

1. The advertiser is much more likely to despatch your goods to your satisfaction.
2. If you have mentioned this journal in your letter, you have

practically insured yourself against any possible disappointment. In no case where a reader has appealed to us has he failed to obtain immediate satisfaction. Great care is taken in accepting advertisements only from responsible firms, but isolated cases have occurred where complaints have been made to us. We take these up immediately, and any failure to satisfy one of our readers results in the advertiser being barred from these pages. This firm attitude is appreciated

by all genuine firms, and by readers themselves. When you begin your letter by mentioning MODERN WIRELESS, you are backed by all the influence a powerful journal possesses.

3. It is the sporting thing to do, because the success of a journal depends upon its advertisers, and the mention of MODERN WIRELESS indicates to the advertiser what a valuable advertising medium this journal is; this in turn helps us.

THANKS!

To a Friend I Never Knew

You may search for Two Oh Emma,
but his voice will never come,
His station now is silent and his
generator dumb;
In vain you'll twist the dials, never-
more you'll hear that hum —
The O' Man's gone!

There's a wailing on his wave-
length, and the ether's full of
moans
Where formerly we listened for his
sweet and dulcet tones.
Five Vic R is so disconsolate he
scarcely dons the 'phones,
Now the O' Man's gone!

Not lost, but gone before us, trans-
lated to those spheres,
Where he still retains the Emma but
precedes it with Six Beers,
In short, it's down to Bournemouth,
with the Broadcast Engineers,
That the O' Man's gone!

RALPH H. ALDER.

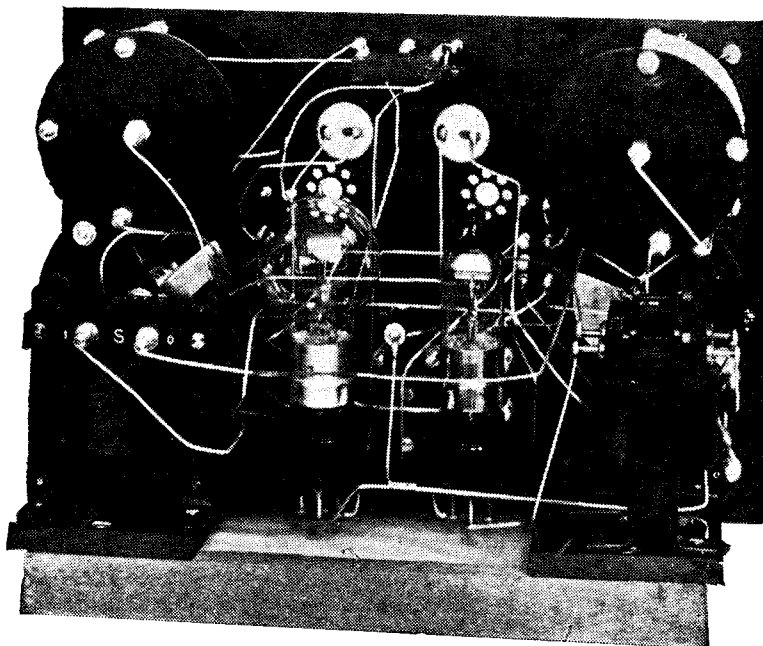

Rear view of the instrument, showing internally mounted valves.

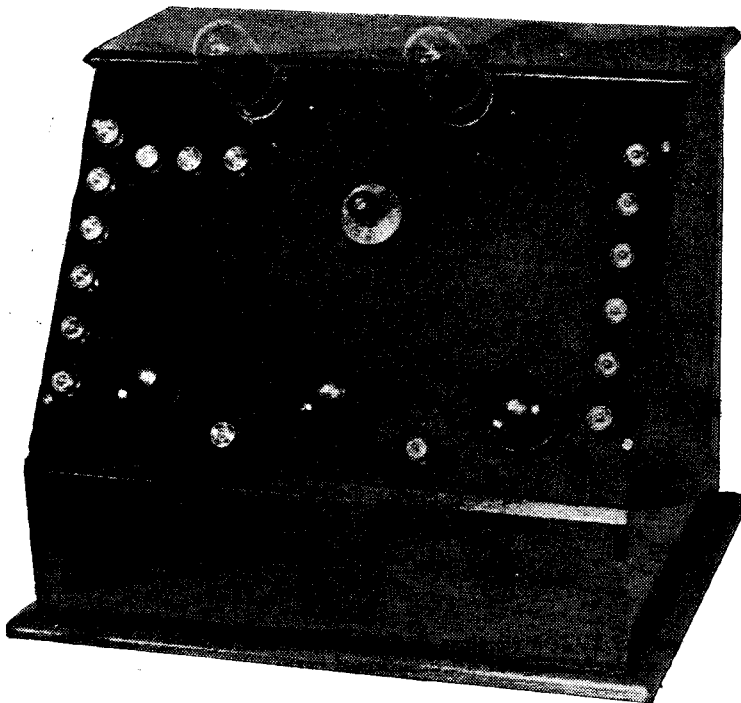

Fig. 1.—The simplicity of controls is immediately apparent.

A Two-Valve Double Purpose Receiver

By
HERBERT K. SIMPSON.

A two-valve set which may either be used as a detector and one note-magnifier, or as two note-magnifying valves.

A USEFUL type of set is one which can be changed at will to fulfil some other purpose. The set in question is designed to act as a rectifying valve followed by one note-magnifier, while by a few external links the rectifying valve is turned into a note magnifier, a two-stage amplifier being the result. No tuning arrangements are incorporated in the present set, the same being designed for use with an external tuner.

Looking at the photograph, Fig. 1, it will be seen that there are nine terminals on the left of the set, two in the front at the bottom, and six on the right-hand side. The nine on the left are those by means of which the circuit is changed, the two in front are for telephones, while the right-hand row are battery terminals. Two Burndept filament resistances and one potentiometer of the same make are incorporated in the set and are located along the bottom of the panel; the two valve-holders are seen at the top, while lower down is the variable grid leak.

Circuit Diagram.

The circuit arrangement of the receiver is seen in Fig. 5, and a study of this will make the connections clear. Terminals 1 and 2 are reaction terminals, used when the first valve acts as a detector. Terminal 3 is the connection to the grid leak and condenser, while the grid of the first valve is con-

nected directly to terminal 8. To use the set as a valve detector with reaction and one note-magnifier, the following connections are made :

Reaction coil to terminals 1 and 2.

Connection from aerial to terminal 3.

Connection from earth to terminal 4.

Terminal 8 to terminal 9.

Leave terminals 5, 6, and 7 free.

A diagram showing how the set is connected up to a tuner when used in this manner is seen in Fig. 6, which shows a simple tuner connected to the set. If a loose coupled tuner is used, the ends of the secondary coil are connected to terminals 3 and 4 instead of the connections given above.

When the set is to be used as a two-stage note magnifier, the following connections are made:

Connect terminals 1 and 2 together.

Output from detector to terminals 5 and 6.

Connect terminal 7 to terminal 8.

Leave terminals 3, 4, and 9 free.

A diagram of the circuit arrangements when the set is used in this manner is given in Fig. 7, which shows a simple crystal set coupled to the amplifier. The telephone terminals of the crystal set are connected to terminals 5 and 6 of the amplifier. Terminals for grid bias are provided, and when no battery is used, these should be shorted by a short external link. The amount of grid bias applied can be varied by means of the potentiometer, thus permitting the correct voltage to be applied to the grids of the valves.

Components.

The components required are few in number, and most of the parts may already be in the possession of the amateur. The prices given are retail, and, of course, only apply to the respective articles named. It is not essential that the parts should be of the make specified, and any good make of article will be found quite satisfactory.

Burndept Dual rheostats have been incorporated in this set, as by this means no alteration to the set is necessary should dull emitter valves be used.

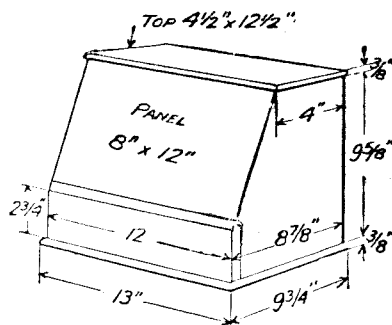

Fig. 2.—The containing cabinet.

Charge Your Own ACCUMULATORS AT HOME FREE OF ALL COST



Cut out the continual weekly expense of having your accumulators charged. Eliminate the annoyance of being left with accumulators run down just when you want them most and the trouble of carrying them to the nearest garage for re-charging.

Do away with all this NOW, by charging your own accumulators at home and absolutely without cost.

If you have a direct current lighting or power circuit of any voltage all you need to charge your own accumulators at home is the

ULINKIN

(Prov. Pat. No. 5002/23)

THE D.C. HOME BATTERY CHARGER

which charges your accumulator free of cost whenever you are using electricity for lighting or heating purposes.

Requires no attention and cannot go wrong.

AUTOMATIC IN ACTION
NO LAMPS NO RESISTANCE NO REGULATOR
PRACTICALLY EVERLASTING

Price **£2 - 2 - 0** complete.

Carriage Free with complete simple instructions for fixing
Illustrated Pamphlet FREE on request.

Sole Distributing Agents:
THE GRAN-COLEMAN SERVICE
 (Dept. M.4),
 71, Fleet Street, London, E.C. 4.
 Agents wanted.

For Direct Current only.

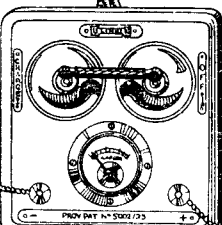
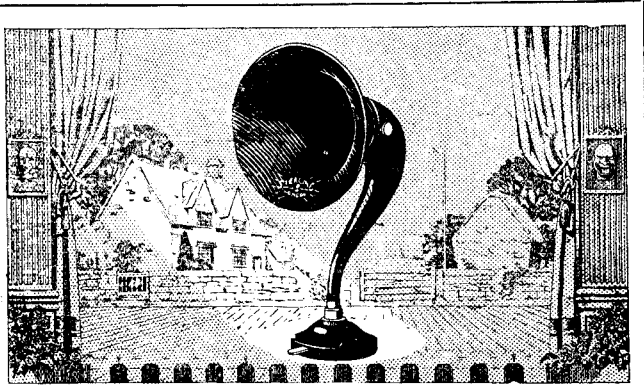
The most popular Entertainer in the World

No entertainer ever had a bigger or more appreciative public than the "Sterling" Baby Loud Speaker. In thousands upon thousands of homes throughout the length and breadth of the country this amazing little instrument daily renders a programme that brings absolute delight to musicians, perfect pleasure to dancers, endless amusement to kiddies and ever varied interest to all.

The "Sterling" Baby Loud Speaker is flawless in reproduction, natural in tone, distortionless, and wonderfully loud for its size. It is supplied in the following finishes and in two resistances: 100 and 2,000 ohms.

- In Black Enamel £2 : 15 : 0
- In Brown Floral Design £2 : 17 : 6
- In Black and Gold Floral Design £3 : 0 : 0

Ask your dealer to demonstrate the Sterling Baby Loud Speaker

the best of its class

Advt. of STERLING TELEPHONE and ELECTRIC CO. LTD.

Manufacturers of Telephones and Radio Apparatus, etc.

210-212 TOTTENHAM COURT ROAD, LONDON, W.1

Works: DAGENHAM, ESSEX

*Phones: REGENT 609. EAST HAM 172. WIMBLEDON 2398.

I. R. M. VALVE SETS



These exceptionally neat and highly efficient sets employ the well-known tuned anode circuit with reaction on the anode. Where conditions are favourable these sets will receive all British Broadcasting; also Paris and The Hague.

For short distance reception an indoor aerial can be used. In the case of the Three and Four Valve Sets the rectifying valve is followed by one or two note magnifiers respectively, which enable the sets to operate a loud speaker on all stations. The Two and Four Valve Sets are the same in size and appearance as the Three Valve Set illustrated above.

PRICES:
2 VALVE SET £7 7 0 plus £2 Royalties and Fees.
3 VALVE SET £10 10 0 plus £2 17 6 Royalties & Fees.
4 VALVE SET £13 13 0
SPECIAL 4 VALVE SET (with cut-out switches) £17 17 0 (Marconi and B.B.C. Royalties £3 15s. extra.)

The above sets can be supplied in parts for home construction at the following prices complete:—2 Valve, £5 5s.; 3 Valve, £7 7s.; 4 Valve, £10 10s. (plus Royalties in each case).

Improved Wave-Trap, which, attached to any set, will cut out interference from any station although only ½-mile away. 25/-, including plug-in coil. Please state wavelength to be eliminated.

The "N.S." Accumulator. This wonderful accumulator may be fully charged in one hour. It will not sulphate under any circumstances whatever. Write for particulars.

PRICES:
 4 volt, 30 A.H. actual, £1 2s. 6 volt, 30 A.H. actual, £1 10s. Carr. forward.

WE SUPPLY EVERYTHING WIRELESS. SEND US YOUR INQUIRIES. SEND FOR ILLUSTRATED LISTS.

INTERNATIONAL RADIO MANUFACTURERS, Ltd.,
 16, Palace House,
 128, Shaftesbury Avenue, W.1,
 and at 39, Station Rd., Manor Park, E. 12.



WIRELESS VALVES J U D G M E N T

in the

HOUSE OF LORDS

In the case of The Marconi's Wireless Telegraph Co. Ltd., v. The Mullard Radio Valve Co. Ltd., their Lordships after careful consideration

UPHELD THE MULLARD RADIO VALVE

Company's claim, that they in no way infringed the patents of the Marconi Co. They therefore *unanimously* confirmed the judgments of the First Court and Court of Appeal and dismissed the Marconi Co's petition with costs.

J U D G M E N T

THE PEOPLE

The judgment of the people is equally clear. More Mullard valves are sold than any other kind.

THE REASON

The Mullard Radio Valve Co. Ltd., own and operate nearly one hundred valve patents, every one of which implies a definite advance in valve construction and makes every Mullard valve a *Master Valve*.

Be wise. Ask for them by name.

Mullard

THE MASTER VALVE

The Mullard Radio Valve Co. Ltd., Nightingale Works, Nightingale Lane, Balham, S.W.12.

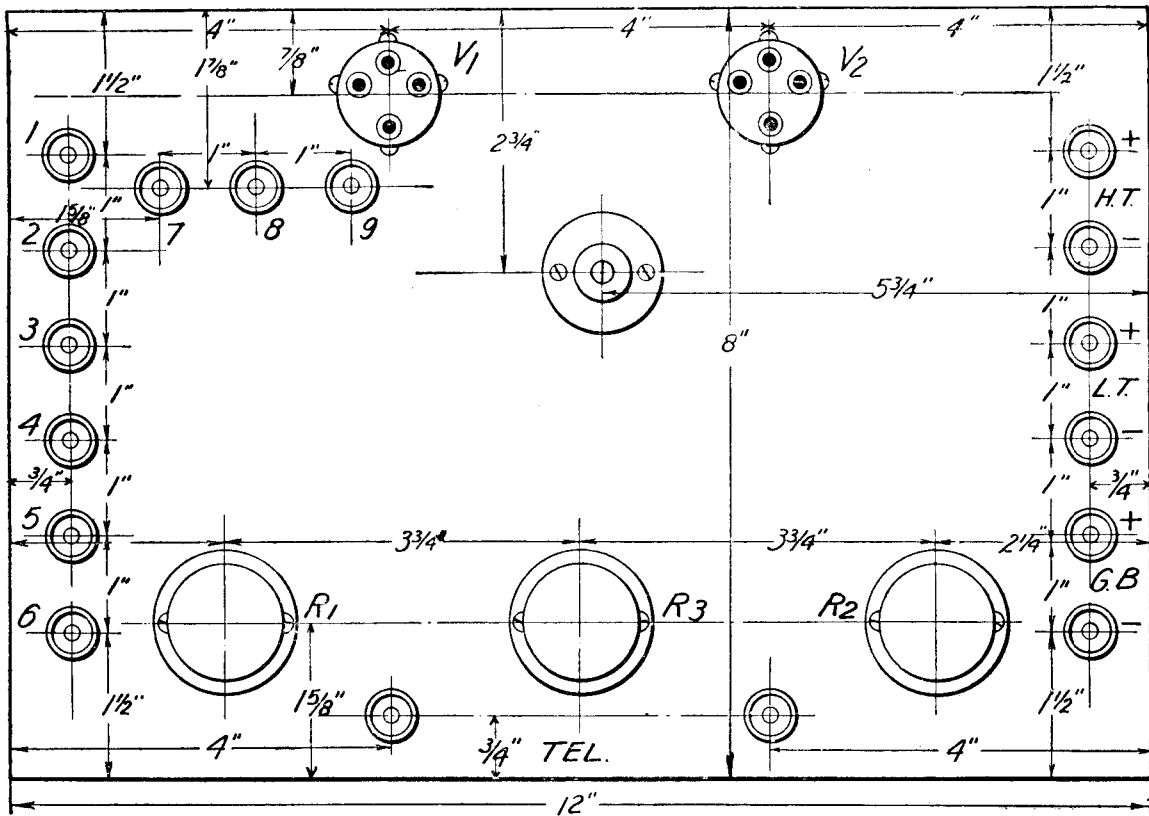

Fig. 3.—A half-size diagram of the panel, showing how to drill the holes and mount the parts.

The Goswell valve-holders are of a neat design, which does away with soldering, and also obviates accurate drilling of the panel. The usual four holes are drilled in the panel, but they do not have to be so accurate as if separate valve-

legs were used. One hole in the centre allows a screw to go through the panel to secure the valve-holder in position, and the connecting wires are passed through the holes in the panel and secured to the correct socket in the holder

by means of small screws provided on the sides of the holder.

The Panel.

The panel, which is of ebonite, measures 8 in. by 12 in. and is 1/4 in. thick. The skin should be

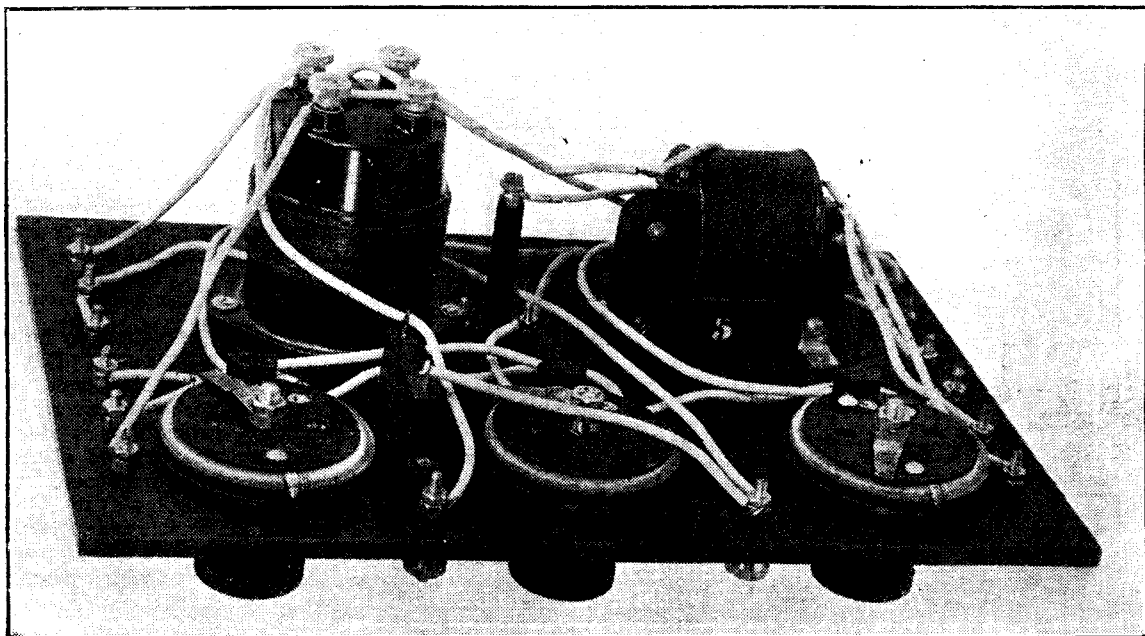

Fig. 4.—The wiring of the set can be followed from this photograph.

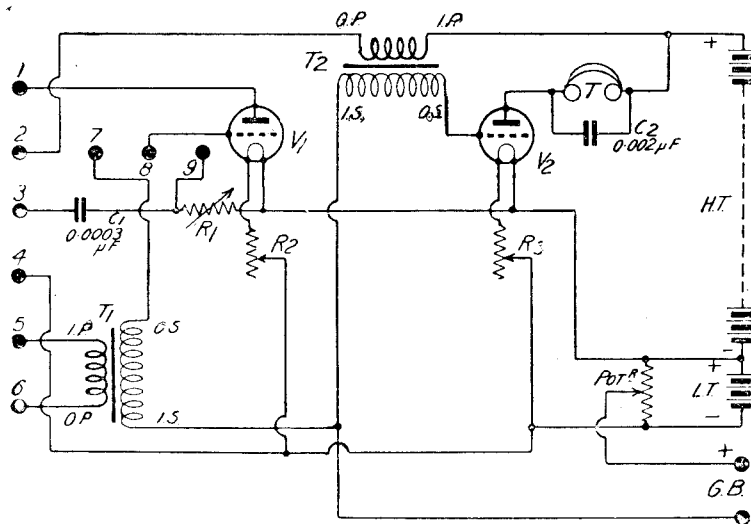

Fig. 5—The circuit diagram of the unit.

COMPONENTS	l.	s.	d.
Cabinet (Wright and Palmer) ...	18	0	
Panel, 3 in. by 12 in. by 1/4 in. ...	4	0	
2 Legless Valve holders (Geswell Eng. Co., Ltd.) ...	3	0	
2 Burndept Dual Rheostats ...	15	0	
1 Burndept Potentiometer ...	7	6	
1 Supra L.F. Transformer (Wates Bros.) ...	12	6	
1 M.L. L.F. Transformer ...	1	10	0
Fixed Condensers } one 0.0003 μF ...	2	6	
} one 0.002 μF ...	3	0	
1-4 B.A. W.O. Type Terminals ...	2	1 1/2	
1 Watnet Grid Leak ...	2	6	
Screws, wire, etc. ...			0 1/2
Total	55	0	11

removed by rubbing with fine emery cloth until the glossy surface has entirely disappeared, after which the necessary holes should be drilled. A drilling diagram is seen in Fig. 3, and all the necessary dimensions are given to make the drilling of the panel a simple matter.

The panel should be marked out

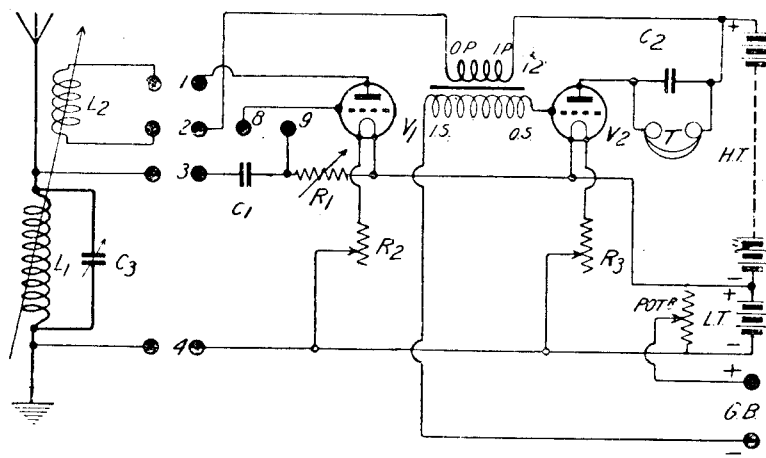

Fig. 6.—Showing how to connect the unit to a tuner, with reaction.

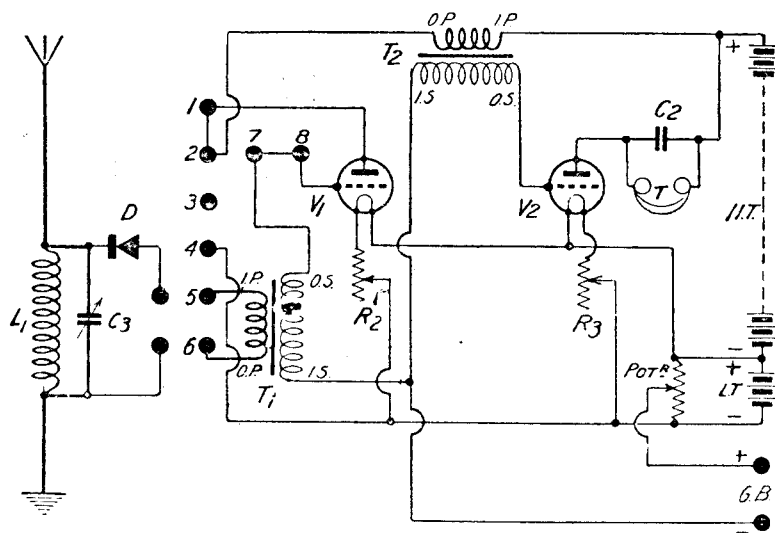

Fig. 7.—To use the set as an amplifier after a crystal set, the connections indicated above are made.

with a sharp-pointed instrument on the underside, and the holes of one size drilled first. The drill is then changed and holes of the next size drilled. This saves much time and is undoubtedly the easiest method of drilling a panel. The writer has previously suggested that the transformers be mounted upon a separate piece of ebonite, which in its turn is mounted upon the panel. This saves redrilling the panel should the type of transformer be changed at any time. A careful worker will be able to drill the holes to hold this strip of ebonite, not quite through the panel, and then a bolt can be forced in in the same manner as a wood screw is forced into a hole in a piece of wood. The bolt makes its own thread and holds quite tight if the hole is deep enough. In fitting the bolt it should be eased in and out several

times, giving the bolt a slightly further turn each time. If this is done and the condensers and transformer platforms are mounted in this way, the panel can be made entirely free from screw-heads, thus giving a much neater appearance to the finished set.

Wiring Up.

The next operation to be done is to wire up the parts. This is an exceedingly simple task when tinned copper wire covered with systoflex tubing is used. Stiff wire may also be used if desired, but this requires more careful laying out and soldering; it is much neater in appearance, however, than the insulated wire.

Each point to which a wire has to be joined is numbered, and a table of points to be joined will be found below; this method renders wiring up an easy matter,

VARIOMETER TUNING

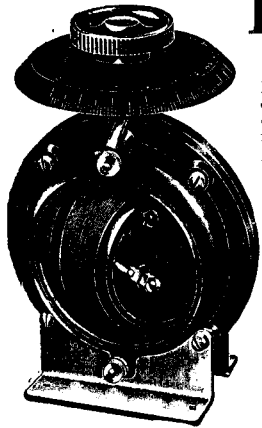

EDISON BELL VARIOMETER.

Fully tested for the efficient reception of Broadcasting and designed to permit of exceptionally fine tuning. Inductance ratio of this Variometer is the highest possible, being 9.5 to 1.

Wavelength range, 200-700 metres.

No. 15370.

Price **15/-**

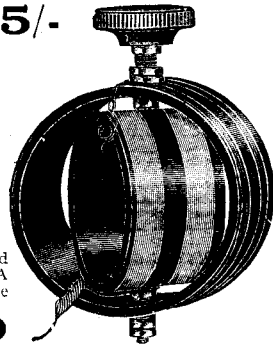

B.B.L. VARIOMETER.

Formers are of ebonite composition and are wound with silk-covered wire. A most efficient aerial tuning inductance for either valve or crystal sets. One hole fixing. Price **4/9**

No. 15350.

Please order from your dealer, we cannot supply direct.

Brown Brothers with which is amalgamated
Thomson & Brown Brothers Ltd.

Wholesale only. Head Offices and Warehouses:

GREAT EASTERN ST., LONDON, E.C. 2. 118, George St., Edinburgh, and Branches

Specify Woodhall Components, and get the best results.

Don't buy un-named Components, however good they may look. See the name "WOODHALL" on every part, and you have a guarantee against any faults that, however small, may cause disappointment.

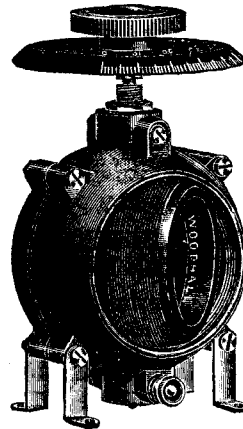

The WOODHALL Variometer, No. 1 (Patents Pending)

Stator windings internally mounted; clearance between Rotor and Stator less than $\frac{1}{16}$ th in. giving probably closer coupling than any other Variometer on the market. A wide range of wave-lengths—250 to 750 metres on 100ft. aerial. The spindles are of square section, actually milled into the rotor; they cannot work loose, as in the case of other Variometers, in which the spindles are merely screwed into the rotor.

A long metal-to-metal bearing is provided, and the connections, putting the rotor in series with the stator, are by means of spring plungers, fitted internally.

To mount on panel, drill one hole only, and lock the nut on the surface of the panel. For board mounting, four brackets are supplied, which allow the Variometer to be mounted either horizontally or vertically (as illustrated).

List price including Knob and Dial **17/-**

The WOODHALL

No. 1 L.F. Transformer

As used by Mr. J. Scott-Taggart in recently described reflex circuits. Unique in its windings, which consist of simultaneously wound silk and wire, eliminating parasitic noise, giving maximum amplification over the entire range of speech frequencies, without distortion. Possesses high current-carrying power which makes it excellent for second or third stage of L.F. ... **23/6**

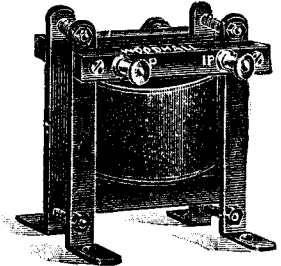

The WOODHALL Special Resistances for S.T. 100 and other Reflex Circuits



Constructed by a new method, sealed against the effect of damp or heat, and guaranteed exact an 1 constant. Mounted on best ebonite base with terminals. Standard resistance 100,000 ohms or can be supplied in any value ... **2/9** from 20,000 ohms to 5 megohms.

The WOODHALL

Panel-Mounting Coil Plug

For addition of loading coil to existing sets, or for many other purposes. Attached through panel from back, giving neat surface appearance; supplied with drilling template. ... **1/6**

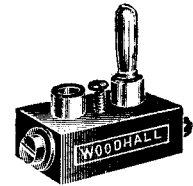

See the name WOODHALL on Variable Condensers, Fixed Condensers, Rheostats, etc., etc., and be sure of the best.

WOODHALL

Guaranteed Components

Ask your Wireless Dealer for them. In case of difficulty send P.O. Direct, giving name of your Dealer. We pay postage. Dealers should specify "Woodhall-Wireless" in ordering from their usual Factors or Wholesalers.

The Woodhall-Wireless Mfg. Co.
55, Cardington Street, Euston, N.W.1

Telephone: Museum 8366.

Wholesale only.

Please your home with the Tone

Your folks at home wonder if they can enjoy summer evenings in the garden with the crowning pleasure of the evening's broadcast?

Let them hear THE BARNES.

The new Model No. 2 is a loud speaker with a heavier output, for reception rooms and for summer radio—the Barnes No. 2 is, indeed, supremely satisfactory.

Purity, quality and richness of tone will exceed any previous experience.

Use the BARNES MINORPHONE No. 2 for summer radio—its power is ample.

Ask your dealer for the

BARNES MINORPHONE MODEL NO 2

and he will gladly demonstrate. It has only to be heard once to merit your distinction. Its good points—pleasing design, volume, freedom from inherent resonance, and a very moderate cost will endorse it—your ultimate choice.

Price **£2 5s.**

If he cannot demonstrate, write giving his name and address to the manufacturers, when we will help you to buy the loudspeaker you want.

L. B. TICKLE & Co., Government Contractors,

61, Borough Road, London, S.E.1

'Phone: Hop 3874. 'Grams: Elbectickle, Sedist

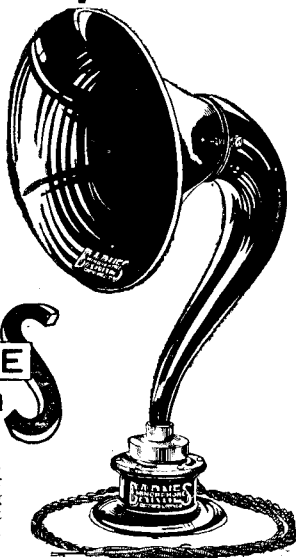

A BRITISH MADE INSTRUMENT FOR BRITISHERS

Of robust construction with large adjustable diaphragm and detachable horn dull-black in finish. The well-designed base is also dull black with polished aluminium top. Resistance 2,000 ohms.

As Always—the C.A.C. Leads the Way.

A really Portable Receiver at Last!

THIS is the most sensitive yet compact Portable Receiver ever devised. It is smaller and lighter than a suit-case, and being entirely self-contained will operate anywhere, indoors or out of doors.

It is absolutely fool-proof, and once set to the wave-length desired may be put into action at once by pressing the master switch. Nonspillable batteries are fitted which operate the instrument for 28 to 30 hours at a time, and can be recharged indefinitely.

NO AERIAL OR EARTH IS EMPLOYED,

so that the Broadcasting may be enjoyed whilst on the river, in a car or aeroplane. Provision is made for instantly attaching an ordinary aerial and earth, when

ALL STATIONS CAN BE RECEIVED ON THE LOUD SPEAKER.

The wave-length range can be extended indefinitely, from 330 to 30,000 metres. Astonishing ranges can be covered with headphones, and as many pairs as desired can be used at once.

THE USES OF THIS WONDERFUL RECEIVER ARE UNLIMITED, AS OWING TO ITS REMARKABLY SMALL SIZE IT CAN BE CARRIED AS EASILY AS AN ATTACHE CASE.

The remarkable performance of the instrument is due to the elaborate care taken in its manufacture and to the amount of research work spent upon it.

THE FOLLOWING POINTS SHOULD BE CAREFULLY CONSIDERED :

(1) PORTABILITY.

The complete Receiver weighs but 16 lbs., and measures only 14 ins. by 12 ins. by 8 ins.

(2) ACCESSIBILITY.

The valves and batteries are instantly replaceable, although protected and concealed when in use.

(3) STABILITY.

A special circuit is employed which is absolutely stable, will not howl and cannot be upset in any way.

(4) RANGE.

20 to 25 miles loud speaker range is normal ; much greater ranges can be obtained with headphones and with an outside aerial anything up to 1,000 miles reception is easily possible.

(5) ECONOMY.

The H.T. Battery will last from eighteen months to two years and the cost of recharging the filament battery will be about one shilling per thirty hours running of the instrument.

LASTLY.

When attached to an outside aerial one has a powerful receiver of unlimited possibilities, capable of giving loud speaker signals with the same economy of upkeep at distances of from 250 to 500 miles.

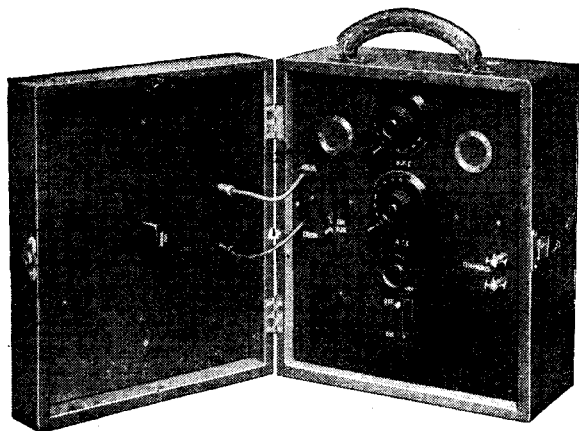

The Price of this wonderful Receiver, complete in every way, but not including 'phones or Loud Speaker, is only

£29 : 15 : 0

NOTE.—This price includes B.B.C. Tariff, 25/-, and Marconi Royalties, £2. If valves are not required, the price is £6 less.

The CITY ACCUMULATOR Co.

10, RANGOON STREET, LONDON, E.C. 3.

Royal 4300—1.

Branches :

10, RUPERT STREET, W. 1.—Gerrard 3063.

79, MARK LANE, E.C. 3.—Royal 4300.

79, OLD CHRISTCHURCH ROAD, BOURNEMOUTH.

Bournemouth 3456.

BRITISH EMPIRE EXHIBITION
Stand Avenue 15, Bay 12,
Palace of Engineering.

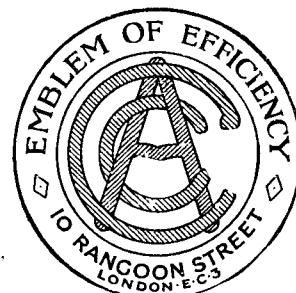

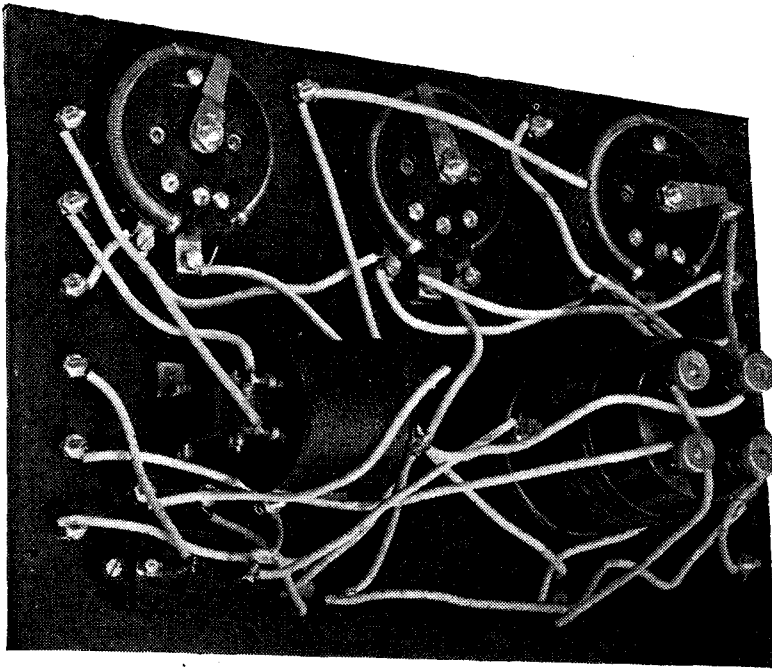

Fig. 8.—Another view of the underside of the panel. Note the Dual filament resistances.

while it is not easy to go wrong. Photographs of the back of the set are given in Figs. 4 and 8, and when used in connection with the wiring diagram, the wiring is easy to follow.

Numbers.

- Circuit terminals 1 to 9.
- Grid Condenser ($0.0003 \mu F$) 10, 11.
- First Valve P, 12; G, 13; Filaments 14, 15.
- Second Valve P, 16; G, 17; Filaments, 18, 19.
- First L.F. Transformer (Wates Supra).

I.P.	20	} P	E
O.P.	21		S
I.S.	22	} S	E
O.S.	23		S
- Second L.F. Transformer (M.L.).

I.P.	24 = +.
O.P.	25 = A.
I.S.	26 = -.
O.S.	27 = G.
- Filament Resistances R_1 , 28, 29.
 R_2 , 30, 31.
- Potentiometer (ends of winding), 32, 34.
moving arm, 33.
- Telephone Terminals, 35, 36.
- Telephone Condenser, 37, 38.
- Grid Leak, 39, 40.
- HT+, 41; HT-, 42; LT+, 43;
LT-, 44; GB+, 45; G.B-, 46.

Connections.

- (1-12) (2-25) (3-10) (4-28-32-30-44) (5-20) (6-21) (7-23) (8-13) (9-11-40) (14-20) (34-39-15-19-42-43) (16-35-37) (17-27) (18-31) (22-26-46) (41-24-38-36) (33-45).

The Wates transformer has the primary and secondary windings marked with the usual P and S, while the two leads to each winding are marked E and s. The correct connections to these are given above, but for clearness it is repeated here that EP is the same as IP and ES is the same as IS. Thus sP goes to plate, and sS to

grid, when the transformer is used in an ordinary low-frequency circuit. The M.L. transformer has its windings marked in a different manner, and the corresponding conventional signs are given above.

The Cabinet.

The cabinet is of the sloping front type, and is fairly simple in construction. The price given is an outside figure which should be paid for a professionally made article. Such a cabinet is advertised as "Type W1" by Messrs. Wright & Palmer, and is the exact type used. For the convenience of those who wish to make their own cabinets, a dimensioned drawing is given in Fig. 2, and should make clear all points in the construction.

Using the Set.

Instructions as to how to connect up the set for each of the uses to which it may be put have already been given and need not be repeated here. When the set is used to amplify the signals from a crystal receiver the connections as in Fig. 7 are made, and the crystal set tuned in the usual way, having previously connected up the batteries and telephones and inserted the valves. Any good make of valve will be quite suitable, and the experimenter may use any valves which he may already possess. By adjusting the potentiometer and high-tension voltage, louder signals may be obtained, while if a power valve is used in the last socket good loud-speaker reproduction will be obtained.

When the set is used as a detector valve followed by one note-magnifier, the connections to the tuner will be as shown in Fig. 6, the

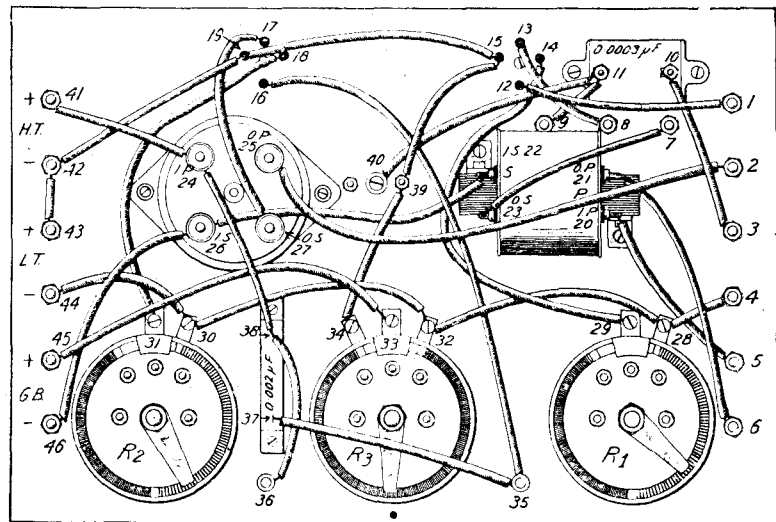

Fig. 9.—A detailed wiring diagram of the back of the panel.

battery and telephone connections remaining the same.

In this case, as only one stage of note magnification is used, the grid bias battery may be dispensed with, and the terminals on the panel should be connected together by a piece of wire. It should be noted that if the grid bias battery is not used, these terminals must be connected together, no matter which circuit is used. In this case a bias may be applied to the grid by means of the potentiometer. When the moving arm is in the centre of the winding, no voltage is applied to the grid.

When used in connection with another valve set, care must be taken that the high-tension negative of the other set is connected to the low-tension positive, as this connection is made in the amplifying unit, and if it were otherwise in the preceding valve set the low-tension battery would be shorted.

The terminals of the existing valve set to which the telephones are normally connected will be connected to terminals 5 and 6 on the amplifier, and the respective terminals for the batteries should be connected together. Terminals 3 and 4 will be left free, while terminals 1 and 2 will be joined.

The set will form a useful addition to an existing receiver, and will be found to give good results on either circuit.

Radio Press Information Department

Owing to the tremendous increase in the number of queries, and the policy of the Radio Press to give expert advice and not merely "paper circuits," it has been found necessary to enlarge our staff dealing with such matters. In view of the expense incurred, we are reluctantly compelled to make a charge for replies of 2s. 6d., according to the rules below.

All queries are replied to by post, and therefore the following regulations must be complied with:—

- (1) A postal order to the value of 2s. 6d. for each question must be enclosed, together with the coupon from the current issue and a stamped addressed envelope.
- (2) Not more than three questions will be answered at once.
- (3) Complete designs for sets and complicated wiring diagrams are outside the scope of the department and cannot be supplied.
- (4) Queries should be addressed to Information Department, Radio Press, Ltd., Devereux Court, Strand, London, W.C.2, marking the envelope "Query."

America on the "All Concert"

To the Editor of MODERN WIRELESS.

SIR,—I am writing this article with the object of offering my congratulations to Mr. P. Harris on his very fine "All Concert Receiver," and also hoping you will find room for this in the pages of your excellent Magazine, of which I am an ardent reader. After purchasing No. 8 of MODERN WIRELESS I decided to make a receiver exactly like the one described. Although I have been very interested in wireless for the past eight years and am fortunate enough to possess an experimental Transmitting Licence, 5 KZ, I can honestly say that I have yet to come across a circuit so selective, in conjunction with ease of handling. The results are splendid. My house is in Keighley, Yorkshire, about forty miles from 2 ZY. Reception of all B.B.C. Stations is in most cases too loud to be comfortable using 'phones and three valves. Using the fourth valve and Brown's loud-speaker all stations with the exception of 2LO are perfectly audible 40 ft. across the road from the house. Continental broadcasting is also exceptionally good. On two or three occasions I have received American amateurs and broadcasting from WJZ and WGY, with good clarity from the latter, although fading at varying intervals was rather noticeable. My set is practically identical with the one described with the exception of series, parallel switching for A.T.C. (.0007) and a .001 fixed condenser across the secondary winding of the last low-frequency stage, which I find does away with a large amount of "mush" and "hiss" in the loud speaker. I use Lissen T.1 and Silvertown transformers, Dubilier condensers both fixed and variable, Ericson resistances, Groggan tuning coils and Cossor Bright emitter valves, 60 V.H.T. Aerial 100 ft. single wire 60 ft. high, earthed to 3 ft. square piece of sheet lead buried three feet underground.

Yours faithfully, R. MITCHELL.
Earl Street, Keighley.

SUPPLEMENTARY CORRECTION

The reversal of the terminals T₃ T₄ mentioned upon another page of this issue as being necessary upon Fig. 7 of the article upon the Three Valve Dual Receiver, should also be made upon Figs. 2, 3 and 4. These are correctly given upon the wiring diagram, which is, of course, the essential guide.

The Rensselaer Polytechnic

To the Editor of MODERN WIRELESS.

SIR,—With respect to the short article in your current issue dealing with the reception of WJAZ, I have before me a letter from the station at the Rensselaer Polytechnic Institute, Troy, N.Y., call sign WHAZ, one paragraph of which reads as follows:—

"This station broadcasts a programme every Monday night at 9 p.m. Eastern Standard Time.—It may interest you to know that these programmes are heard in every state of the Union, in all the Canadian provinces, the Hawaiian Islands, the Panama Canal Zone, England, and France. This station holds the record for long-distance transmission, one of our programmes having been heard in New Zealand, a distance of 9,377 miles from this station."

I myself receive WHAZ with about 70 per cent. regularity using, as a rule, only three valves.

Wishing your very excellent publication all the success it deserves. Believe me,

Yours faithfully,
ARNOLD P. HILL
(B. Eng.).

Wallasey.

Important Announcement

In the next issue of MODERN WIRELESS will appear an important article by John Scott-Taggart, F.Inst.P., A.M.I.E.E., the originator of the S.T. 100 circuit, in which will be given full details of an S.T. 100 set provided with an extra valve for high-frequency amplification.

This set will be capable of giving all the powerful results of the original S.T. 100, with the great additional advantage of a very substantial increase in signal strength and selectivity in long distance work. On no account should any reader miss this important article published on the anniversary of the publication of the original S.T. 100 circuit.

Whether you propose to make the set at once or not should not affect your resolution to see that you get the June issue of MODERN WIRELESS at all costs. Sooner or later you will want to make this set and refer to the article. Place an order with your newsagent and make sure.

ACES

During the war the air-
men who succeeded
against all competitors,
under all conditions, were
called aces.

By the same test the four
Igranic Radio Devices
illustrated here have
earned the same proud
title.

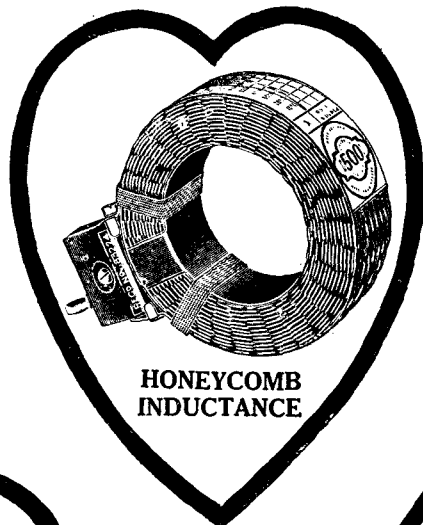

HONEYCOMB
INDUCTANCE

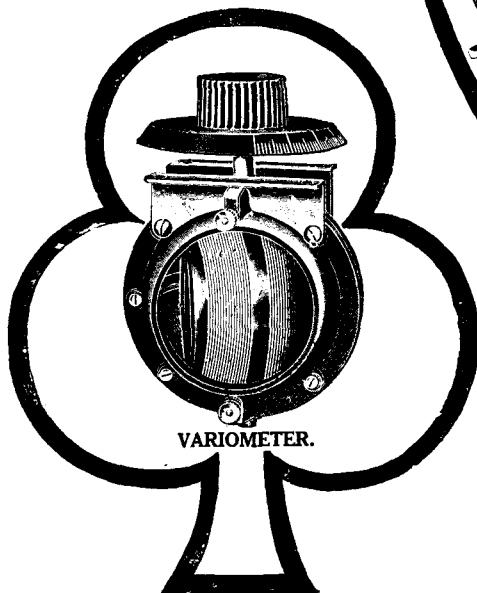

VARIOMETER.

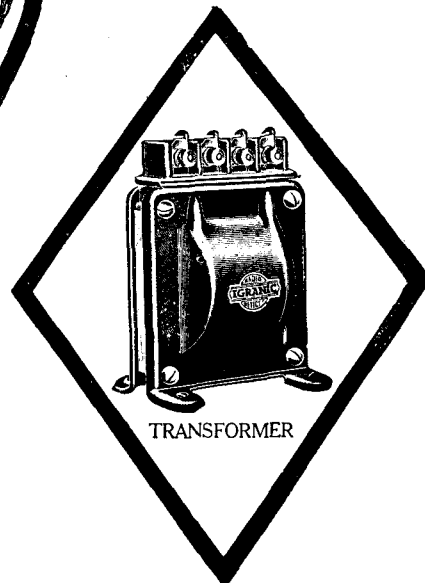

TRANSFORMER



The airmen did not receive
the title from Govern-
ments, or superior officers,
but by popular acclam-
ation.

Similarly the multitude
of wireless users, by de-
manding Igranic devices
in preference to all others,
have emphatically ac-
claimed them "aces."

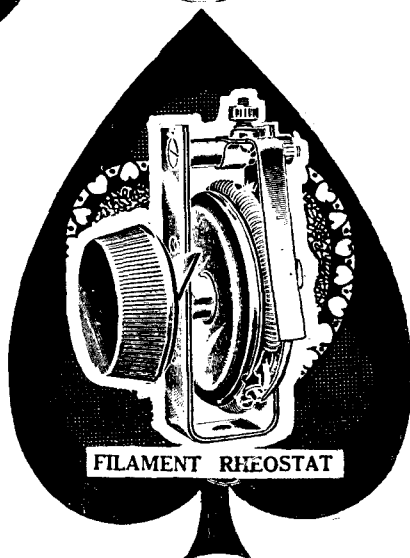

FILAMENT RHEOSTAT

Obtainable from all Dealers.

Write for Lists Z 180.

You cannot always get aces in a card deal, but you always
can in a wireless deal, by simply insisting on "Igranic."

Manchester : 33, Cross Street.
Birmingham : 73-4, Exchange Buildings, New
Street.
Glasgow : 50, Wellington Street.
Cardiff : Western Mail Chambers.
Bradford : 18, Woodview Terrace, Manningham.
**149, Queen Victoria Street,
LONDON.**



Newcastle : 90, Pilgrim Street.
Concessionaire for France and Belgium :
L. MESSINESI,
125, Avenue des Champs, Elysees, PARIS.
94, Chaussée d'Iselles, BRUSSELS.
Works :
Elstow Road, BEDFORD.

The Myers Valve

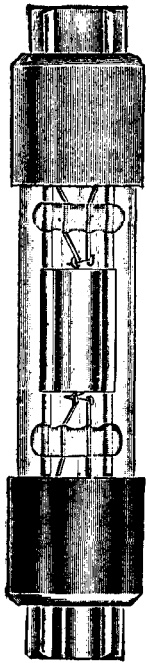

Exact Size.
The Greatest Radio
Invention for the
last decade.

“ the loudest signals that the writer has ever succeeded in getting with a single valve ”

Vide Contributor to “Modern Wireless,” April.

If you want better results than you have ever experienced, replace your valves with the new improved MYERS LOW CAPACITY VALVE—the highest rated valve for high and low frequency amplification.

Universal Type—4 volts '6 amp. 12/6

Dry Battery Type—2½ volts '25 amp. 21/-

Plate Voltage 2 volts—300 volts.

Supplied complete with mounting clips ready to be mounted on your set.

Myers Valves

Sole Distributors: **CUNNINGHAM & MORRISON,**
49, Warwick Road, Earl's Court, London, S.W.5.

AGENTS

LONDON.
THE DULL EMITTER VALVE CO.,
83, Pelham Street, South Kensington, S.W. 7

LIVERPOOL.
APEX ELECTRICAL SUPPLY CO.,
59, Oldhall Street, Liverpool.

NEWCASTLE.
GORDON BAILEY & CO., Consett Chambers,
Pilgrim Street, Newcastle.

MANCHESTER.
R. DAVIES & SONS, Victoria Bolt and Nut
Works, Bilberry Street, Manchester.

GLASGOW.
MILLIGAN'S WIRELESS CO.,
23-25, Renfrew Street, Glasgow.

YOU BUY SAFELY!

When you see our trade mark on a variable condenser.

Renowned manufacturers and experimenters of wide experience prefer “J.B.” Condensers—they are more than an outstanding example of engineering skill. Electrically, “J.B.” Condensers are, in addition, possessive of features which decide that tuning is only efficient if gained by “J.B.” Condensers.

A ratio of 47 to 1 can actually be measured on any “J.B.” '001 taken from stock! Their extremely low minimum and accurate maximum capacity gives a wide tuning range. You can definitely separate different wavelengths—signals do not bunch or crowd—and tune out unwanted stations. The extremely low minimum of “J.B.” Condensers is essential when condenser is used for capacity reaction circuits—and such as the Reinartz.

To our knowledge the electrical losses are the lowest yet recorded—0.05 ohms, which means maximum signal strength and very sharp tuning.

J.B. SUPER ALL-METAL CONDENSER.

This model represents condenser efficiency at its best. Brass End Plates give it the finish of the scientific instrument which it is. Incorporating all the proven “J.B.” mechanical features and generously guaranteed against manufacturing fault for six months. One hole fixing, large top and bottom bush of Grade A, Post Office Ebonite.

A distinctive “J.B.” condenser costing no more than the many unnamed. Sold complete with knob and dial. Spade Terminal Connection provided.

“J.B.” Condensers are British made throughout. We are the manufacturers and we manufacture condensers only. Each instrument is subjected to exhaustive tests before despatch. To benefit by our precision insist upon the genuine “J.B.” Condenser. Look for the trade mark.

Obtainable from all dealers. If any difficulty send direct to the designers and manufacturers:

JACKSON BROS.
(First Floor) — THE Condenser Experts.
8, Poland St., Oxford St., London, W.1.
Phone: Gerrard 6187. Trade Inquiries Invited.

J.B. STANDARD MODEL.

End Plates made by special process ensuring low dielectric losses; owing to close accurate spacing, (dielectric '026), “J.B.” take up much less room under panel; silent, metal plain bearings which do not work slack, are a few of the distinctions obtainable only in the “J.B.” Condensers. One hole fixing. Spade Terminal Connection provided.

Complete with Knob and Dial.	
'001	8/6
'00075	8/
'0005	7/
'0003	5/9
'00025	5/9
'0002	5/-
'0001	4/9
Vernier	4/-

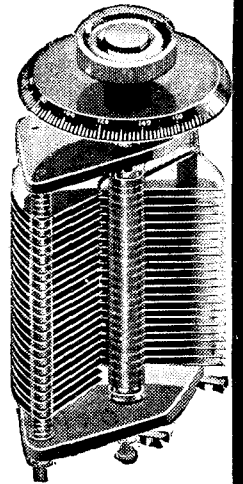

A VERNIER BUILT IN!
For really fine tuning you must use the

J.B. MICRO-DENSER (Prov. Pat. 28028).

Movement to 1/20° possible with readings no one dial. Crude attachments are superceded, and the three plate condenser which doubles dielectric losses is no longer required. This vernier control is built into the instrument, is not an attachment; but is sound engineering practice.

Complete with Knob and Dial.	
'001	11/6
'00075	11/-
'0005	10/-
'0003	8/9
'00025	8/9
'0002	8/-
'0001	7/9

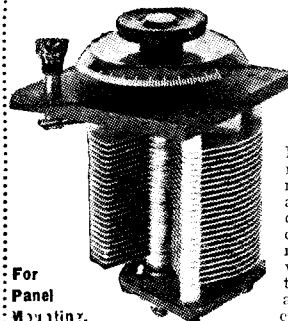

For Panel Mounting.

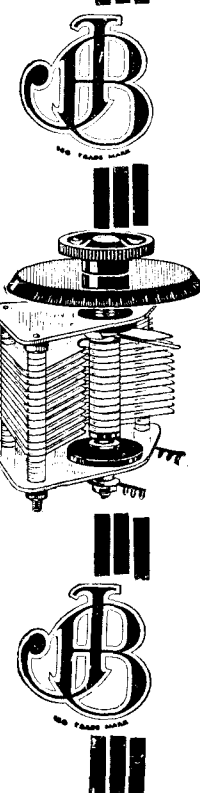

Some Problems of Low-Frequency Amplification

By R. W. HALLOWS, M.A.

Note Magnifiers are often assumed to be pieces of apparatus which are easy to design and handle. This article shows how a number of problems arise.

WE are inclined to regard note magnification in the wireless set as a simple, straightforward business not worthy of a very great deal of attention. It is frequently stated that it is very easy indeed to handle. This is quite true if we are concerned only with the reception of Morse signals, but when we desire to obtain absolute purity in the reception of telephony, together with a large volume of sound, the design and operation of low-frequency amplifying circuits is a problem every bit as intricate as that of high-frequency amplification. The latter appears at first sight to be more difficult to work with on account of the inherent instability of any circuits which have to deal with high frequencies. The bugbear here is, of course, self-oscillation, which is very hard indeed to control satisfactorily. Self-oscillation is of rare occurrence with note magnifiers in which the main problem to be tackled is that of avoiding distortion, or perhaps it would be fairer to say distortion sufficiently bad to cause reception to become unpleasant to the ear. Actually there must always be a certain very small degree of distortion in the valve set even if no note magnification at all is employed. Perfectly true reproduction could be obtained only if the operating portion of every valve's curve was an absolute straight line and if this point could always be so

adjusted that there was no flow of grid current.

So long as we are content with a small volume of sound sufficient to be comfortably audible with the telephones or with the loudspeaker in a very small room, the effects of distortion in a well-designed set will not be apparent. But in wireless, as in everything else, magnification brings up all

sore. Much the same kind of eye-opener frequently comes to the amateur who decides to increase the output of a most satisfactory receiving set, consisting of one or two stages of high-frequency amplification, a rectifier and a note magnifier. Reception with the set as it is is as near perfection as could be desired, but directly a second low-frequency transformer is added

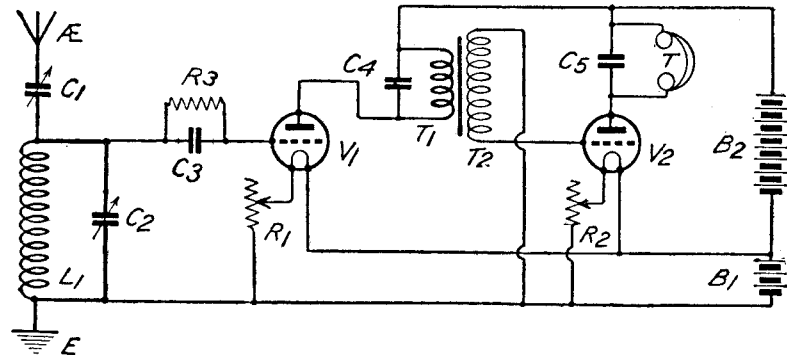

Fig. 1.—A simple low-frequency amplifying circuit.

latent defects so that they positively cry aloud to the senses for notice. A newly-stropped razor blade appears to the naked eye to have a perfectly straight and perfectly smooth edge; but if this same edge is seen under the microscope, it is found to consist in reality of a series of formidable-looking dents and jags whose very appearance is sufficient to make one's chin feel

speech and music become metallic or blurred; there is a raucousness upon certain notes, and items which previously were pleasing now become positively painful to listen to. In such cases, after trying various desperate remedies, the owner of the set usually becomes convinced that it is impossible to obtain a large volume of sound without distortion, or if he has previously used telephones only, he is emphatic in his assertions that really good reception is impossible with the loud speaker. As a matter of fact neither of these conclusions is justified, for though there are limits to loudness combined with purity that can be obtained, there is no reason why the set should not be made capable of filling a large hall without noticeable distortion.

The problem of low-frequency amplification is a really interesting one, and though it is impossible to go fully into it in the limits of one short article, it is felt that a discussion of some of its aspects may

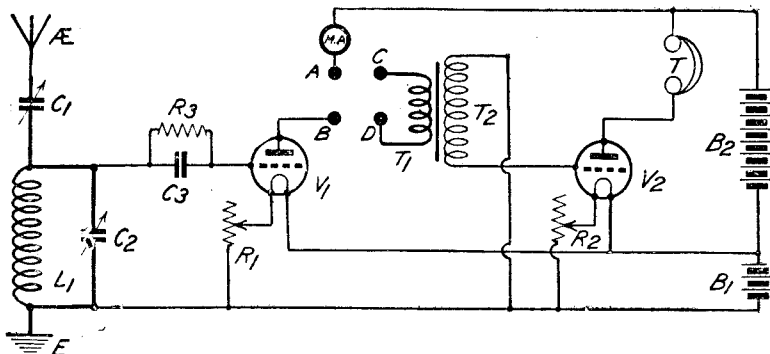

Fig. 2.—A circuit which demonstrates the working of the Fig. 1. circuit

be of interest to readers. One frequently hears the explanation of the working of the simple low-frequency circuit, shown in Fig. 1, given as follows: "Varying potentials upon the grid of V_1 produce changes in the plate current flowing through the transformer primary. These induce in the secondary similar varying currents, and varying potentials stepped up according

current flowing in the plate circuit. Suppose that a strong positive impulse reaches the grid. The plate current endeavours to rise in accordance with the characteristic curve of the valve. It is prevented from doing so by the choke across which there occurs a fall in potential sufficient to keep the current down to its normal level. A negative impulse upon the grid causes a rise

limits. It is impossible actually to reach perfection in this respect, but we can flatten the tuning of a circuit, or, in other words, enable it to offer an impedance of average suitability to a wide band of frequency, by adding resistance. This in the transformer is furnished by the ohmic resistance of the fine wire which goes to make the windings of the primary. The higher this resistance within limits, the smaller will be the peak effect and therefore the less will be the tendency to emphasise unduly any particular frequency. We now see one of the reasons why it is important that the primary would contain a large number of turns. The other reason is that to obtain proper magnification the impedance must be kept as high as is reasonably possible. By using a large number of turns we increase the inductive reactance and the capacity reactance of the transformer, thus bringing up its impedance to a high value.

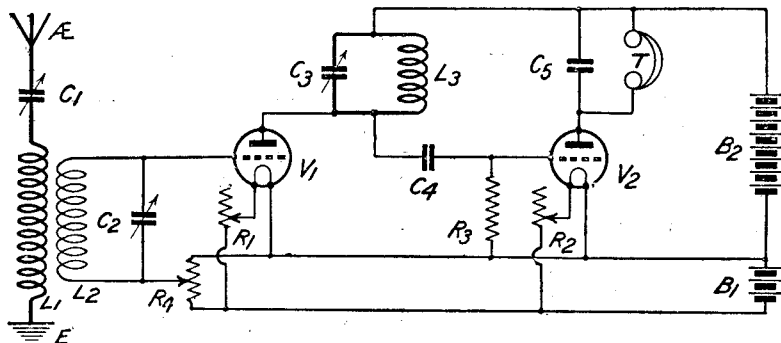

Fig. 3. A circuit using a tuned plate high-frequency valve.

to the turn-ratio of the transformer windings. The condenser across the primary of the transformer serves to by-pass any high-frequency component of the rectifying valve's output." This is all very well as a simple explanation to give beginners a rough idea of what takes place without going at all into theory. Actually it is quite wrong, as a very simple experiment will prove. Make up a circuit such as that shown in Fig. 2. Connect up A C and B D and tune in to a strong signal. It will be found that the pointer of the milliammeter hardly moves during reception, even if one or two high-frequency stages are used in front of the rectifier. Now remove the terminal connections made, and join A straight to B, leaving the tuning as before. The needle of the milliammeter will now record the considerable variations in current that one would expect in view of the changing potentials that are applied to the grid of the valve. We see then that with the transformer primary in circuit, the valve's output does not behave as we should expect it to do from a study of characteristic curves. The current, in fact, remains almost steady in spite of variations of grid potential. This shows us what the truth of the matter is. The transformer primary acts as a choke. Now the effect of inserting a choke or an impedance into the plate circuit is to smooth out the current. At the same time there are potential variations across the impedance. The result is that it is the potential applied to the plate which varies, and not the

potential across the choke (and therefore in that applied to the plate) which prevents the current from falling off. The transformer primary thus acts as a converter, changing plate current variations into voltage variations, which are presented *via* the secondary to the grid of the next valve.

The process would be quite perfect if the impedance were adjusted so as to be infinite to a given frequency. But the impedance of a circuit varies with the frequency. In a low-frequency transformer it would be most undesirable to pro-

A moment's thought will serve to show that the principles involved, in the case of the primary of the low-frequency transformer are exactly the same as those upon which the tuned anode method of coupling high-frequency valves is based. As the two are so closely connected it may be well to turn for a moment to the high-frequency system, for by doing so we may possibly be enabled to arrive at a clearer understanding on the principles of low-frequency amplification. Fig. 3 shows the two valves, coupled by the tuned plate circuit. Here the inductance L_3 forms a radio-frequency choke, and the impedance of the circuit $L_3 C_3$ can be varied by means of the condenser C_3 . Now, on the high-frequency side of the set we are concerned with one frequency only, or if we are receiving telephony with a comparatively narrow band of frequencies. Therefore, by using a coil of suitable size for L_3 and tuning it with a variable condenser, we can make the impedance of this circuit practically infinite to the incoming frequency. This means that the plate circuit current of V_1 is kept quite steady whilst the largest possible changes in voltage take place across the tuned circuit. We see now the reason for the extraordinary efficiency of the tuned plate as compared with other methods of high-frequency coupling, especially for short-wave work. Suppose, for example, we are working upon round about 300 metres. Exactly on this wavelength the frequency is a million per second. We now wish to tune in a trans-

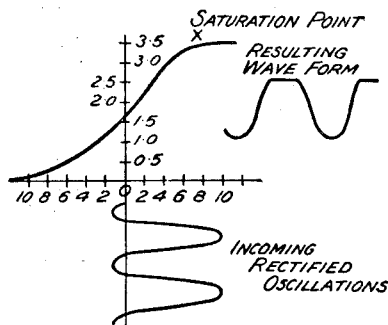

Fig. 4. Showing what happens when valve potentials are wrongly adjusted.

vide an infinite impedance to any one frequency within the range of audibility. If we were to do so we should have a most distressing peak effect and this frequency would be unduly stressed whenever it occurred. As audio frequencies range roughly from 30 to 6,000 cycles a second, we require something which will offer, so far as possible, an equal impedance to any within these

Reasons why EDISWAN VALVES Are Better

Glass.

Glass plays an important part in the construction of a Valve. The *quality* of the glass has a definite bearing upon its span of life—the thickness of the bulb must be regulated to a minute degree of accuracy. One important reason for the superiority of Ediswan Valves is the fact that the whole of the glass required is manufactured at their Ponders End Factory. From the preparing and heating to 1200°C of the mixture which produces the molten glass, to the blowing and final moulding, each stage of the process is carefully supervised. In this way, from the outset, extreme measures are taken to ensure Ediswan efficiency.



PRICES.

"R" - - 12/6

"A.R." - 12/6

"A.R.D.E." 21/-

Dull Emitter,
"A.R.06." 30/-

Latest Dull Emitter.
Current consumption
at 25 volts. '06 of an
ampere.

NOTE.

The safety cap Prov. Pat. which is now fitted to all Ediswan Valves. The filament pins are shorter in length than the plate and grid pins, thus avoiding any chance of making surface contacts with the wrong socket:

Have you had your FREE copy of Illustrated Booklet, "The Thermionic Valve?" If not, send a postcard to-day.
Your Dealer holds stocks to supply you. If not, write us direct, giving his name and address.

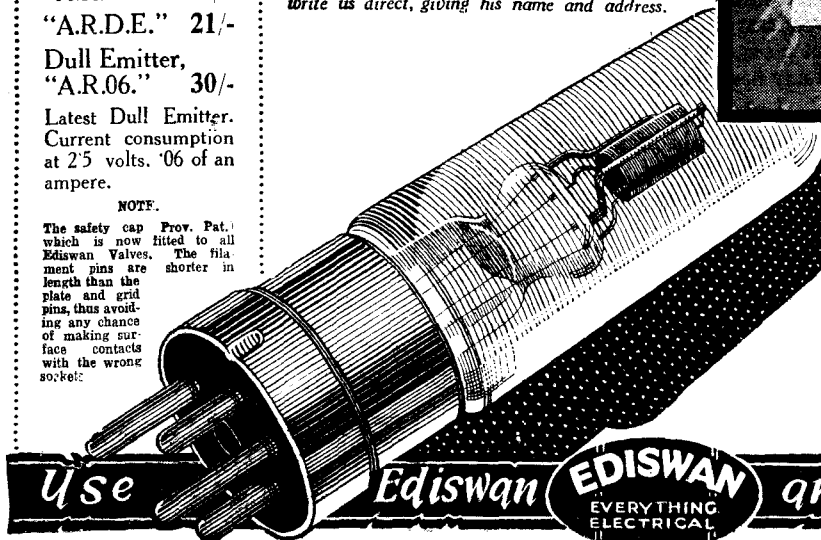

THE EDISON SWAN ELECTRIC CO., LTD.,

Contractors to H.M. Admiralty,
War Office, Royal Air Force.

123/5, Queen Victoria Street, E.C.4.
and 71, Victoria Street, S.W.1.

Branches in all Principal Towns.
Works: Ponders End, Middlesex.

Use

Ediswan



and hear Everything

Buy British

Goods only.

Brown

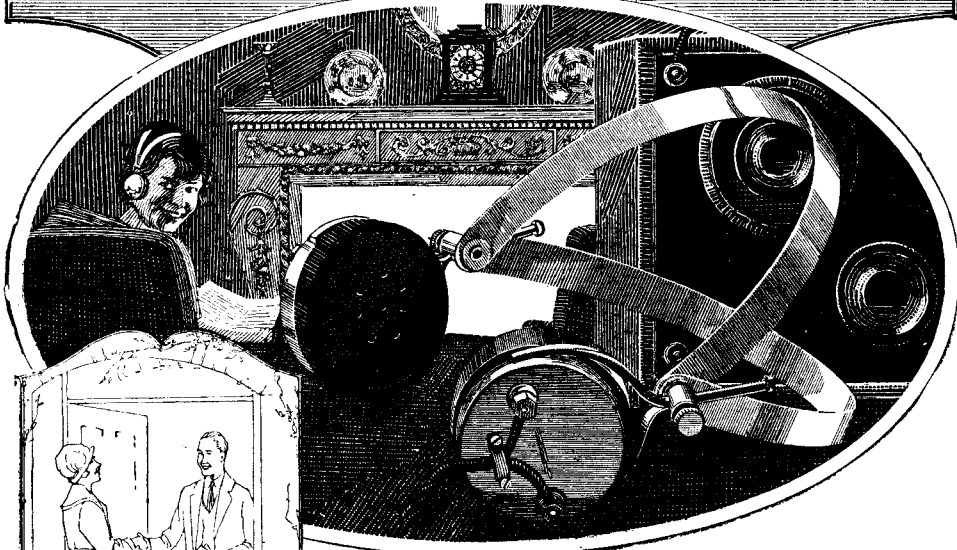

— the spare pair for the Visitor!

WHEN visitors call there are never enough headphones to go round. Why not decide now to keep one or two pairs in reserve and so share your pleasures with those who visit you?

As an inexpensive Headphone, the **Brown F** type Headphone has achieved a wonderful measure of success, and has proved beyond doubt that for sensitiveness and comfort it is ideal for broadcast use. Its weight, including cords, is but 6 ounces, and it can be instantly adjusted to any head—child or grown-up.

Remember, whether you choose the F type at 25/- per pair or the famous A type at 66/- per pair, the quality of material and standard of workmanship is identical. The construction of the A type, with its tuned reed and aluminium cone-shaped diaphragm (spun to the fineness of paper) is of necessity more elaborate. It is a Headphone to be selected for long-distance use or with Crystal Sets giving weak signals.

The D type Headphone is the orthodox flat diaphragm pattern made under typical **BROWN** supervision and sold at a moderate price.

Brown Headphones.

A type 120 ohms ..	58/-	per pair
2000 & 4000 ohms..	62/-	"
8000 ohms ..	66/-	"
D type 120 ohms ..	48/-	per pair
2000 & 4000 ohms..	52/-	"
F type 120 ohms ..	22/6	per pair
4000 ohms ..	25/-	"

From all Dealers or from our Branches at:

19, Mortimer Street, W 1.
15, Moorfields, Liverpool.

S. G. BROWN Ltd., Victoria Road, North Acton, W.3.

Gilbert Ad.—783.

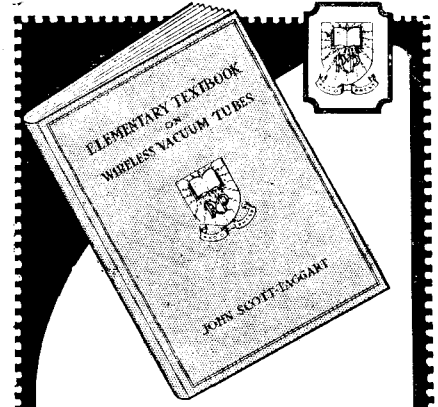

Wireless Vacuum Tubes

— an elementary Text-book written by John Scott-Taggart

F.Inst.P., A.M.I.E.E.

FOR less than the cost of a Valve the keen experimenter can obtain a Text-book—the only one of its kind—on the complete working of the Thermionic Valve. Carefully printed and well bound in full cloth, this book should be on the bookshelf of everyone who is out of the novice stage and who aspires to some sound theoretical knowledge of Radio. Its wide scope, coupled with the fact that its contents are arranged in a progressive and logical order, render it ideal as a work of reference rather than a book that one would attempt to assimilate at a sitting.

With its 250 pages and more than 130 diagrams and illustrations, it represents remarkable value for money and is a book that would be gladly appreciated as a birthday or other gift by any wireless enthusiast.

10/- from all Booksellers, or sent direct by the Publishers (postage 6d.).

Radio Press Ltd
PUBLISHERS OF AUTHORITY WIRELESS LITERATURE
DEVEREUX COURT, STRAND W.C.2.

G.A. 567.

mission on 272 metres. Though there is a difference of only eight metres in the wavelength, there is an increase of 100,000 cycles per second in the frequency. A circuit presenting an almost infinite impedance to a frequency of a million cycles will offer one very much lower to 1,100,000. Hence, if we did not vary the tuning of the circuit $L_3 C_3$ minutely, the voltage changes across it would be small and poor amplification would be obtained. Thanks to the small condenser C_3 we can tune the circuit exactly, and thus give it an impedance precisely suitable to the incoming frequency.

But it has also two other very important functions to perform. In the first place, as the impedance of the transformer is fixed, it must in spite of the resistance of its windings offer a greater impedance to the higher frequencies. Unless something was done to correct this, we should find that all high notes were disproportionately amplified with very unpleasant results. This condenser offers a lower impedance to high-frequencies which are therefore not unduly emphasised. In speaking of note magnification the term "high-frequencies" is perhaps a little misleading. It is used

amount of grid current flowing when the valve to which it is connected is operated with its grid either at zero potential or a certain amount of negative bias is a very minute amount. It will never exact a tiny fraction of a micro-ampere. This introduces further difficulties in the problem of transformer design into which there is not space to enter here. Enough in any case has been said to show the importance of using transformers of really good make. If they are merely put together by rule of thumb with no attention to points such as those which have already been discussed, good results cannot be obtained except by a fluke of the luckiest kind. In transformers as in most other things you get what you pay for.

But it is not the transformers alone that are to be held entirely responsible for low-frequency distortion. The valve itself is a most important factor in the question. One of the most frequent causes of unpleasant reception lies in the adjustment of the valve, so that its working point is not sufficiently far from one of the bends in the characteristic curve. When this happens, oscillations, instead of reaching the plate circuit as they should, unchanged in form but with greater amplitude, are mangled, either the tops or the bottoms of the waves being cut off. This fault may be cured in most cases by paying attention to plate and filament potentials or by providing a grid biasing battery whose voltage must be ascertained by experiment. Sometimes however when the last valve is called upon to deal with oscillations of large amplitude the voltage variations are such that positive half cycles reach saturation point of the valve. Fig. 4 shows what would happen in this case. The saturation point of the valve

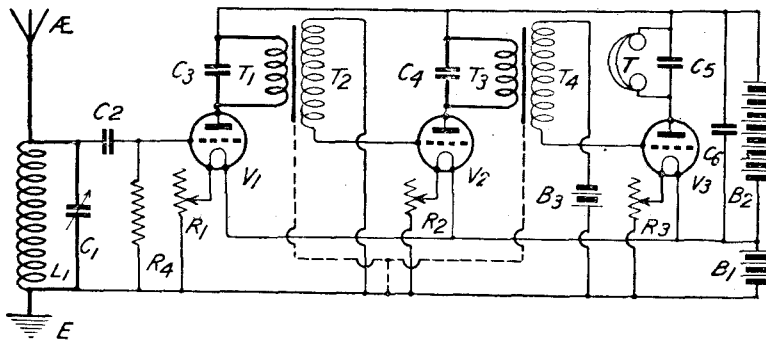

Fig. 5. Two transformer coupled low-frequency valves

When we make use of the resistance capacity method of coupling, the resistance has also a smoothing effect upon the current, but as this effect is to flatten the tuning, the circuit does not respond anything like so exactly to changes in the frequency. It responds as a matter of fact fairly well to frequencies over a large band. For this reason it becomes quite useful for the reception of signals on 1,000 metres or more. If, for example, we are working first of all upon 2,000 metres where the frequency is 150,000 we shall find that a decrease in the frequency of 100,000 cycles per second takes us up to 6,000 metres. Hence we see that though on the short wavelengths 100,000 cycles represent only eight metres, on the higher ones they represent no less than 4,000 metres. Thus a broadly tuned coupling such as a resistance capacity will do excellently on the higher wavelengths, though it will not be at all efficient upon the lower.

To revert to our original theme of low-frequency amplification, the next point to consider is the duty of the condenser which is shunted across the primary of the transformer. With regard to it the stock explanation quoted above is quite correct in one respect: it does serve to bypass the high-frequency component of the rectified current,

here to denote roughly those which lie between 2,500 and 6,000 per second. It would perhaps be more exact to describe them as the upper audio-frequencies. It must be remembered too that the transformer primary forms part of a semi-tuned circuit which contains inductance, resistance, and capacity made up of the joint capacities of the windings and of the shunted condenser. The capacity in shunt serves to bring the natural resonance point of this circuit down below audio-frequency, thus helping to avoid anything like peak effects.

The secondary of the transformer has virtually no load, since the

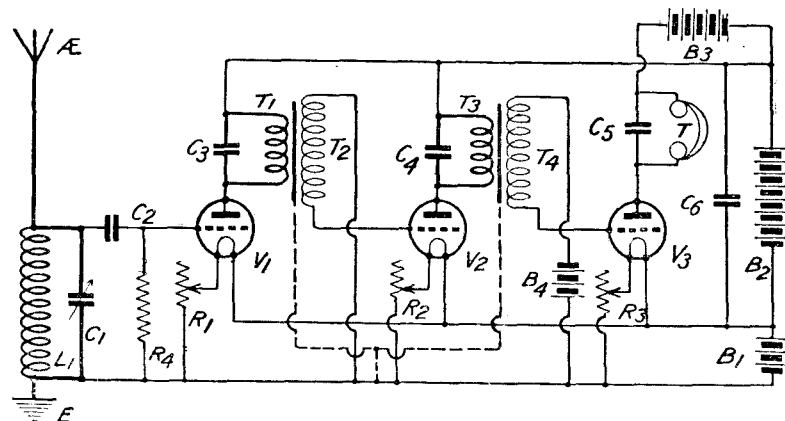

Fig. 6. A similar circuit to fig. 5, but with a power valve as the second magnifier.

is reached when the plate rises to 3.5 milliamperes, the current which flows when the grid is about 6 volts positive. A very strong rectified signal is applied to the grid of the valve. The positive half cycles take the working point of the valve beyond the saturation point; hence the resulting wave formed in the output circuit is something like that shown in the drawing; the tops of the waves have been truncated. Distortion due to saturation occurs usually when an ordinary small valve is used as a second or third note magnifier.

How Distortion Occurs.

The straight portion of its characteristic is not sufficiently long to allow it to deal with incoming oscillations of large amplitude. Something may be done by increasing the filament potential which raises the saturation point, but it is usually advisable to employ a power amplifier rather than a small valve for the purpose. These valves are specially designed to have a very long straight portion in their characteristics. Further, it must be remembered that in any valve the flow of grid current which also produces bad distortion is particularly marked as the grid becomes more and more positive. Hence if the curve of the valve is such that a positive oscillation of large amplitude must take the working point up into the positive half of the curve, a considerable flow of grid current is bound to take place. With the power amplifier one can use a very considerable amount of grid biasing potential, thus keeping the working point low and cutting down the amount of grid current without bringing the working point on to the lower bend.

A First Step.

The first thing to do before attempting to increase the power of the set's output by adding a stage of note magnification, is to make quite sure that as it stands it is reasonably free from distortion and from parasitic noises, for it must be remembered that should these be present any further low-frequency amplification will amplify them enormously. Nothing further should be done in the way of making additions until the user is satisfied that his reception is as near perfection as it is possible for it to be. This can be done by attention to the wiring and to the connections; by controlling the high-frequency side with the smallest possible amount of positive potential, and by paying particular heed to the rectifying valve. It is not at all uncommon to

find that though the high-frequency valves have been made fairly stable by means of proper control, the rectifier shows a tendency to oscillate. This may be found by touching its grid leg with a wet finger. If oscillation is present the characteristic "plock" will be heard in the receivers whenever the finger makes contact. Oscillation at this point is nearly always due to an unsuitable gridleak. It will usually cease when the right value is found. A gridleak, too, may be responsible for a great deal of the parasitic noises for which the high-tension battery is often unjustly blamed. When the same high-tension battery is to be used for both high-frequency valves and note magnifiers it is essential that it shall be shunted with a large condenser.

These things having received attention, the next problem is what form shall the added stage of note magnification take. Figs. 5 to 10

amplifier is employed to use a telephone transformer and a loud-speaker with low-resistance windings. In Fig. 9 we have two note magnifiers, the last of which may be a power amplifier coupled by the resistance capacity method, and Fig. 10 shows a similar arrangement where choke coupling is used.

Which of all these various methods is to be preferred? The commonest are undoubtedly those shown in Figs. 5 and 6. Very good results can be obtained with either of these if the constructor is prepared to take a little trouble in the lay-out of his apparatus. Distortion with these circuits is likely to arise chiefly from the effects of interaction between the two transformers. Before making up the set into cabinet form it is advisable to wire it up roughly upon a board, and to see whether distortion is present when the transformers are placed in the same relationship that they will occupy when in their proposed

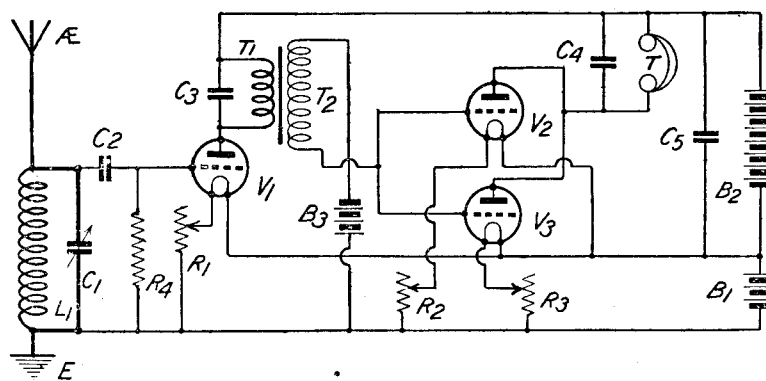

Fig. 7.—Two low-frequency valves used in parallel.

show the various ways in which a large volume of sound may be obtained. In Fig. 5 two ordinary valves, transformer coupled, are used. Fig. 6 is a similar circuit save that the second note magnifying valve is a power amplifier (indicated by the larger circle), extra plate potential for it being provided by means of an additional high-tension battery. In Fig. 7 two ordinary valves are used in parallel, in order that a greater amount of current may be passed to the loud-speaker. Fig. 8 shows a single stage of note magnification, using a power amplifier with additional plate potential. It should be noted that in all diagrams the loud-speaker is shown wired direct into the plate circuit. This is done merely for the sake of the clearness in the drawings. Actually it is desirable while more than one stage of note magnification is used and essential when a power

positions in the cabinet. It should be noted that the coupling between their windings is at its strongest, and the tendency to interaction therefore at its greatest, when they are placed, as shown at A in Fig. 11. The position of B shown in the same figure is also bad and the minimum of interaction is obtained when they are placed, as shown at C, with both their windings and cores at right angles to one another. Even in this position there may be interaction, but this can usually be minimised by connecting the cores together and earthing them, as shown by the dotted lines in Figs. 5 and 6. In Fig. 7 we have a circuit which is not of very much use if it is desired to increase the power of a single small loud-speaker. Actually I can detect no difference whatever in the volume of sound when a second valve in parallel with one note magnifier is switched on to an Amplion Junior.

The **M-L** **TWIN-COIL INTER-VALVE TRANSFORMER**

makes all the difference

It can be relied upon to function perfectly under all ordinary conditions of working. Its proved superiority gives greater amplification at greater range than other makes, with an entire absence of distortion. Special attention has been given to insulation, resistance between windings is high and is tested at 600 volts. There is no danger of burning out when high voltages are used on the anode. Dust and damp proof. Primary to secondary ratio 1-4. Ready for mounting. The following is an extract from a letter we have received from an Amateur enthusiast:

"It is the best Transformer I have tried so far and I have had considerable experience since 1917. I am delighted with the results I am now getting, thanks to you."

Price 30/-

Carriage paid.
Ready for mounting

We invite applications from traders for terms



THE M-L ANODE CONVERTER:
A reliable substitute for the high tension battery. Specially useful for power amplifier work. Results in perfectly smooth reception. Supplied in standard voltage ranges.

Write for full particulars:

The M-L MAGNETO Synd. Ltd.

Wireless Dept., **COVENTRY.**

Max-amp

L.F. Transformer

—more than 40,000 of these splendid Transformers are in daily use

TO have sold more than 40,000 Max-Amp Transformers entirely by post, or by our own Branches and not by Agents or Dealers, is a record of which we are proud. Obviously when a man can buy other types of Transformers locally, and yet prefers to go to the trouble of sending his order to us by post, he must realise that he is getting

a Transformer quite out of the ordinary. And the Max-Amp is an exceptionally good Transformer—in fact, it has been tested before independent experts in comparison with all the higher priced instruments, and we have yet to find one which will beat it either for volume or tone. You might pay very much more than 18/6, but you won't get a better instrument.

Tested to 500 volts, primary winding silk covered, stalloil insulated core, external winding of protective green cord. Sold in neat carton and fully guaranteed by:

18/6

PETO-SCOTT CO., LTD.,
Head Office: 64, High Holborn W.C.1. Branches in London, Cardiff, Liverpool & Plymouth.



G.A. 786

Ask Your Dealer for

RADION HIGH FREQUENCY VALVES

Filament Volts	-	-	-	3.5 to 4
„ Amps	-	-	-	.25
Anode Volts	-	-	-	30 to 90

Each valve is tested before leaving the works and the guaranteed minimum radiation shown on the box.

Manufacturers:

RADIONS, Ltd., BOLLINGTON, Near **MACCLESFIELD.**



—and the night shall be filled with music.”

—And the night shall be filled with music
And the cares that infest the day
Shall fold their tents like the Arabs,
And as silently steal away.”

YES! Only the home possessing a Radio Receiver is fully equipped to charm away all the little cares and worries which tend often to make life a burden. For the invalid, for the stay-at-home, for the housewife, for the kiddies, for the head of the family, there is one undeniable tonic—Broadcasting.

But to obtain the maximum enjoyment from Broadcasting, only reliable apparatus should be used. The Valves, for instance, must be ready at the snap of a switch or the twist of a rheostat to give you faithful and unvarying service for many, many months.

One of the recognised strong points of the Cossor Valve—appealing to the Experimenter and Broadcast Listener alike—is its extremely long life. This is entirely due to the filament which, arched like a bridge, is entirely self-supporting.

Obviously any Valve with a long straight filament, constantly stretching and contracting as current is passed through it, must eventually either sag or fracture. If the former, then the filament touches the Grid, and the Valve is quite useless, and in the latter the filament cannot light.

When buying your first Valve or replacing an existing one make sure you choose a Cossor. In spite of its innumerable advantages, it costs no more than an ordinary Valve.

Type:	
P.1. for Detector and L.F. use	12/6
P.2. (With red top) for H.F. use	12/6

A. G. Cossor, Ltd., Highbury Grove, London, N.5.

Sold by all
Wireless
Dealers.

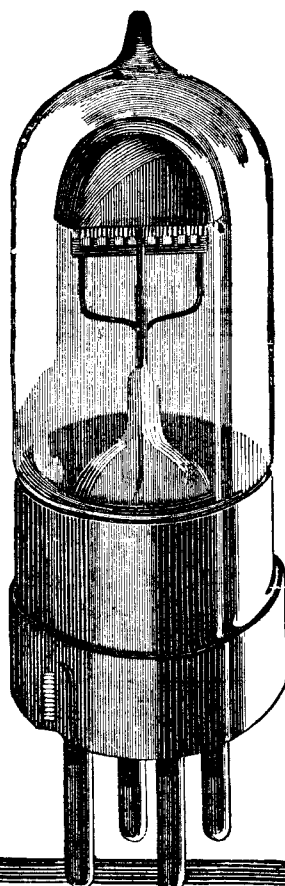

Gilbert P. d. 774.

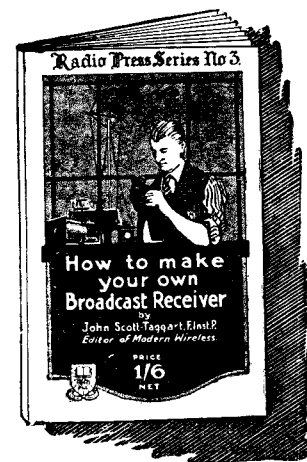

Splendid Broadcast Sets made without special skill.

IT is not often easy to condense into a single constructional Article all the details necessary for a complete beginner to build up a Broadcast Receiver. Naturally the space in a Magazine like MODERN WIRELESS is rather limited. Therefore, if you are looking for a first-class book on how to build good Crystal Sets, you cannot do better than get this one. "How to make your own Broadcast Receiver" is written by John Scott-Taggart, F.Inst.P. (Editor of MODERN WIRELESS and Wireless Weekly). It deals with the whole subject from A to Z, and if you are at all handy with your fingers, you can easily build up an excellent Receiver at small cost.

Remember you do not need to know a single thing about Radio—it's all in the book, and you can learn it in a few hours.

1/6 Get a copy TO-DAY.

From all Booksellers, or 1/8 post free.
RADIO PRESS, LTD.
DEVEREUX COURT, STRAND, W.C. 2.

Radio Press Wireless Library, No. 3.

The circuit is, however, useful when it is desired to operate simultaneously two or more loud-speakers placed in different parts of the room, for it does supply sufficient current to meet their requirements.

A Good Circuit

When a transformer is to be used I think that by far the best circuit is that shown in Fig. 8, which employs a power valve such as the Mullard P.A. or the M.O. LS 5 as the D note magnifier. The fact that a power amplifier with high anode voltage is used makes it possible to obtain a considerable volume of sound with even one stage of audio frequency amplification. Further, since there is but one transformer the likelihood of distortion is greatly diminished and there will of course be no interaction. With a power valve it is usually necessary to furnish a grid biasing potential of quite respectable size. The exact E.M.F. will of course depend upon the anode potential used; as a rule it will be between 6 and 15 volts negative. In Fig. 9 we have a circuit which has been for some reason very little used in this country. It consists of two note magnifiers coupled by the resistance-capacity method. Valve for valve it is not so efficient as the transformer method; this we should naturally expect owing to the fact that the effect of the resistance is to produce a smaller reduction in current fluctuation than the

about the same volume of sound as a two stage amplifier with transformers. It is a very pleasant piece of apparatus to use, since once the current adjustments have been found they never vary and it remains perfectly stable. A suitable value for the anode resistances is about 80,000 ohms, but it is an advantage where three valves are

2-megohm leaks are used it is sometimes found that the middle valve of a trio becomes rather unstable and shows at times a tendency to oscillate. Also there may be a ticking noise occurring at regular intervals which indicates that one of the valves is working up periodically to the oscillating point. Both continuous oscilla-

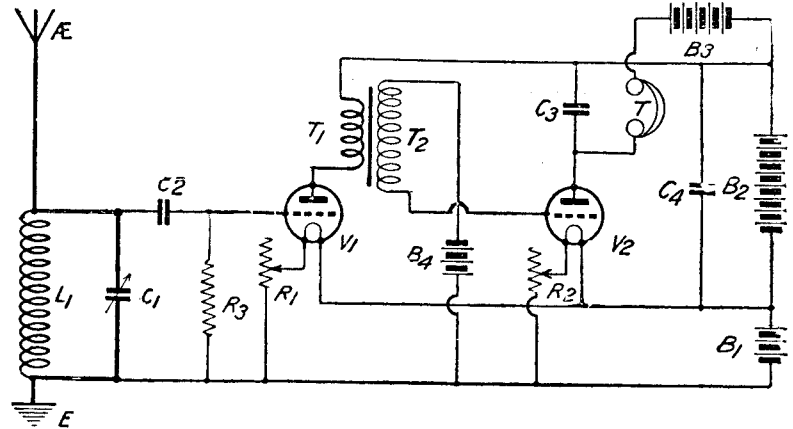

Fig. 8.—A single stage of low-frequency amplification using a power valve.

used to fit variable resistances so that each can be adjusted individually. The capacity of the coupling condensers may be .01 μ F. Larger condensers may be used of desired, but I have always found these capacities excellent for the purpose. The only difficulty that there is about this circuit lies in the tendency of the valves to rectify partially unless they are

tions and ticking can be cured by the use of a variable gridleak. There are two points of great importance in using this circuit. The first is that the high tension battery must be shunted by a 2 μ F condenser, the second that the low potential side of the secondary circuit, if one is used, must be earthed.

Fig. 10 shows the choke coupled low-frequency circuit about which a good deal has been heard recently. Though I cannot claim to have had any long practical experience on this form of coupling I have always found it very good, and where two or more note magnifying valves are required it seems to run the resistance-capacity method very close. The degree of amplification obtained is rather greater valve for valve, but there may be certain losses in purity unless the impedance is very nicely adjusted.

We have seen that there is a good deal more in low-frequency amplification than a casual observer might imagine. In this article it has been possible of course only to touch upon the fringe of the subject. Any reader who cares to study the question of transformers will find that he has entered upon a most interesting field. Of the practical side of the question the conclusions to which we come are as follows:—

1. Before any note magnification can be added successfully the high-frequency and rectifying parts of

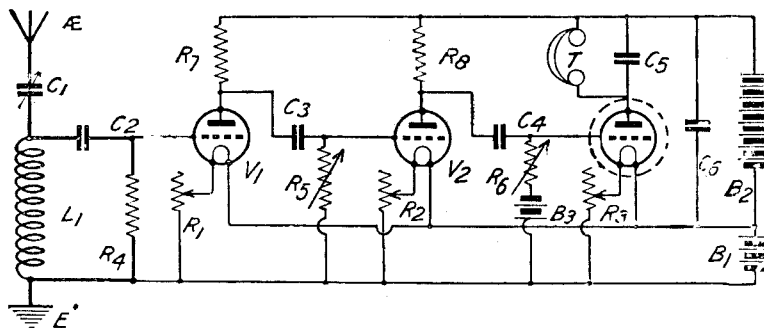

Fig. 9.—Two resistance-coupled amplifying valves.

primary of the transformer; it follows that the voltage variations across the resistance will not be so great. Actually the efficiency is about 70 per cent. of that of the transformer system; but one great advantage of resistance-capacity coupling is that three or more low-frequency valves can be used in series without there being any distortion. I have a three valve resistance-capacity coupled note magnifying unit which gives

very carefully adjusted. This tendency may be corrected by means of the filament rheostats and by regulating the anode voltage; but it is as well to provide variable gridleaks which enable the unit to be adjusted to a nicety. If fixed gridleaks are used they should be of comparatively small resistance. One megohm is the largest size that should be tried and better results will probably be obtained with leaks of half this value or less. If

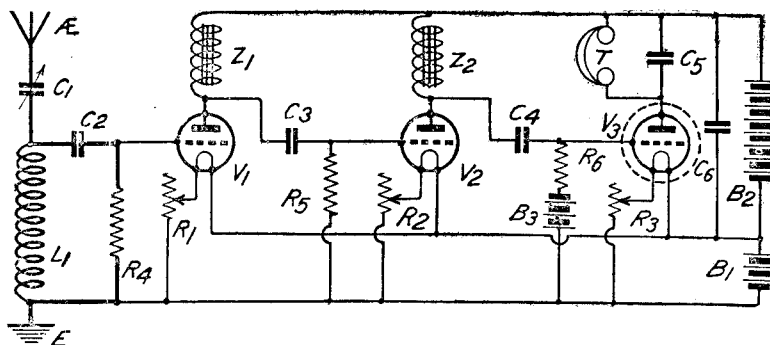

Fig. 10. A choke coupled low-frequency circuit.

the set must function without parasitic noises and there must be no uncontrolled oscillation.

2. If sufficient volume of sound from the loud speaker is required to fill a sitting-room of average size one stage of low-frequency amplification using a power valve will usually suffice.

3. Where transformers are used they must be instruments of good quality, well designed and well made.

4. To obtain a greater volume of sound than that referred to in (2), the best methods are probably the resistance capacity coupling or the choke coupling. Three stages of the former or two of the latter will usually suffice.

5. For any stage which has to deal with large grid voltage variations it is best to use a power valve owing to the long straight portion of its characteristic curve.

May I add one word about transformers. The points to be looked for in a good low-frequency transformer are these: In the first place it should be heavy, with a core of large cross section to provide a good path for the magnetic field. The core should be made up of very thin laminations each of which should be well insulated from its neighbours on either side. The laminated and insulated core prevents to a great extent the setting up of eddy currents. In this connection it should be noted that it is not a point of good design to clamp the side members of the frame together by means of bolts passing through holes in the core; it is of little use to insulate the laminations from one another if you connect them electrically at the corners by such bolts. Next the windings should contain a large quantity of wire. The step-up ratio is not a matter of great importance; in fact, so far as I can see it makes very little difference indeed to the performances of the transformer. I have tried recently a set of four transformers of the

same make wound 1 to 1, 2 to 1, 3 to 1 and 4 to 1. If there is anything to choose between them the first two are possibly a trifle better than those with the larger ratios. The important thing is to have plenty of turns on the primary. Lastly the insulation resistance is a matter of very great importance. A well wound transformer should show a resistance of from 200

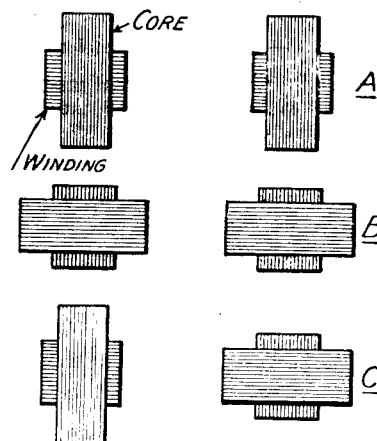

Fig. 11. Different relative positions of transformers.

megohms upwards at least between winding and winding or between winding and core. This can be tested by means of a megger. Should the insulation be poor the transformer will always be noisy, and conversely the better it is the freer will be the instrument from those cracklings and sizzlings which so often ruin reception.

Single Valve Long-Distance Reception

To the Editor of MODERN WIRELESS.

SIR,—No doubt it will be interesting to you and your readers to hear of the results I am getting on a single valve set with

reaction made from instructions given in MODERN WIRELESS and *Wireless Weekly*. It was said that this set was unsuitable for broadcast reception, but whilst writing I am listening to a concert from London 2LO, 2,100 miles away. This is not a freak, as during our voyage from England to Italy and Alexandria, the captain, the officers of the ship, and myself have daily listened to the English broadcasting stations.

London and Cardiff, and sometimes Glasgow, are the stations we hear best, at port here in Alexandria where we are surrounded by ships, and plenty of iron buildings, and with the 5KW station close by. Under these adverse conditions I picked up the following from Cardiff on December 5th with plenty of interference and atmospherics.

21.30.—News items.

21.35.—Results of matches. A few names of towns and scores were discernible.

21.42—21.52.—A few words audible, including—"tomorrow-night" and "very good."

21.53.—Music and singing.

The following on December 7th.

20.50—21.05.—Opera songs.

21.10.—The words "Ladies and gentlemen"—followed by singing.

21.20.—Somebody speaking about "inductance"; the words "most important" were very clear.

21.40.—Somebody speaking about milk. The words "any more—all I ask you to remember" were quite distinct.

I think the above concert was given by all the stations, and I noticed, on the evenings of December 26 and 27, while passing between Candia and Milos, 100 miles off Athens, that the Savoy dance music was given by all stations, and they were still sending after 11.30, their usual closing-down time. I believe this to be the first time the B.B.C. stations have been heard in Greece.

I have had wonderful results on W/T stations also, W.I.I. (Belmont, N.J., U.S.A.) and W.Q.L. (Independence, Kans., U.S.A.) coming in very well at over 4,000 miles distance, and the S.O.S. of an American ship in the Black Sea came in the day before we arrived here.

Yours faithfully,

(Signed) L. SELAVOUNOS.
W.O., S.S. *Eugenia*.

Alexandria.

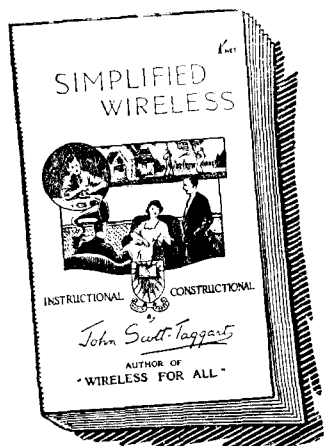

Shows you how a Crystal Set actually works

ONE of the most fascinating features of Wireless lies in its utter simplicity. In "Simplified Wireless," for instance, the whole principles are laid bare in such simple language that boys of all ages can readily understand them.

A very interesting course of elementary electricity is given, and full details are given for commencing at the very beginning, and building up a workable Receiver more or less out of material found about the home. "Simplified Wireless" is a thoroughly readable book, and one you'll enjoy reading immensely.

Read this interesting List of Contents

Some General Remarks regarding Wireless—The Telephone Receiver Transformers—Air-core and Iron-core Transformers—Step-up and Step-down Transformers—Inductances—condensers—Frequency and Wavelength—The Aerial Circuit of a Wireless Receiver—The Use of a Variable Condenser when Tuning—The Crystal Detector—A Receiver Using a Variable Condenser—Loose-coupled Circuits—Notes on the Erection of Aerials—Frame Aerials—Loud Speakers—How to Make a Simple Broadcast Receiver—Operation of the Receiver—The Variable Inductances—Some simple forms of Crystal Detector—The Telephone Condenser—The Complete Arrangement of the Apparatus—Operation of the Circuit.

1/-

From all Booksellers, or 1/2 post free
RADIO PRESS, LTD.,
DEVEREUX COURT, STRAND, W.C.2.

Radio Press Wireless Library, No. 2.

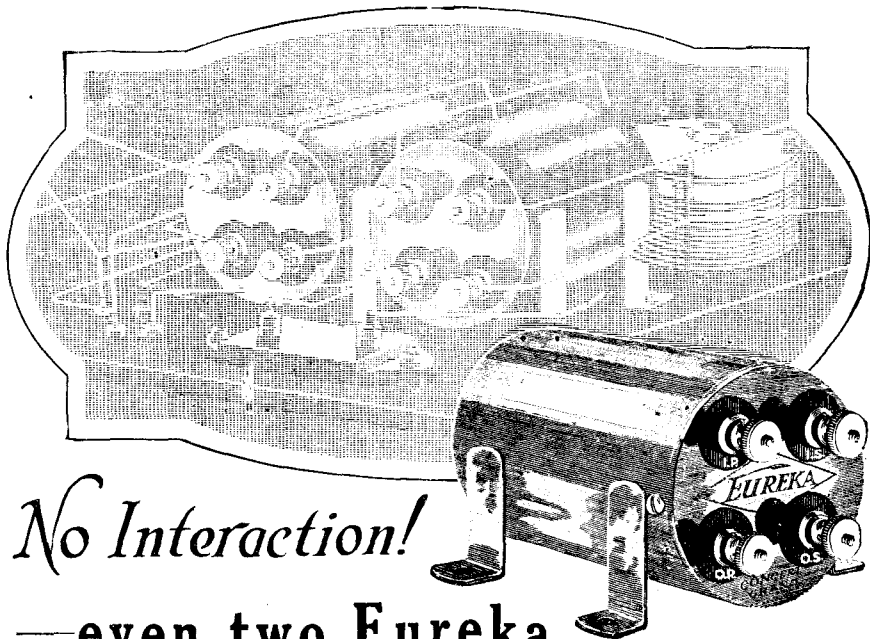

No Interaction!
—even two Eureka Transformers touching cannot cause howling!

FOR the S.T. 100 and any Set requiring two Low Frequency transformers, the big difficulty hitherto has been the correct position of the transformers.

It is recognised that in a reflex circuit particularly, the slightest interaction between the two transformers will cause howling and other noises. When ordinary transformers are used it is necessary to space them well apart and to place the cores at right angles to each other. This invariably means longer connection wires and inefficiency. Now, however, the Eureka offers complete emancipation from interaction even with the transformers touching.

This striking example of efficiency is typical of the superior design

and construction of the Eureka. Not only does it give immense amplification (the Concert Grand Model will give a volume equal to that from two ordinary L.F. Transformers), but its tone is utterly free from distortion and noises.

The small additional cost of the Eureka Transformer (necessitated by the fact that almost twice as much wire is used) is amply recompensed by the vastly superior results you will obtain. See that your next Transformer is a Eureka and be assured of perfect reception.

Made in two types :

Concert Grand 30/-. No. 2 (For second stage) 22/6.

Sold by all Dealers and Manufactured only by

ELECTRIC APPLIANCES Co., Ltd.,

7 and 8, Fisher Street, London, W.C.1.

Branches—Leeds : 1, Oxford Place. Manchester : 9, St. James Square. Scottish Agents: Blackie, Fuller & Russell Ltd., 30, Gordon Street, Glasgow.



Gilbert Ad. 775.

In replying to advertisers, use COUPON on last page



is essentially light and careless. The spirit of it is lost if one has to go abroad to find it.

Now, in these evenings when the weather is still treacherous, a little music and entertainment are best of all at home. Do not spoil your pleasure by an inferior loud-speaker.

The new Volutone Loud Speaker gives a really large volume of sound, combined with a richness of tone, that is so essential for good music. In price it compares favourably with any other large loud-speaker on the market. Wound to 2,000 ohms; adjustable diaphragm.

Price £4 : 10 : 0

Fellows Magneto Co., Ltd.

Park Royal, N.W. 10. Phone: Willesden 1560-1



**FELLOWS
VOLUTONE
LOUD SPEAKER**

E.P.S. 62.

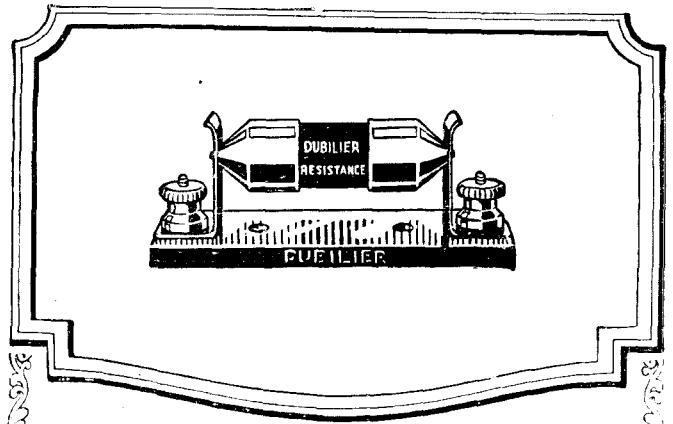

Anode Resistances.

The use of Resistances and Condensers in the place of Transformers is a method of amplifying Wireless signals which offers several advantages, particularly on the longer wavelengths.

Firstly, there is a saving in outlay. Secondly, there is an absence of distortion which has made this method of amplifying a favourite among enthusiasts.

But—there is always a “but”—the Resistances must have certain important qualities.

They must remain **CONSTANT** in value, and they must carry normal loads for prolonged periods **WITHOUT OVERHEATING**.

These problems were the subject of long experiment in our laboratories, and we finally placed on the market Anode Resistances in nine standard values of 20,000, 30,000, 40,000, 50,000, 60,000, 70,000, 80,000, 90,000 and 100,000 ohms.

Each Resistance is tested during manufacture on a load of 200 volts D.C., and has to pass such stringent tests with honours before it is offered to you.

It is supplied complete with holder as illustrated, and costs only

5/6.

*THE DUBILIER CONDENSER CO. (1921), LTD.,
Goldhawk Rd., Shepherd's Bush, London, W.12.
Hammersmith 1034.*

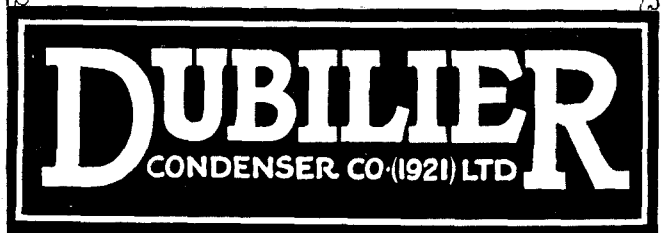

Readers' Experiences with the "M. W." Modifications of the Grebe C.R. 13.

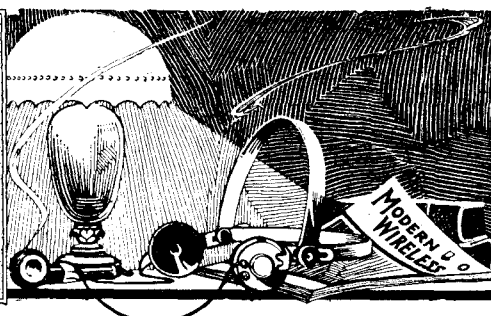

To the Editor of MODERN WIRELESS.

SIR,—I trust you will forgive me for taking the liberty of writing about my experiment with a set similar to that described in MODERN WIRELESS under "Further experiments in high-frequency amplification." I had it on trial after the broadcasting hours during the night of the 29th to 30th March. After having been listening to an unknown Paris station (about 1,200m. wavelength), I tried the general tuning of some Morse stations, and I got very quickly the impression that the set was very sensitive. The coil holder manipulation was very tricky, but I soon overcame this difficulty. The only similar coils I had in hand were two "Igranic" 75, and I took them for the grids. These were tuned by two square law Sterling condensers .00025 with vernier. The two anode coils were respectively Igranic 100 and 150, and the aerial coil was No. 2 Peto Scott with a Polar .0005 in parallel. The valves in use were three V.21.

At two o'clock (30th March) I decided to begin a systematical work and put the Polar at O, adjusting the two grid condensers and coil holders. I soon realised that the aerial coil tuning was *not sharp* at all. At 20° on the Polar and with the right tuning of the grid coils I heard a voice and so loud that I thought I had tuned in a London amateur. But immediately the accent surprised me, and I heard the call-sign W?? (W B D.)* Boston studio of the Westinghouse Electric Co. I may mention here that I am Swiss, and six months ago did not know a word of English. That is the reason why I could not remember this call sign. The tuning of the grid was sharp like a razor and the verniers were quite indispensable. The slightest detuning brought the set into self-oscillation, but with exact tuning the set was as stable and silent as a crystal receiver. Atmospheric were non-existent, there were no Morse stations, but only a few

oscillating experimenters, which did not disturb me at all, because the set was extraordinarily stable and selective. I was listening 1½ hours and heard the "good-bye" at 10.52 American time. The two last items were given by a quartet (instrumental). I heard many times the call sign, but I could not realise what these letters were in French. If you could tell me the call sign of the Boston Studio of the Westinghouse Co., I shall be much obliged to you.

Hoping this will interest you, and with congratulations for your interesting articles in MODERN WIRELESS, I remain,

Yours faithfully,

RENE TOLIK.

London.

*EDITOR'S NOTE.—This would be WBZ (pronounced WBZee), the Westinghouse station near Boston.

To the Editor of MODERN WIRELESS.

SIR,—I was much interested in the modification of the Grebe C.R. 13 circuit described in your recent issue, and have made some preliminary trials of a I-V-I circuit on these lines with interesting results.

A home-made unit experimental set was employed.

The grid circuit of the first valve was tuned with a variable inductance of a design which I have provisionally protected, but which need not necessarily have been of this form. It consists of three inductance coils, two fixed, which are widely separated in parallel planes, and the third co-axially movable between them and of slightly smaller outside diameter so that it can enter completely inside either of the fixed coils. It is traversed by a quick-thread screw provided with an ebonite knob. The three coils are connected in series, one fixed, one being wound in conjunction, and the other in opposition to the moving coil. A variometer effect is thus obtained, and this construction enables other inductances to be coupled as loosely or tightly as desired.

In this particular instance the variometer was wound with 16 S.W.G. bare copper wire spaced $\frac{1}{8}$ in. longitudinally and radially. An "aperiodic" aerial inductance of 14 S.W.G. tinned copper was wound over the 7-turn fixed coil. It consisted of a single layer of 13 turns, about 6 in. diameter, and spaced $\frac{1}{8}$ in. air-space. The size was chosen quite arbitrarily, a length of wire from the "junk-box" being wound on until it was all used up. A fixed series condenser of .0001 μ F was used, as my aerial is a short twin tee having considerable capacity to parallel roofs below it.

The secondary variometer was shunted by a .0005 μ F "Polar" condenser to bring it up to the broadcast band, as it was wound for lower wavelengths. This was not used for actual tuning, being merely adjusted to the approximate capacity required.

The rectifier grid was tuned by a duo-lateral plug-in coil shunted by a .0002 vane-type variable condenser, on the case of which it was mounted. The wire used in this and the anode inductance was 20 S.W.G. D.C.C. with only a few touches of celluloid cement at the exposed crossings to bind it. A fine-thread screw adjustment was used to alter the coupling of these coils, as it was found extremely critical.

The "earth" end of the aerial inductance was connected to the arm of a S.P. change-over switch, which enabled it to be connected to either a water-pipe earth or a buried earth at will.

A number of tests were made without the coupled aerial connection, *i.e.*, with aerial and earth connected direct across the variometer, with the .0001 condenser in series with the aerial. Very poor reception was obtained with this and considerable jamming from adjacent broadcast wavelengths and morse. With the closed-circuit coupling the volume was greatly increased, and, as might be



SCREWED JACK,



TWO-WAY PLUG.

PLUG AND JACK .. 3/- pair

Mansbridge Condensers

1 and 2 mfd., 2/6 each

Chokes, 1,000, 600, 100 ohms, 1/- each

Receivers, Loud Speakers and Transformers Rewound

A. ROBERTS & CO., 42, Bedford Hill, S.W.12



100% EFFICIENCY H.T. BATTERY

See editorial report, April issue, page 640, also page 657. Giant Dry Cells. Wt. 5 ozs., 4 doz. Limited number 60 volt box type, 17/6. Carriage extra any quantities. Direct from maker, saving 50 per cent; full details free. Sample cell fd. Orders in rotation, owing to large demand. No discounts.

Sole Maker,

FINCHETT (C.A.), OLD ARMOURY, OSWESTRY.

You can conjure with your set if you use the **HUMPHRYS VALVE ADAPTER** (Patents pending)

An Improved Means of Experiment.

By its valves can be changed in a few seconds from H.F. to L.F. or vice versa, or from either to Detector. By it, sets may be equipped with Tuned Anode, Reaction, Stabilising devices, Grid Bias, Etc., without changing a connection or lifting a panel. Demonstrations Daily. Price per Adapter 3/3 Post Free. (Two required for Tuned Anode.)



W. E. H. HUMPHRYS,
14, Clifford St., Bond Street, London, W.1.
Condensers Calibrated. Sets and components the pick of experts always on view, new and secondhand. Burndept Ultra IV's from £20, Ethophone V's from £22.10.0. Marconi V's from £15. Voice Amplifiers from £12. Elwell Multi-valve sets at special prices. Phone: Regent 376a.

Fix your crystalin



GOLD SEAL PLASTIC METAL
the best contact possible, and get louder and clearer signals. Contains no mercury. Of all Wireless Stores Enough for **6D.** per packet. 3 cups. Wholesale enquiries (or sample packet 6d.) to: **8, LEVY, 53, Ben Jonson Rd. London, E.1**

WIRELESS FOR THE AMATEUR.

By **JOSEPH ROUSSEL.**

Authorised translation by H. B. GRYLLS. Demy 8vo, 14/- net. **ELECTRICITY.**—Not only has the book been very ably translated by Mr. H. B. Grylls, but the additions that have been made add very considerably to its value. From the practical standpoint the book is filled with interesting details. "To those amateurs whose workshop knowledge and experience is small, the chapter on materials and tools would enable them to proceed with their set building in the best possible way. The added chapters on short-wave receivers and short-wave transmitters are very well written and contain very sound information. Throughout the book the diagrams are clear and ample to the text. . . . It is a book we should strongly recommend to all those who wish to go really deeper into wireless matters than the average listener-in, as no other book we know of contains such a wealth of practical advice and information."

London: **CONSTABLE & CO., LTD.**
10-12, Orange Street, W.C.2.

expected, the set was extremely selective. I do not remember getting such purity of reception by any other circuit, combined with such selectivity as was then obtained. Even the strong morse interference which we get here on a plain tuned-anode circuit I-V-I with moderate reaction, was reduced to negligible proportions. Tuning of the H.F. grid was exceedingly critical, and that of the rectifier grid rather less so. The best results were got with an H.F. anode coil about 20 turns larger than the grid coil. Larger coils were tried, with somewhat increased volume, but a marked tendency towards self-oscillation. Fair reception was got with an anode coil as low as 15 turns of bare well-spaced wire, but the volume increased noticeably with each succeeding increase of this inductance.

The most remarkable point was observed in changing over the earth switch. Signals increased fully 20 per cent. in strength with the earth entirely disconnected, and were slightly better with the filament-end of the secondary earthed than without. Hand-capacity effects were marked in all the H.F. components. There can be no doubt that the wiring of the set was badly arranged in some respects, and the units were too much crowded together, while the fact of getting the best signals with the earth switch open shows a large leakage capacity from the aerial tuner to earth. I think the insulation throughout was good, but no special tests were made to determine this.

The setting of the H.F. rheostat was critical, but when adjusted it was possible to work with the potentiometer fully negative. When the voltage across the H.F. filament was increased from 4.3 to 4.4 volts, a slightly positive setting of the potentiometer was required to damp out oscillation, and this setting also became critical. Altogether, the circuit, as arranged, would be much too sensitive for any but experienced hands, but when adjusted it was quite stable over the whole broadcast wave-band, and practically only two controls were necessary for changes of wavelength, viz., the variometer and the H.F. anode condenser, although the coupling of the anode and grid coils required a minute change for maximum signals.

It is well worth further experiment.

Yours faithfully,
JOHN A. SANG.

Belfast.

To the Editor of MODERN WIRELESS.

SIR, — I was very interested in your article in the February number of MODERN WIRELESS, especially as you mention the Grebe C.R.13.

I have a Grebe C.R.5 detector here coupled to a home-made 2-stage L.F. amplifier, and have had very successful results with this on long-distance reception of telephony and broadcasting.

This set is efficient on all wavelengths from 150-3,000 metres and is highly selective combined with ease of tuning.

I have received the following U.S. stations, besides a number of U.S. amateurs in the tests which have been checked by the respective station schedules afterwards:— W G Y, Schenectady, N.Y.; W J Z, Newark, N.J., in 1922; *W I P, Philadelphia; W O R, New Jersey. *K D K A, (April, 1923), Pittsburgh; W H A Z, Troy, N.Y.; *W N A C, Boston, Mass.; *W M A F, S. Dartmouth, Mass.; W J Z & W J Y, Radio Broadcast Central, N.Y. City, 1923-1924; W E A N, Rhode Island, W D A P & W. J. A. Z., Chicago. Those marked with an asterisk * are the first time those stations were received in Europe, according to letters from the station managers.

Of course, near stations such as the B.B.C. stations, French, Belgian and Dutch stations are all good.

The U.S. stations have been received after many hours out of bed, with the headphones on between midnight and 7.15 in the morning. I am at present rather unsuccessfully attempting to riddle the phenomena of "fading" and also to overcome this.

Harmonics from G.B.L., Ongar, French stations, etc., coupled with X's, make reception very hard indeed of the long distance stations.

Three U.S. stations have been audible on a loudspeaker across a room.

Wishing MODERN WIRELESS very many happy returns of the day.

Yours sincerely,
HENRY FIELD.

Baggrave Hall, Leicestershire.

THE BOOK WHICH SOLVES ALL PROBLEMS.

To obtain just the help you want in any kind of wireless difficulty simply consult

"500 WIRELESS QUESTIONS ANSWERED"

(post free 2s. 8d.) and you will find the solution of your problem.

Reclaiming Ebonite Panels

Don't throw that old panel away; it can be made new again quite successfully.

ONE of the most costly materials used in radio is ebonite; this is especially noticeable when one is continually altering the receiver. If drastic changes are made, almost invariably the holes which once held screws for components are not now in use, and often occur in awkward places, which do not add to the beauty of the receiver.

The writer, holding no brief for the scrapping of anything, decided to try to use up certain panels which had been laid aside for "scrap." Heel-ball was used with a certain amount of success, but, unfortunately, this material has one or two failings. The first is that it is soft, at least much softer than the surrounding ebonite; the second fault is that when the heel-ball is rubbed with a rag or duster, no matter how carefully, it takes a very high polish, and if the panel which is filled with this material is matted, the heel-ball filling shows up as bright spots.

A careful rub with fine emery-cloth will remove this shine, but if a duster is used to clean up the panel a little time later the heel-ball will again show up very conspicuously.

An Easy Method

This method of filling is the easiest and most successful when only a few holes are to be filled or the heads of countersunk screws hidden.

The heel-ball is held over the hole to be filled, and a lighted match or taper held against it so that it melts and drips into the hole. No success can be obtained by pouring melted heel-ball into the hole, as it will just run through. It might be thought that the same procedure could be followed with sealing-wax, but unfortunately black sealing-wax is much too hard and brittle and it cannot be easily cleaned up.

With heel-ball the hole should be filled to overflowing, as the centre sinks owing to contraction when heel-ball cools. With large holes a piece of packing behind the panel will greatly facilitate the operation.

When cold the surplus heel-ball should be removed with a chisel or knife and a final clean up with a fine piece of emery given.

With highly polished panels this method is ideal, as the high polish obtainable matches the panel, but is unsightly if used on matted panels.

While writing of heel-ball, a tip as to another use may be welcome to those who desire a highly polished panel.

Before the components are mounted on the panel (tinfoil surface must be removed always), a stick of heel-ball is rubbed on to the panel with a fair amount of vigour in all directions until all scratches left by emery-paper during previous operations are filled up. A rag is then used to remove as much surplus as possible, and a final polishing is carried out with a soft rag. This may take some time, but the harder and longer the rub (care being taken not to heat the panel by too much friction), the better the polish. If ever this surface gets dull, a little rub with a rag will soon revive it.

When a large panel with a good number of holes has to be filled, ebonite rod cut into the form of little billets a fraction over the thickness of the panel and forced into the holes has been found the most successful.

Ebonite rod of different diameters may be purchased from dealers advertising in this journal, the most useful sizes required being $\frac{1}{8}$ in., $\frac{3}{16}$ in., $\frac{1}{4}$ in., $\frac{5}{16}$ in., and $\frac{3}{8}$ in. The cost is not very high, 10 ft. of each of $\frac{1}{8}$ in., $\frac{3}{16}$ in., $\frac{1}{4}$ in., and $\frac{5}{16}$ in. being under ten shillings, including postage. This should be sufficient to fill a great number of panels.

There are two methods of filling holes with solid rod—*i.e.*, warm and cold.

Actually the warm method is better, but takes more time than the cold.

The Warm Method.

All the holes in the panel are drilled to $\frac{1}{16}$ of an inch smaller than the size of the rod to be inserted, and the panel warmed sufficiently to enable a thumb nail mark to be made in its surface. The panel should be kept as near as possible at this temperature during the whole operation, but great care should be taken to ensure its being kept perfectly

Quality

RADIO

COMPONENTS.

ASK YOUR DEALER FOR THEM

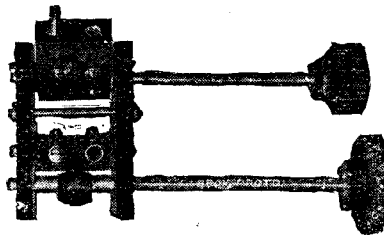

(Prev. Protected).

CAM-VERNIER COIL HOLDER

Price 9/-, on base 1/- extra.
With Reaction Reverse and Shorting Switch incorporated, 12 6.

Postage 4d.



BASKET COIL HOLDER

Price 1/6. Postage 2d.



CONDENSER & SET CLEANER

Price 9d each, Postage 2d.

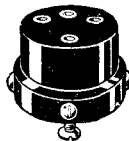
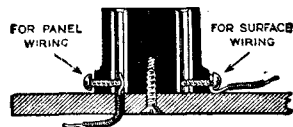

LEGLESS VALVE HOLDER

The valve holder itself acts as a jig for drilling.

Price 1/6. Postage 2d.

Fitted on square ebonite base for table use, 6d. extra.

LIST POST FREE.

GOSWELL ENGINEERING CO., LTD.,

12a, PENTONVILLE RD., LONDON, N.1.
Liberal Trade Terms. Phone: North 3051.

flat. An iron plate of any thickness is ideal for this purpose; but as few amateurs possess this, a fairly thick piece of wood, such as a table top, will be found most useful. If an iron plate is possessed and can be used for this purpose, it should be first heated, so that when placing the warm ebonite upon it the heat is not dissipated by the metal. With wood this loss of heat is not nearly so great.

The small billets of rod may be cut off to length with a small saw, but the best way is with a sharp knife. The rod should be first softened by heating and then parted by pressing the knife through it. The pieces should be allowed to cool off, when they are tapped with a light hammer into the hole. This should be done fairly quickly to prevent the ebonite billet collecting heat from the panel and softening. The billet should be hammered in until it reaches the other side of the panel. Great care should be taken to see that the ebonite panel is not bruised in any manner, as even small marks made will take a lot of rubbing out with emery-paper afterwards.

When all the holes have been filled the panel is allowed to get quite cold. The contraction of the panel will hold the billets very

tightly. The ends can now be rubbed down with emery-cloth, and finally the panel finished with knife polish and a little paraffin oil.

When tapping or drilling a hole which cuts partly through one of the billets care should be taken to prevent the drill pushing out the billet; no great strain must be applied to them.

The Cold Method.

The second method is to press the billets into the panel while cold. This is a little easier than the previous method, as the panel has not to be heated, and therefore no bending of the panel is experienced.

All the holes are first drilled out to $\frac{1}{16}$ in. less than the diameter of the billet to be used.

Before the billets are cut off in the gauge the end of the rod is slightly tapered; this should extend about halfway up the billet. A quick and easy way of making this taper is with a small tin cone into which is pressed a piece of emery-cloth. One of the cones used for icing cakes is particularly useful, or a metal pencil-sharpener can be pressed into use. The rod is pushed up into the cone and twisted with the fingers once or twice. This will take off sufficient ebonite to form the required taper.

The billet is then warmed slightly

and parted off with a knife. When cold this billet is pressed in the hole with the fingers, finally being pressed home between the jaws of a vice. With this method a danger of splitting the panel is obvious, but the writer has not yet had an accident. If a large panel is being filled, the holes near the centre of the panel may be tapped home with a small hammer. The holes near the edge, however, should always be done with the vice, as there is less chance of splitting the panel.

Usually the only holes near the edge of a panel are those holding the screws which secure the panel to the cabinet. It is not necessary to fill these, as they can be used again.

The panel is then rubbed down as in the previous method and final polishing carried out in the same way.

It is advisable not to clean up the back of the panel, except where the billets protrude, as care can then be exercised when drilling near an old hole.

If an old panel is to be cut up, all saw cuts should be done first to prevent fouling of any billets, as these cannot be expected to remain in position unless they are completely surrounded by ebonite.

W. H. F.

ECONOMIC ELECTRIC LTD.

VARIOMETER.
With White Ivorine Dial and Black Knob. Wavelength Range windings in parallel 250-420 metres, windings in series 200-1,250 metres. Windings green silk covered. Rotor and stator of red moulded insulation. Speech can be clearly distinguished on a loud-speaker 13 miles from 21.0 using this instrument and our R/22a Detector.

28/6



"One of the handsomest pieces of radio apparatus we have had the pleasure of handling and which in actual operating efficiency in no way belies its appearance."
MODERN WIRELESS.

COIL STAND
For Honeycomb Coils of highest class finish. Best quality ebonite matted, and afterwards highly polished. All connections permanently wired and no rubbing contacts, 13/-.



OUT TO-DAY!
Our NEW Radio Catalogue is just off the press and will be mailed by return on receipt of 4d. in stamps.



Head Office: 10, FITZROY SQUARE, LONDON, W.1.

Showrooms: 303, EUSTON RD., N.W.1

Branch and Works: TWICKENHAM.

*Telephony from over 400 miles
: : on Plain Crystal Set : :*

LONDON, BOURNEMOUTH, NEWCASTLE, GLASGOW
BIRMINGHAM, ABERDEEN and EIFFEL TOWER,
received on a plain crystal circuit using

MARKONITE

A customer writes that he can read telephony from all the above stations at Norfolk on his straight crystal set fitted with our MARKONITE crystal. We cannot guarantee these results for all districts, of course, but we do maintain that MARKONITE is the best crystal to use for distance reception.

"ROSEBROS MARKONITE" 1/- per Tube.

"ROSEBROS MARK IV" 1/- per Tube.

Use our Mark IV. for Crystal-Valve Sets.

"ROSEBROS CONCERT COILS" 15/- per set of 4.

From all Wireless Dealers or Post Free from any of our addresses below.

ROSE BROS. Electrical Co., Ltd.

TRADE: Liberal Discounts—Trade Count.r. Ask for Wireless List.

London: 25, Milton Street, E.C. 2.
Glasgow: 191a, St. Vincent Street.
Manchester: 25-27, Miller Street.
Bristol: 83a, Redcliffe Street.

CLIX

THE ELECTRO-LINK WITH 159 USES

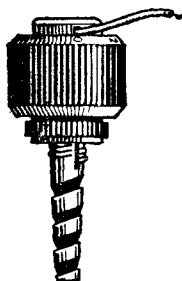

THE PIN of the RADIO and ELECTRICAL INDUSTRY

The introduction of this ingenious **COMBINATION WONDER PLUG and SOCKET** marks the advent of **A STANDARDISED SYSTEM OF INSTANTANEOUS WIRING.**

This inexpensive universal contact embraces every utility of **TERMINALS, PLUGS and SWITCHES,** which it entirely supersedes.

Retail Prices—

CLIX	3d. each.
Bushes (6 colours)	1½d. pair.
Insulators (6 colours)	1d. each.
Locknuts	½d. each.
CLIX with Bushes and Locknut	4½d. "
CLIX with Insulator and Locknut	4d. "

Ask your Dealer for particulars.

AUTOVEYORS, LTD. RADIO ENGINEERS and CONTRACTORS
84, VICTORIA ST, WESTMINSTER, LONDON, S.W.1

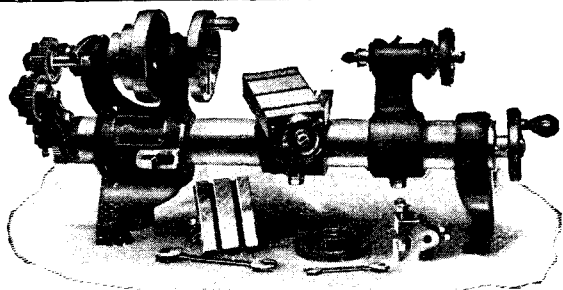

The DRUMMOND 4-in. Multi-purpose Lathe.

Make it yourself!

—half the fun in Wireless is gone if you buy everything complete

Winding coils, turning up formers, plugs, knobs—a hundred and one jobs, drilling, slotting, boring, screw-cutting—all may be done well and cheaply on the Drummond. A contact stud—or a bush for your car—make it yourself, and pay for the lathe with the money you save.

DRUMMOND Bros. Ltd., REID HILL, GUILDFORD.

—Post this Coupon—

Please send me, post free, lists of your small lathes, with details of deferred payment system.

Name

Address

(Send in unsealed envelope for ½d.)

7 Sterling Values from GAMAGES

ENGLAND'S PREMIER WIRELESS STORE.

To satisfactorily supply the amateur's every need is the real test of service. None but a firm with stocks of Gamage magnitude and trustworthiness can hope to survive the test. Gamage Prices are always what the Wireless Enthusiast is looking for—come and see for yourself! Post Orders may be sent with every confidence on our Money-back Guarantee.

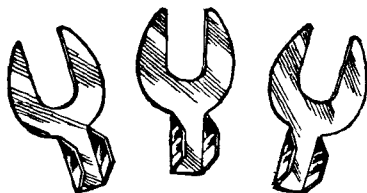

TERMINAL TAGS

As illustrated—obtainable in Brass, Tin or Copper. Exact size of illustrations. Price per doz. 6d. Postage on 1 dozen 1½d. 3 dozen sent post free. Lay in a stock for future requirements—it's well worth while.

Write for your copy of our New 1924 **WIRELESS CATALOGUE** The finest guide you can possibly have. **POST FREE ON REQUEST.**

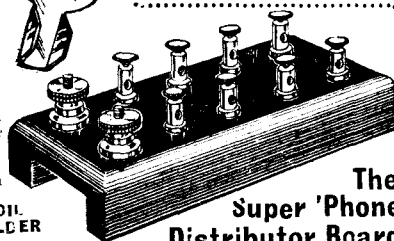

The Super 'Phone Distributor Board

A beautifully finished component with lacquered terminals. TO TAKE 4 PAIRS OF 'PHONES. Size 5 in. x 2 in. x 1½ in. Price 3/6 Post 4d. A most useful and practical accessory which should be ordered right away to avoid disappointment. Order direct from this announcement on our money back guarantee.

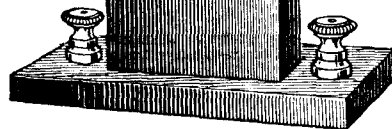

VALUE: COIL HOLDERS.

A most useful Coil Holder for the Amateur and Experimenter. Made in the best ebonite, terminals lacquered and THE SOCKET IS A PERFECT FIT. Price 2/3 Postage

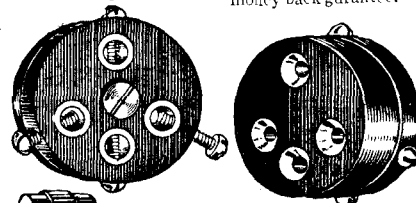

VALVE HOLDERS

This is the easiest Valve Holder to fit on the market and being its own template can be done by the mere novice. No soldering required. Excellent finish. In best ebonite. Illustration shows front and back views. Post 3d. Price 1/6 All prices now ruling at Gamages are remarkably low. It is therefore strongly advised to order your requirements immediately before prices increase.

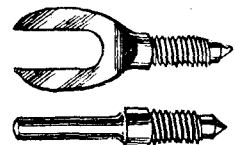

HANDY TERMINALS

Very useful For Aerial, Earth and Battery Wires, etc. Either type as illustration. Price per dozen 1/6 Postage 2d. The best terminals for you.

GET A PIECE OF PERMANITE CRYSTAL THE WORLD'S FINEST CRYSTAL.

PERMANITE CRYSTAL

Clear powerful results. Remains in adjustment longest. Price per large specimen 1/6 Post free.

FULLER'S BLOCK ACCUMULATORS

Special offer of ex-Government Stock but absolutely unused.

2 volt, 40 amp. post 1/-	10/6
4 volt, 40 amp. post 1/-	21/-
6 volt, 40 amp. post 1/6	31/6

Six accumulator sent post free.

GAMAGES, HOLBORN, LONDON, E.C.1
Cheapside House; BENEFINKS.

AT THE
BRITISH EMPIRE
EXHIBITION
THE
GRAHAM STAND
IS AVENUE II
BAYS II-13,
PALACE OF
ENGINEERING.



THE
WORLD'S
STANDARD

AMPLION

WIRELESS
LOUD
SPEAKER

Why an Amplion?

FIRSTLY—Because the Amplion reproduces in full volume, with remarkable clarity and in a delightfully natural tone.

IN THE SECOND PLACE—The general design, quality of materials used and exact workmanship in every detail establish a definite superiority compared with any other production.

THIRDLY—In the Amplion there is embodied the results of over 30 years' experience in research and the application of acoustic principles generally, as well as in the manufacture of Loud Speaking Telephonic apparatus for Naval and other Services necessitating the utmost efficiency and positive reliability.

AND AGAIN—The Amplion series comprise a variety of models appropriate to every condition or circumstance of use, and the prices—from two guineas—bring a genuine Amplion within the reach of every pocket.

Technically the Amplion is the outstanding Loud Speaker of the day and the ultimate choice of discriminating listeners-in.

Descriptive list W.T. mailed with pleasure.

ALFRED GRAHAM & COMPANY,

St. Andrew's Works, Crofton Park, London, S.E. 4.

Telephone : Sydenham 2820, 2821, 2822.

Telegrams : "Navalhada, Catgreen, London."

Showrooms : 25-26, Saville Row, W. 1, and 82, High Street, Clapham, S.W. 4.

W 47

B.B.C.

WIRELESS
DRY
BATTERIES

For
B.B.C.
Sets

No. 1 W.

Standard Pocket Lamp Size—4½ volt with patent spiral wire terminals and plug sockets to take Wander Plugs.

Note — 1 doz. = 54 volts

Used units replaced easily.

Connect as illustrated

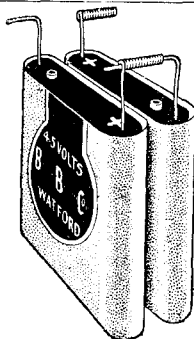

To connect in Series insert straight Terminal in Spiral of next battery. Bend spiral and thus ensure permanent electrical connection without soldering.

BRITISH MADE.

Patent applied for.

PRICE CARRIAGE PAID, 7/- PER DOZEN, WITH PLUG.

Standard Sizes :

No. 2 W. Slab, 16½ volts, 3-volt tappings, Size approx. 9 x 1 x 3 ins. ...	Price 3/- each
No. 4 W. Slab, 36 volts, 3-volt tappings, Size approx. 10 x 1½ x 3 ins. ...	6/6 ..
No. 5 W. Block, 60 volts, 3-volt tappings, Size approx. 9½ x 3½ x 3½ ins. ...	12/- ..

Prices include Wander Plug, Carriage Paid.

Manufactured by

Telephone : Watford 617.

The BRITISH BATTERY CO. LTD.

CLARENDON RD., WATFORD, HERTS.

"TANGENT"

Tuning Coils

—TESTED & TRIED—

On frames—robust and substantial

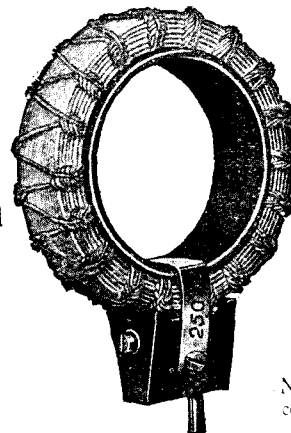

Their efficiency which is second to none, is not impaired by the special material of the frames.

No self-supporting coil excels them.

Say "TANGENT" to your dealer and refuse substitutes

Send for **Leaflet 101Q**

GENT & CO. LTD., FARADAY WORKS LEICESTER EST 1872

Manufacturing Electrical Engineers,

LONDON: 25, VICTORIA STREET, S.W.1.

NEWCASTLE-ON-TYNE: TANGENT HOUSE, BLACKETT STREET.

Reflex Wireless Receivers in Theory and Practice

By JOHN SCOTT-TAGGART, F.Inst.P., A.M.I.E.E.

This is the third article of an important series dealing exhaustively with dual amplification in all its forms.

FIG. 10 shows a simple single-valve dual amplification circuit. This circuit has been chosen because of its simple nature. A loose-coupled circuit is employed for introducing the high-frequency oscillations from the aerial to the grid circuit of the valve V_1 . A variable inductance L_1 is shown in series with a variable condenser C_1 , while L_2 is loosely coupled to L_1 and is also shunted by a variable condenser C_2 . Both the aerial and closed circuits are, of course, tuned to the incoming wavelength. The high-frequency oscillations are applied to the grid and filament of the valve, the connection to the filament being made through the condenser C_5 , which has a value of, say, $0.001 \mu\text{F}$. In the anode circuit of the valve we have the inductance L_3 , and the telephones T and the high-tension battery B_2 . The inductance L_3 of the primary of a fixed transformer $L_3 L_4$ is designed to suit the wavelength to be received. The telephones T are shunted by the fixed condenser C_3 of, say, $0.002 \mu\text{F}$ capacity for the purpose of by-passing the high-frequency currents from the anode circuit. Across the secondary L_4 are connected the crystal detector D and the primary T_1 of the step-up transformer $T_1 T_2$, which is of a type generally known as step-up intervalve transformers. The primary T_1 may be shunted by a condenser C_4 of $0.002 \mu\text{F}$ capacity, and is often done when a crystal detector is being used. The secondary T_2 is connected in the grid circuit of the valve V_1 , the condenser C_5 acting as a short circuit of T_2 in so far as high-frequency currents are concerned.

High-Frequency Potentials

The high-frequency potentials communicated to the grid G_1 of a valve V_1 are amplified by the valve, the amplified currents passing through L_3 and being passed on by inductive coupling to L_4 ; the oscillations in L_4 are detected by the crystal detector D and pulses pass through the primary T_1 of the step-up transformer $T_1 T_2$. Currents

of an alternating nature are produced in the secondary T_2 , and as the right-hand side of T_2 is connected to the filament, the low-frequency currents are applied to the grid. The low-frequency potentials applied to the grid now cause large low-frequency variations in the anode current of the valve, and these pass through the telephones T and operate them. As $L_3 L_4$ is an air-core transformer and the coupling, as regards low-frequency currents, is extremely weak, no low-frequency currents will be passed into the detector circuit. It is also hardly necessary to point out that the high-frequency currents passing in the anode circuit of the valve will in no way affect the telephones T , which will only respond

in circuit the current through the filament and through the rheostat will produce a drop of potential across the latter which may amount to 1 volt. The effect of this is that the negative terminal of the filament accumulator B_1 is at -1 volt potential with respect to the negative end of the filament F_1 . It will be noticed that the right-hand side of T_2 is connected to the negative terminal of B_1 . The result is that the grid G_1 is given a normal operating potential of about -1 volt. This is highly desirable, because the valve acts purely as an amplifier in the Fig. 10 circuit; it amplifies both high- and low-frequency currents, but in both cases it is highly desirable to avoid the establishment of grid current due to the grid becoming positive with respect to the negative end of the filament.

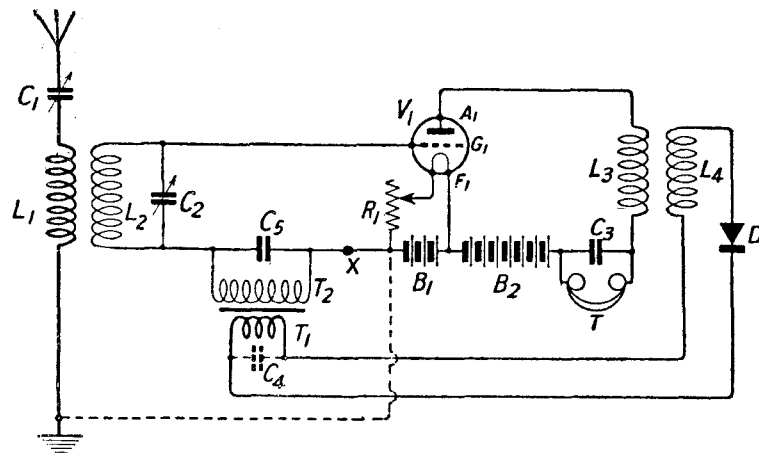

Fig. 10.—A simple single-valve dual amplification circuit.

to the amplified low-frequency currents produced after rectification.

There are several points of design which have been observed even in the simple circuit of Fig. 10. It may be useful to point these out. In the first place, it will be noticed that the filament rheostat R_1 is connected in the negative lead to the filament—i.e., the rheostat is connected between the negative terminal of the accumulator and one side of the filament. The effect of this is that when the rheostat is

By keeping the grid at a negative potential, grid currents will only be set up when the signals are very strong. By this little device distortion due to damping of the positive half-cycles of current, and consequent rectification, are avoided. If a larger negative potential is required a small "grid battery" is connected at the point X in the circuit so that some such operating point as B in Fig. 8 is in use.

It will also be noticed that the high-tension battery B_2 and the

telephones T are connected together at what may be termed the bottom of the anode circuit of a valve. The high-tension battery B_2 has its negative terminal connected to the positive terminal of a filament accumulator. By doing this we get the additional voltage of the battery B_1 communicated to the anode A_1 of the valve, whereas if we had connected the negative terminal of the high-tension battery to the negative terminal of the filament battery we should have lost this extra voltage. Some definite convention is highly desirable, and the practice of connecting the negative terminal of the high-tension battery to the positive terminal of the filament battery is one always to be recommended, except perhaps in very special cases which need not be discussed here.

Position of H.T. Battery

The question of whether the high-tension battery should be in the position shown or should change places with the telephones T is a doubtful point in a single-valve circuit. When two or more valves are used the high-tension battery should be connected next to the filament battery, but when a single valve is used there are arguments which may be advanced in favour of the idea of having the telephones next to the filament accumulator. The most cogent argument is that when the high-tension battery is next to the filament battery, as shown in Fig. 10, if there is any leakage between the telephones T and the operator wearing the telephones, a shock may be received. This is not likely to happen in the case of Fig. 10 because the accumulator B_1 is ordinarily insulated unless definitely earth-connected. If, however, an actual connection were taken from the negative terminal of B_1 to the earth, as shown by the dotted line in Fig. 10, the argument might apply. In any case, the author does not consider that this is an important point, because telephone receivers are generally well insulated and the chance of shock, or of injury to the telephones, is very small.

Special Earth Connection

It may be pointed out here that a connection between the negative of the accumulator and the earth, as shown by a dotted line in Fig. 10, is generally desirable in the case of a loose-coupled circuit of this kind and helps towards stability.

It might be asked, "Why should not the telephones T be connected

next to the anode of the valve?" Here we have an example of the principle that no piece of apparatus which is likely to have a capacity to earth or a leakage to earth should be connected near a point at high-frequency potential to earth. This question of capacity to earth is a very important one, and it might be as well to explain the meaning of the term. Anything which is connected by a short wire to the earth plate is considered as being at earth potential. If a large condenser is connected in between the earth and the object, the latter, to all intents and purposes, may be said to be at earth potential. Even a medium-sized condenser inserted in the lead between the earth and the object will not alter the fact that the object is substantially at earth potential when high-frequency currents are flowing through the leads to the earth. When, however, low-frequency currents are involved, a medium-sized condenser would not have the equivalent effect of an ordinary wire connection. If the condenser in the lead is of relatively small capacity, say $0.0005 \mu\text{F}$, high-frequency currents flowing through this condenser will set up potentials across it and the object previously mentioned will certainly not be at earth potential.

Effect of the Body

Now there are many objects of substantial size in a wireless receiving station, and the principal object is the operator himself. He is, to a certain extent, a conductor, and since he stands on the floor he acts like one plate of a condenser, the earth acting as the other plate. The human body, therefore, has a capacity to earth. If, then, we were to touch the aerial terminal of the receiver, it would be equivalent to connecting a large condenser across aerial and earth. Incidentally, it would also be more or less equivalent to connecting a leak across aerial and earth, because the operator is not usually perfectly insulated from the ground. The "capacity to earth" effect of the human body is particularly noticeable when the hand is placed near a condenser or other part of a sensitively adjusted receiver working on short wavelengths. The higher the frequency of the currents in a wireless receiver, the more susceptible will they be to interference by the capacity effect of the human body. In the case of low-frequency currents the capacity of the human body is not sufficiently great to interfere quite

as much with these currents. The result is that on an ordinary receiver we can touch either of the telephone terminals of the receiver without making a difference to the signals received. In the case of badly designed dual amplification circuits, or dual amplification circuits in which one or other of the telephone terminals is in such a position that by touching it one is altering the high-frequency conditions in the circuit, the signal strength may be greatly varied and perhaps low-frequency oscillations or buzzing produced. If, however, the low-frequency circuit is quite separate and unconnected, as regards mutual effects, to the high-frequency circuit, touching either terminal will not make much difference. This should be the case in the Fig. 10 circuit.

If, however, we had the telephones T connected next to the anode of a valve, the circuit would continue to operate, yet the results might easily not be so good, the reason being that a substantial capacity and a possible source of leakage is connected across the inductance L_3 .

Capacities to Earth

Any large body, such as a filament battery or high-tension battery, or even telephone receivers, have a capacity to earth. This capacity is the condenser effect between the battery, say, and the earth lead, and between the battery and the walls of a room and the floor, etc. Small objects, such as connecting wires, grid condensers and similar objects, have no appreciable capacity to earth, and any undesirable effect which might arise with a larger object is absent when the object is small. In the case of the high-tension battery and filament battery, these have a substantial capacity to earth, and the telephones also, especially when worn on the head, have a capacity to earth. A little thought will show that the effect of connecting the telephones T next to the anode in Fig. 10 would be equivalent to a condenser being connected across L_3 . Quite apart from the capacity of the different components to earth, they have a very important self-capacity effect towards each other, so that even if there were no capacity to earth it would still be undesirable to connect the telephones T next to the anode. For example, when standing near the receiver, the human body and high-tension and filament batteries would form a condenser, and since the telephones are being worn on

(Continued on page 755.)

"You are Right!"

They beat anything I've ever heard—"

IT is the unanimous verdict of everyone hearing the new GENERAL RADIOPHONES for the first time.

You, too, should ask your dealer for a demonstration, and compare them.

The strength, clarity and natural tone of their reproduction is unique—but when one examines the striking new features embodied in their design and manufacture, the "reasons why" become boldly obvious.

GENERAL RADIOPHONES will respond to signal intensity of .0000000011 of an ampere.

This is due to the extraordinary efficiency of the magnetic circuit; a new method of winding the coils; perfect insulation, and their remarkable accuracy of assembly—the air gap being automatically adjusted to within one half thousandth of an inch.

The receivers are matched in tone by means of visual indicating gauges invented by our engineers. The magnets are manufactured from expensive Cobalt Steel, and the Diaphragms are triple tested.

In appearance and finish they leave nothing to be desired; they fit any head instantly and there is not a single screw or nut to adjust.

GENERAL RADIOPHONES weigh only 7 ounces.

Make a point of hearing them at the first opportunity—they will be a revelation to you.

GENERAL RADIO COMPANY
LIMITED

Radio House, 235, Regent Street, London, W.1.

Telephone:
Mayfair 7152.

Telegrams:
"Algenrad, London."



GENERAL RADIOPHONES

FAMOUS FOR EFFICIENCY

Every pair carries a full guarantee **20/-**
per pair.

"A REFLEX UNIT FOR ADDING TO A CRYSTAL SET"

The transformer used in the unit described under the above title in this issue of MODERN WIRELESS is the

G.R.C. AUDIOFORMER

PRICE **15/-**

Chosen for Efficiency

Your local dealer can supply you.

Clarke's "ATLAS" SPECIALITIES



Dealer : " Oh, yes ; besides **CLARKE'S "ATLAS " PATENT PLUG-IN COILS**, we stock all other "**ATLAS "** **SPECIALITIES**, such as, for instance, the "**ATLAS " VARIOMETER**, which comprises an ebonite ball-type rotor, swivelling inside an ebonite tube stator. This Variometer, which is of the one-hole fixing type, covers all the British Broadcasting, and is an extremely efficient apparatus.

Further, the "**ATLAS " FIXED CONDENSER** possesses special features, one of which is that the casings and inserts are made of Bakelite—well known as one of the finest of Insulating Materials, and the copper-foils and sheets of mica forming the dielectric are held under pressure. The value, therefore, of the Condenser is kept constant all the time.

Again, **CLARKE'S "ATLAS " VARIABLE CONDENSERS** are built not simply for sale but for use in the positions for which the Condensers, of their respective capacities, are destined. They are supplied with full-round or semi ebonite end plaques, the fixed and moving Aluminium Vanes being correctly spaced and beautifully balanced."

Customer : " And do Clarke's make Coil Stands, Rheostats, etc. ? "

Dealer : " Yes ; their latest type of "**ATLAS " 2-WAY AND 3-WAY HORIZONTAL AND VERTICAL COIL STANDS** is second to none. They are fitted with plugs and sockets set at standard centres, and the Stands are provided with a neat Tension Adjustment, all fittings being nickel-plated.

Respecting Rheostats, **CLARKE'S "ATLAS " 'VELVET TOUCH ' RHEOSTAT** is the acme of perfection, and, as its name implies, the action of the contact arm passing over the coils of the resistance spring produces just that ' Velvet Touch ' which, in the cheaper types of Rheostat, is so conspicuous by its absence.

The large ohmic value of this ' Velvet-Touch ' Rheostat—viz., 6 ohms—makes it impossible for the full voltage to be put on to the Filaments straight away ; consequently the life of your Valves is increased."

See our Exhibits in the Palace of Engineering,
British Empire Exhibition, Wembley.

Sole Manufacturers :

H. CLARKE & CO. (MANCHESTER), LTD.,

RADIO ENGINEERS,

"ATLAS" WORKS,

OLD TRAFFORD,

MANCHESTER.



'Phones :
683 & 793 Trafford Park.

'Grams :
"Pirtoid" Manchester.

Reflex Wireless Receivers in Theory and Practice.—
(Continued from page 752).

the head, there is a condenser effect between the telephones and the human body. Here again we should have a capacity effect across the inductance L_3 . Even if the telephones were lying on the table, they and their leads would form a condenser with the batteries. Not only is there a capacity effect in these cases, but there is usually a certain amount of leakage. This may easily happen when telephones are being used, but it is far less likely when a loud-speaker is being employed. For this reason, and also because a loud-speaker has no very large capacity to earth when kept away from the batteries, it is far less injurious to have a loud-speaker connected next to the anode of the valve in the circuit of the Fig. 10 type than telephone receivers. This point must be borne in mind, as, indeed, must all the points dealt with here, because it is sometimes necessary to connect the telephones or loud-speaker in a position which is not the most satisfactory from the point of view of general principles. Special cases may necessitate the inclusion of telephones or loud-speaker next to the anode of a valve and in between the anode and an inductance carrying high-frequency currents. The dangers which are likely to arise by doing this should be noted.

An Additional Point

An additional point which should be borne in mind is that when telephones are used the capacity they have in respect to earth and other pieces of apparatus is continually varying owing to different adjustments of the telephones on the head and to the fact that the operator is not absolutely stationary, and to the fact that his hands are being used to make various alterations in tuning, etc. While a capacity effect of this nature is bad, a varying capacity effect is very much worse, particularly when receiving on short wavelengths and when the apparatus is adjusted in a very sensitive manner to a weak signal, *e.g.*, when using reaction. When a loud-speaker is being used we can say that there is no leakage, but only a capacity effect, and although this capacity effect is not desirable, yet it is not very harmful in many cases because the loud-speaker is stationary and the capacity effects remain constant.

As regards the condenser C_3 of Fig. 10, this is a by-path condenser intended to allow the ready passage of high-frequency currents

in the anode circuit. The windings of the telephones have a high impedance which would tend to choke back the high-frequency currents. In actual practice the condenser C_3 may sometimes be omitted without any disadvantage. In this case the high-frequency currents pass through the condenser formed by the parallel leads to the telephones and the self-capacity of the windings.

The condenser C_3 is, like other condensers used in dual amplification circuits, sometimes desirable, while sometimes it is best omitted. It is in most circuits a matter for individual experiment, and its value is also a matter for trial. There are really three capacities for fixed condensers in dual amplification circuits, although the ordinary self-capacity of the telephones or transformer windings is sometimes sufficient without being supplemented by any extra condenser. Condensers of $0.0003 \mu\text{F}$, $0.001 \mu\text{F}$ and $0.002 \mu\text{F}$ capacity are useful to try across different points in a dual circuit. It is owing to the fact that different telephones and different transformers have different self-capacities and different impedances, and these two properties have a very important bearing on the tendency of the dual amplification circuit to oscillate at low frequency.

The Condenser C_4

The condenser C_4 in Fig. 10 may, in practically all cases, be omitted, because the primary T_1 of the step-up transformer T_1 , T_2 , usually has sufficient self-capacity. Here, again, it is a matter for experiment, but the author has found that as a general rule the condenser may, in the case of most transformers, be omitted. It will usually be found in most dual circuits that if a condenser is really of any use its capacity should be about $0.002 \mu\text{F}$.

The condenser C_5 is of greater importance, and here it may be stated as a rule that some additional capacity will be required. A fixed condenser C_5 is employed to shunt the secondary T_3 , and the value of this capacity may be $0.0003 \mu\text{F}$, $0.001 \mu\text{F}$ or $0.002 \mu\text{F}$, according to the type of transformer used and the actual type of circuit employed. In the case of the Fig. 10 circuit the condenser C_5 may have a capacity of $0.001 \mu\text{F}$, and this will probably always be satisfactory. It is to be noted that if too large a condenser is employed here, it will, without affecting the high-frequency circuit, act as a partial short-circuit for the low-frequency currents supplied

by T_2 . A very small condenser in place of C_5 would have no material effect on the potentials supplied by T_2 , but a condenser of very large capacity, say $1 \mu\text{F}$, would render the arrangement extremely insensitive. The author has found that it is quite possible to detect the difference in signal strength between the $0.001 \mu\text{F}$ condenser and the $0.002 \mu\text{F}$ condenser, but there is really not very much difference. In any case, a condenser of larger capacity than $0.002 \mu\text{F}$ should not be employed. The value, or even need, of these fixed condensers constitutes the great unknown factor in the problem of effective dual amplification, and anyone who is experimenting with dual amplification circuits should bear this in mind.

Position of the Crystal

Another point is in connection with the position of the crystal detector. This detector should be connected at the high-frequency end of the coil L_4 . It will usually be found that even in the case of a transformer there is a "high-potential" end and a "low-potential" end, the latter being connected or tightly coupled to a portion of a circuit connected to earth, or to the batteries associated with a valve, these being taken to be at earth potential. Telephone receivers, or the primary of a transformer, should never be connected next to the high-potential end of a coil. Nevertheless, if this is done and the crystal detector is connected at the low-potential end, signals will still be received, but they will not be as strong as if the crystal, or grid in the case of a valve detector, is connected directly to the high-potential end of the coil, and the transformer, or telephone receivers, connected to the low-potential end. When high-frequency transformers are used, as in Fig. 10, a reversal of leads to L_4 should be tried. In some cases the above remarks will not apply, and no appreciable difference in signal strength will be noted, but in others, and especially in those cases where the detector is connected across a single coil in the anode circuit (the high-potential end of the coil in that case being the one nearest the anode), it is most important to connect one side of the detector directly to the high-potential end of the inductance.

NOTE: The fourth article in this series will appear in our next issue. As so many would-be readers have been disappointed on finding "M.W." sold out, make sure to place a standing order with your newsagent.

**Working & Finishing
Ebonite Panels.**

THE appearance of the finished set depends so much upon the way in which the panels are dealt with by the constructor, that it is well worth while to take a little extra trouble over it. Beginners at the business of making up sets are rather apt to dash at things, seizing a piece of ebonite, marking it out so hastily that many of the holes have later to be re-drilled and then mounting it upon the set with rough edges and with its surface blemished by scratches and tool marks. One is so anxious to get the set working quickly that any time spent over finishing up its parts seems almost to be wasted. But slapdash work is never satisfactory, and the extra time required to do things really well is so small that no one need grudge it.

In the first place remember that there is unfortunately ebonite and ebonite. If it is of good quality it is one of the best of insulating materials, offering an enormous resistance to the passage of elec-

tricity and being very little affected by damp. Bad ebonite, however, is a very different thing. It is usually patchy; some parts of it will show quite good insulating properties when tested, whilst others have so poor a resistance that terminals or other connections mounted there will be practically short circuited so

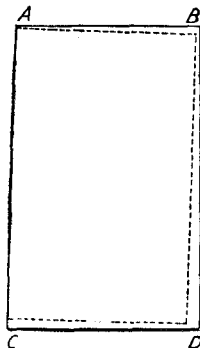

Fig. 1.—Marking off.

far as high-frequency currents are concerned. A friend of mine not long ago spent a great deal of time in making up a 5-valve set on an ebonite panel. When it was finished it was found to be almost useless owing to the badness of the ebonite. Therefore, when you buy the material for your panels, get it from a good firm and obtain the

assurance that it is of high quality. It is poor economy to save 6d. per lb. by buying stuff that is of no use.

If you are wise you will get your panels cut for you at the shop at which you make your purchase; but there is a point to be noticed here. One very seldom receives a panel that is cut absolutely square. Hence it is advisable to order the pieces $\frac{1}{8}$ in. or so longer and wider than they will be when finished up. This allows room for the necessary trimming.

We will suppose that you are making a 6 in. by 9 in. panel. Order it $6\frac{1}{8}$ in. by $9\frac{1}{8}$ in. When it comes, go over it with a setsquare so as to find out which edge is the best one to use as a reference for measurements. This will be the one whose retention involves the least amount of trimming of the others and allows the panel to be brought down easily to its final exact dimensions. Make this edge absolutely straight. Now using this edge (AB, Fig. 1), mark out with setsquare and scribe the two edges that are at right angles to it (AC, BD). Never use a pencil for marking out ebonite. Its "lead" deposits a layer of graphite upon the panel, and graphite offers a path of medium resistance only to

(Continued on page 767)

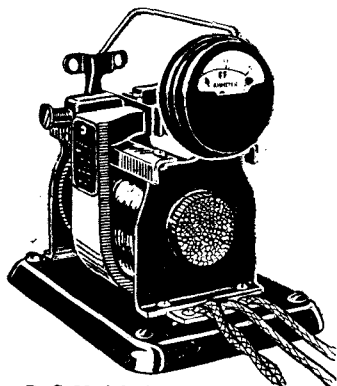

D. C. Model £6 : 15 : 0

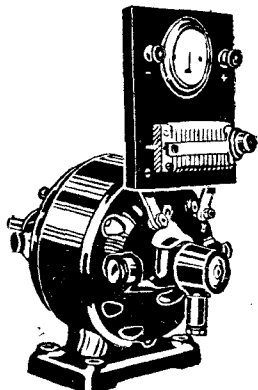

A. C. Model £6 : 6 : 0

DON'T BE OVERCHARGED. *You can avoid this experience.*

From the "Daily Mail," April 12th, 1924.

WIRELESS BATTERIES. Protest against cost of recharging.

Wireless enthusiasm in Southampton and district has been damped by the decision of a meeting of accumulator recharging businesses—mainly garages—to increase their charges. It was intended to increase the charge of 1/6 for the most used type of accumulator to 3/6, and although, because of criticism, a slightly smaller increase may result, the prices will tend to restrict amateur wireless activities. The local radio society is organising enthusiasts to fight against any increase, holding that the more recharging that can be found the cheaper the operation should become. One of the members said he had costed the work, and the result showed that a charge of 1/6 yields a profit of about 75 per cent.

ANOTHER TESTIMONIAL

Mr. Charles Kirtly, Newcastle-on-Tyne, writes:—"It might interest you to know, that by our books, 15 batteries have been charged by your 'Ella' charger, all of them 6 volt—60 and 80 amp., and 1-2 volt 20 amp. The extras in running being 6 carbons worn down on the input side. The little machine (it is little compared to our 6 horse motor) seems to work splendidly and charges very well indeed."

"ELLA" BATTERY CHARGERS enable wireless and other batteries to be charged AT HOME at a trifling cost. Be independent of overcharges by installing an "ELLA." At the same time you can charge your friends' batteries.

DELIVERY FROM STOCK. Specify frequency for A.C. 40 to 60 as standard; other frequencies £1 extra on A.C. Model.

LIONEL ROBINSON & CO.

3, STAPLE INN, LONDON, W.C.1.

Phone: Ho born 6323 (Two lines).

Salvage by Wireless

By Lt.-Col. HAROLD F. TOWLER

The Advent of Wireless

The advent of wireless has now very largely removed the element of chance in salvage. At any time now after there has been bad weather in the North Atlantic a glance at the shipping casualties will show that the "S.S. — in Lat. — Long. —" (say the middle of the Atlantic) "reports her rudder carried away by heavy sea," and the vessel can be communicated with by her owners, a good idea of the damage obtained, and instead of a casual tow from any vessel, it may be decided that some other vessel of the same line may undertake the work. (This would not affect the crew's right to claim salvage, nor the owners, if the vessel is insured.) Should the case be more urgent than this and require prompt action to avert serious danger, a wireless message puts the vessel in touch with any other vessel that may be near, and there may be a race to pick her up.

SALVAGE is a subject of absorbing interest to the seaman. In some cases of wreck or accident to other ships there are lives to be saved and it is then a case of cheerful work for all hands, personal risk for some of the crew, and a welcome to those members of the crew of the wreck who are saved. There is in this case no question of personal gain, but the work is done none the less heartily for all that. Sometimes if the wreck belongs to a foreign country, the captain may receive a present of a pair of binoculars and the lifeboat crew be given a watch apiece or something similar to commemorate the occasion.

first on the value of the cargo and ship saved, and, secondly, on the amount of risk to the ship which did the salvage work. Any personal risk to the crew or any men who manned the lifeboat which established communication between the two ships at sea is taken into consideration, also the distance the ship was towed, the weather experienced during the tow and the time occupied are taken into account.

How Payment is Made

All these points are decided by the court in London and the decision of the court gives a lump sum payable to the owners of the salving vessel, a sum payable to the captain and a further sum divisible amongst the crew in certain proportions. The captain's share may range from £100 to £2,000.

Saving Property

But salvage proper is a very different matter. In this case, it is not a question of saving life, but of saving property. Salvage may arise from many causes and may range from the case of the steamer whose propeller has worked loose or dropped off in mid-Atlantic, a vessel whose rudder has been broken by heavy weather, to the case of a vessel whose engines have broken down when close to a dangerous shore, or to the vessel which has actually gone ashore and has to be got off again as soon as possible before bad weather comes and the consequent heavy sea breaks her up.

One of the simplest salvage cases I have heard of took place near Las Palmas. A steam tug was towing a large barge out from England and ran short of coal a few miles north of the island. Finally it was decided that the tug could reach port with the coal remaining if she were not towing the barge; it was therefore decided to leave the barge, go into Las Palmas for coal and return in about thirty-six hours to pick up the barge again.

A Recent Example

As an example of the modern method of dealing with accidents: In early May, 1920, one of the smaller Cunard steamers, fitted with Radio Communication Company's wireless, left New York for home. When 120 miles out to sea, her propeller shaft broke, leaving her practically helpless. Within a few minutes the captain had a message transmitted via New London coast station (WLC) to the New York office of the company, and within a very short time received a reply to the effect that tugs were on their way to tow the vessel back to New York. The vessel was picked up in due course by the tugs and towed back to port without further incident.

Pre-Wireless Days

Before the days when wireless was fitted to so many steamers, the question of salvage was absolutely a matter of luck. Many vessels might pass quite close to a vessel requiring assistance without sighting her, until some vessel luckier than the others sighted her and took on the strenuous task of towing her to safety.

A Simple Action

The barge after it had been left to its own devices drifted to the northern end of the island, propelled by the trade wind and current. A fisherman sighted her when she was nearing the shore, and boarded her. He lowered her anchor down to the full extent of the cable and then left her. She drifted in farther towards shore; the anchor touched bottom and held her until next day when the tug returned to find her anchored close to the shore.

The reason for enthusiasm for salvage, which undoubtedly means hard work, is that every member of the crew shares in the award.

On the arrival of the two ships in port, the captain of the rescuing vessel puts in his claim and the distressed vessel has to give a guarantee of payment for the services before she can leave the port. The amount payable depends

Later the fisherman received a handsome part of the barge's value as a salvage award for his half hour's work, because it was held that, but for his action, the barge would have drifted ashore and become a total loss.

THE DOUBLE DUAL

To the Editor of MODERN WIRELESS.

SIR, — I have just roughly wired up the Double Dual receiver described in the March MODERN WIRELESS, and am getting wonderful results with it. Manchester, Newcastle, Glasgow, Aberdeen and Birmingham come in at good strength on small loud speaker. I have L.F. secondary as choke Igranite transformer, Watmel anode and grid resistance, Hertzite with silver, Ora and Ediswan R valves with 50v. H.T. 35 aerial coil, 50 and 75 respectively on the anodes. Aerial 25 ft. high, 70 ft. single wire on high ground.

Yours Truly, T. SWEETING.

117, Willow Park,
Baghill, Pontefract.

HULLO

PLEASE INCLUDE POSTAGE where mentioned, unless marked post free, to save delay.

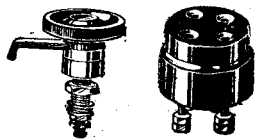

This first-class Switch Arm, with 12 Studs, 12 Nuts, 12 Washers, Callers 10 1/2 d.

By post 1/6 Set.

EBONITE COIL STANDS FOR HONEYCOMB COILS.
Long or Short Handles. Brass Fittings.
2-way, 3/3, 4/6, 4/11, 5/11,
3-way, 4/6, 5/11, 6/6, 6/11,
Post 1/- each.

SHAW'S GENUINE HERTZITE
Guaranteed Genuine.
Beats all other "Ites."
1/- Post 3d.

H. T. BATTERIES.

30 v. .. 4 3 and 4 6
36 v. .. 4 9 and 5 6
60 v. .. 7 6, 8 6 and 10 6
Post 1/- each.

LISSEN PARTS
Post 6d. each.

WEST END STOCKISTS OF LISSEN PARTS. COILS, ALL NUMBERS, etc., etc., at LIST PRICES.

Lissen T.1. Transformer 30/-
Lissen T.2. Ditto 25/-
Lissen T.3. Ditto 16 6
Variable Grid Leak 2 6
Variable Anode Resistance 2 6
Lissenstat Minor 3 6
Lissenstat 7 6
Lissenstat Universal 10 6
Lissen 2-way Switch 2 9
Lissen Series Parallel ditto 3 9
Post 6d. each.

"FILOSTAT"

FILAMENT RESISTANCE.
Controls ONE HOLE TO SHORT CIRCUIT.
D.E. as well as R. VALVES. Screw Connections. No Soldering.
2/6.

VALVES

All New Stock. No Job or Bankrupt Lots.
Cossor P.1., P.2. 12/6
Ediswan "R" 12/6
Marconi "R" 5 12/6
B.T.N. "R" 12/6
Mullard Ora 12/6
Marconi D.E.R. 21/6
Ediswan D.E.R. 21/6
Marconi D.E. 3 30/-
Mullard, Ediswan, '06 30/-
Reg. Post 1/- each.

HEADPHONES N. & K.

Famous for Comfort.—Every user of N. & K. Phones comments immediately on their comfort and the way they exclude outside sounds. This is due to two things—the extra size of the phones, covering the ear completely, and the leather-covered head bands, which have an additional sanitary value.

N. & K. was designed by one of the world's foremost makers of telephone and other scientific apparatus. It was designed especially for telephone reception, whereas most radio phones in use to-day were originally designed to receive telegraphic spark signals. The diaphragm is larger and more sensitive, and is placed at a carefully measured distance from the poles. Even the sound chamber is differently arranged. The workmanship lives up to the world-wide reputation of European precision instrument makers.

4,000 ohms 12/9
Non-Rustable Diaphragms 13/9
Post 1/- Pair.

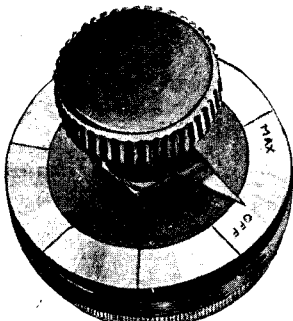

PEERLESS RHEOSTATS

6 ohms with dial 4 6
15 ohms for Weco, etc. 4 9
30 ohms for '06 type 5/-
Post 3d. each.

ACCUMULATORS

New, Best Makes.
2 v. 40 amp. 10 6 and 9 11
4 v. 40 amp. 19 11 " 17 6
4 v. 60 amp. 23 11 " 21 11
6 v. 60 amp. 32/- " 28 6
6 v. 80 amp. 36 6 " 32/-
6 v. 100 amp. 45/-
Post charge 1/6 each.



CRYSTAL DETECTORS

Enclosed Glass.
As Sketch, Brass or Ebonite.
Small 1/- 1/3 1/6
Large 1 5 1/6 2/-
Nickel, Large 2/-
Perikon, Large 2 2 Brass.
" Small 1 8
(Including Zincite and Bornite).
Post charge 9d. each.

HEADPHONES.

Post, 4,000 ohms, 1/- pair.
STERLING.—Latest Model
B.B.C. Duralumin Headbands. Very Light. Pair 25/-
Get Genuine Goods. See Sterling's have Duralin Bands and No. on Box R1260A.
BRUNET.—Every Pair stamped Genuine Only Supplied.
Worth 25/- Pair 14 11
SIDPE.—Stood the Test of Time
Pair 12 9
BRITISH THOMSON-HOUSTON.—Very fine Phones.
Pair 25/-
PREMIER B.B.C., a very fine English Phone, light in weight, comfortable to wear, no spacing washers. Try them and you won't be disappointed, as they are honestly worth much more. 4,000 ohms, per pair 17 6
BRUNET.—8,000 ohms. For Crystal Sets 19 11
BRUNET.—4,000, New Model. "A" Type 18 11
World-Famous Headphones
CONTINENTAL
ERICSSON E.V. TYPE.
4,000 ohms. Many thousands sold last year 13 9
T.M.C., B.B.C. Very Good Value 18 6
Post charge 1/- pair.

DUPLIX CONDENSERS

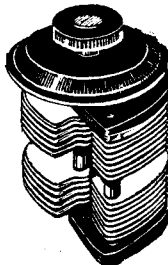

This Condenser is composed of two equal units, of '00025 mfd. operated by one Knob and Dial, thereby enabling you to tune two circuits by one turn of the dial. Can be used in series or parallel. Complete, as shown with aluminium end. Knob and dial.

For Tuned Anode Circuits.
13/6. Post 6d.

L. F. TRANSFORMERS

Post Free.
Radio Instruments 25/-
Igranic Shrouded 21/-
Formo Shrouded 18/-
Brunet Shrouded 14 11
General Radio 83 14 6
Formo Open 12 6
Raymond Special 11 9
Lissen T.1. 30/-
Lissen T.2. 25/-
Lissen T.3. 16 6
Powquip 2-1 14 11
Tested on Aerial 14 11

EBONITE 3/16 in.
6 x 6 1/3
8 x 6 1/9
9 x 6 2/-
12 x 9 4/-
12 x 12 5/-
Post 6d. Piece.

LOUD SPEAKERS
Starling Baby 55/-
Starling Flora 60/-
Amplion Junior 42/-
Sidpe Loud Speaker Complete 25/-
Post Free.

PLEASE ADD CORRECT POSTAGE.

FIXED CONDENSERS.

Post 3d. each extra.
Edison Bell Fixed '001 1/3
Do. '001 to '0005 1/3
Do. '002 to '006 2/-
Do. '0003 and Grid Leak 2 6
Raymond Fixed '001 10d.
Do. '0002 to '0005 10d.
Do. '002 to '005 1/-
Do. '004 to '006 1 6
Do. '0003 and Leak 1 10
Grid Leak 1/-
Dubblier Fixed '001 3/-
Do. '002 to '006 3/-
Do. '0001 to '0005 2 6
Do. '0003 and Grid Leak 5/-

FILAMENT RESISTANCES.

Post 6d. each extra.
Ormond Fils. Rheostat 2/-
Raymond do. 2 1/2
Rheostat and Dial 2 6 and 1 11
Ajax 25 5 4/-
Ajax with Vernier, 30 5 ohms 5/-
Ajax Potentiometer, 464 ohms 6 6
T.C.B., 6 ohms 4/-
T.C.B., 13 ohms 4/-
T.C.B., 30 ohms 4/-
Do. Potentiometer, 300 ohms 5 6
Igranic 4 6
Do. Potentiometer 7 6
Post 6d. each extra.

"PERFECTA."

Anode Res., 50,000 to 100,000 ohms 1/11
Var. Grid Leak 1 9
Post 3d. each extra.

SOMETHING NEW.

5/6
The "REVO" Little Gem Crystal Set.
Plus 1/- tax. Post 1/- extra.
Approved by Postmaster-General.
Licensed by B.B.C.
Handsome appearance. Receives up to 20 miles with P.M. 9 standard aerial.

POST FREE.

Spade Screw Terminals doz. 1 6
Pin do. doz. 1 3
Ebonite Dial and Knob 1 4
Do., Extra Quality 1 6
Ebonite Valve Holders 1 3
Valve Sockets, Best doz. 1 3
Do., Plain doz. 1 1
Terminals, Telephone doz. 1 6
Do., Pillar doz. 1 6
Do., Small Pillar doz. 1 4
Do., W.O. Patt. doz. 1 6
(All above with Nut.)
Insulating Sleeving, 3 yds. 1 3
Tinned Copper, 3 yds., 14 or 16 gauge 9d.
Do., 3 yds., 18 or 20 gauge 6d.
Ebonite Coil Plugs, 2 for 2/-
Do., on Stand 1 5
100,000 ohm Resistance 2 6

VARIOMETERS.

Edison Bell 15/-
Igranic 15/-
(Ebonite, Internally Wound)
Post Free.
Ebonite, Wound D.S. 2 11 4 6
Do., Ball Rotor 5 11
Post 1/- each.

RIGHT OPPOSITE
DALY'S
GALLERY DOOR

K. RAYMOND
27, LISLE STREET, W.C.2

HOURS OF BUSINESS:
DAILY - 9 to 7.45
SUND. 10.30 to 1

PHONE: GERRARD 4637.

-EVERYBODY-

SUPER CONDENSER WITH THREE PLATE VERNIER "IT" FOR VERY FINE TUNING

*001 12/6
*0005 11/6
*0003 9/6

Reg Post 6d. Set.

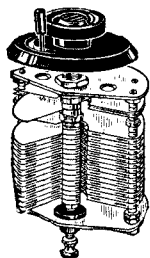

The following parts for **ENCLOSED ST. 100 Receiver.**

Wireless Weekly, April 23.

2 0.0005 Variable condensers (New type K. Raymond).

2 Vernier attachments.
Duplicator fixed condensers:

1 0.0001 1 0.0004
1 0.001 1 0.002
1 0.004.

2 Powquip, L.F. Transformers.

1 Burndept Crystal Detector.

1 Two coil holder.
2 Lissenstats.

2 Valve Holders.

1 Watmel 50,000—100,000 ohm resistance.

16 Terminals at 1 1/2d.

2 Valve windows.

1 Lissen Push-Pull switch.
Wire, covering, screws,
"Nugraving," etc.

ALL ABOVE
POST FREE

£4 12s. 6d.

Brown's Baby Loud-Speaker, 48s.

Thousands of Bargains for Callers.

RAYMOND

VARIABLE CONDENSERS

Our Air Dielectric Condensers are the simplest and MOST efficient on the market. Lowest in price. Highest in quality. Made for panel mounting and are the most suitable condensers for Broadcasting or Amateur work. They have passed THE TEST for guaranteed capacities, are scientifically accurate and built for durability.

New Model, POST 6d. SET EXTRA.

*073 in. SPACERS.		
Capacity.	Plates.	Price.
*001	49	7/11
*00075	37	6/11
*0005	25	5/11
*0003	15	5/3
*0002	11	4/11
*0001	5	4/3

Vernier, 3/3 (No Dial).

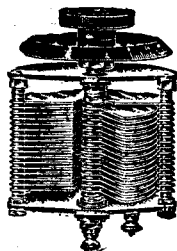

Prices include KNOB and Dial. Without Dial 6d. set less.

National Laboratory Certificate.

Above new model specially adapted for taking up min. amount of space. All parts nickelled. PASSED NATIONAL LABORATORY TEST. One hole fixing.

TRADE SUPPLIED.—Good terms on Condensers.

"A" TYPE. POST 6d. SET EXTRA.

*088 in. SPACERS.		
Cap. Approx.	Plates.	Price.
*001	57	6/6
*00075	43	5/9
*0005	29	5/-
*0003	19	4/6
*0002	13	4/-
*0001	7	3/6

Vernier, 2/6 (No dial).

Above "A" type is a wonderfully cheap and reliable condenser. One hole fixing. Thousands of testimonials from satisfied users.

POST ORDERS

from this column must add 3d. extra in each 1/- NOT SENT OTHERWISE.

Telephone, large	each	1 1/2d.
Telephone	each	1d.
Pillar	1d. & 1 1/2d.	
W.O. patt.	2 for	2 1/2d.
Large size Pillar	each	3d.
Various	doz. 1/- & 1/6	
Valve Sockets	doz. 9d. & 1/-	
Contact studs	doz.	4d.
Nuts	3 doz.	6d.
2 B.A. Rod	foot	3d.
4 B.A. Rod	foot	2 1/2d.
Valve Pins	2 a 1d.	
Brass Bushes	doz.	1d.
Spade Tags, best	doz.	3d.
Screw Spade Terminals	1d.	
Pin Screw do.	4 for	3d.
Stop Pins	2 a 1d.	
Plug and Socket	pair	1 1/2d.
Easyfix Cup		1 1/2d.
Switch Arms	5 1/2d., 6d., 8d.	
Do. with 12 Studs and Nuts and Washers		10 1/2d.
English Flash Lamp Batt.	doz.	4/-
H.T. Batteries, 36 v.		5/-
H.T. Batteries, 60 v. 3/6 & Filament Res., with Dial		10/6
Set of Names (12)		2/-
0-300 Dial		5d.
Scales (Engraved 0-150)		5d.
Insulators, Egg	6 for	3d.
Aerial Wire	100 ft.	1/6d.
Extra Hard Drawn, 7/22	100 ft.	2/6
Valve Windows		7d.
Res. Dials, 0-100		4d.
Ebonite Dial and Knob, 0-180		1/1 & 1/3
Filament do. and Knob		9d.
Filament Dial, 0-10		6d.
Fixed Condensers to .001		10d.
Do., .002 to .005 & .006		1/3
Ins. Screw Eyes		1d.
4 Cats Whiskers (1 gold)		3d.
Gold Whisker		2d.
Shaw's Hertzite	9d.	1/-
Zincite, 6d.; Bornite		6d.
Coil Holders	1/1 & 1/3	
Coil Plugs, Ebonite, 6d., 3d., 1/6		
Do., on Base	1/- & 9d.	
Best Valve Holders		1/3
3 makes, above	9d., 1/-, 1/3	
Tinned Copper, 16, 18, 20 g.		1/-
Sleeving, best	3 yds.	3d.
Copper Feil	ft.	3d.
Rubber Lead-in, 10 yds. 1/- & 1/3		
Bell Wire, D.C.C. I.R.C.	to yds.	5d.
Twin Flex	12 yds.	1/6
Heavy Rubber Lead-in	yd. 2d. & 3d.	
Basket Coils (6) 200/3, 500		1/9
Waxless (5)		1/11
D.P.D.T. Switches for Panel		1/6
S.P.D.T. do		1/3
Telephone Cords	1/6 & 8c.	
Grid Leak (2 meg.)		1/-
Do., and Condenser .0003		1/9
Empire Tape	doz.	9d.
Adhesive do.	roll	4d.
Earth Clips		7d.
Adjust	6d. & 7d.	
Washers, 2 and 4 P.A.	3 doz.	2d.
100,000 ohms Res.		1/6
Fine Variometers		2/6
Nugraving Set		7 1/2d.
Enclosed Detectors		11 1/2d.

WE PAY YOUR FARE AS FOLLOWS

UP TO 2/6 ON ORDERS OVER 20/-	
UP TO 5/- " " 40/-	
UP TO 7/6 " " 60/-	
UP TO 15/- " " £5.	

CERTAIN CUT LINES EXCLUDED.

"R" VALVES

Phillips	7/11
French Metal	6/11
Detecting Dutch	4/9
Dull Emitters, Dutch	11/9

No Post Orders.

ELECTRON WIRE

100 feet - - 1/8

Post 6d.

GECOSITE

(G.E.C.) - - 1/6

NICKEL - PLATED

Phone Terminals doz. 1/6

Pillar Terminals doz. 1/6

Post 3d. Doz.

Brown's Featherweight Headphones (Type A)

25s.

Beware of cheap throw-outs.

RIGHT OPPOSITE
DALY'S
GALLERY DOOR

K. RAYMOND
27, LISLE STREET, W.C.2

'PHONE: GERRARD 4637.

HOURS OF BUSINESS:
DAILY - 9 to 7.45
SUND, 10.30 to 1

“ Jones had a four-valve mind and a crystal income.”

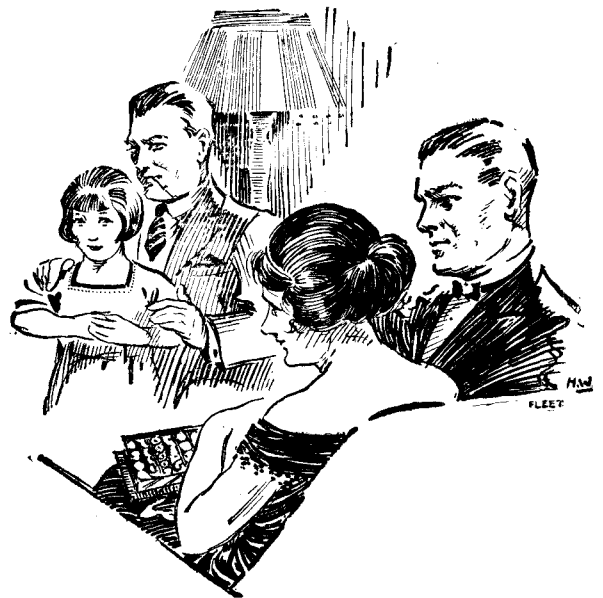
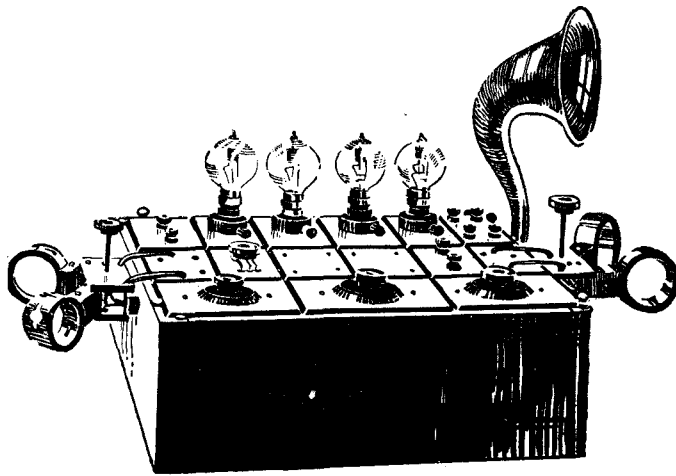

You can build this Four Valve set—

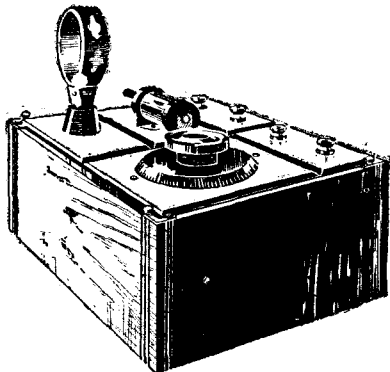

by starting with this Crystal Receiver.

USE THIS COUPON

Please send **POLAR BLOK BOOKLET**, for which is enclosed 5d.

Name

Address

POST TO-DAY

but where there's a will there's always

POLAR BLOK

ELASTIC SET CONSTRUCTION.

JONES wanted wireless too much to play patience until he could afford his ideal—a four-valve set. He wanted, at any rate, the London concerts *at once*, and did not see any sense in buying a rigid, ready-made, costly crystal set which would have to be scrapped later. Lucky day when he stumbled on Polar Blok. Of course he saw it at once—start with a set of crystal receiver parts and keep adding as you can afford until, “ Presto ” —a four-valve effort !

That was how Jones came to own the set illustrated above—built with standardised Polar Blok components and without any tools beyond a screwdriver and pliers. Jones is no engineer—he's a clerk in the City—yet he has nightly audiences of friends who enjoy the finest loud-speaker entertainment in the neighbourhood, from a four-valve set purchased on a crystal income.

You must get to know Jones' method—any Polar stockist will explain it, or you can get the Polar Blok book for 5d. by sending the coupon on your left.

RCC

RADIO COMMUNICATION

COMPANY, LTD.

34-35 NORFOLK ST. LONDON, W.C.2

(Cable: THE CENTRAL, 2480 (S. 1-11))

(Telephone: RADIO COMMUNICATION LONDON)

Branches:

NEWCASTLE 27 Collingwood St.	GLASGOW 123 Tiger Street.	CARDIFF Atlantic House, 57 Park St.	LIVERPOOL 41 Dale St.
			SOUTHAMPTON 15 Queens Terrace

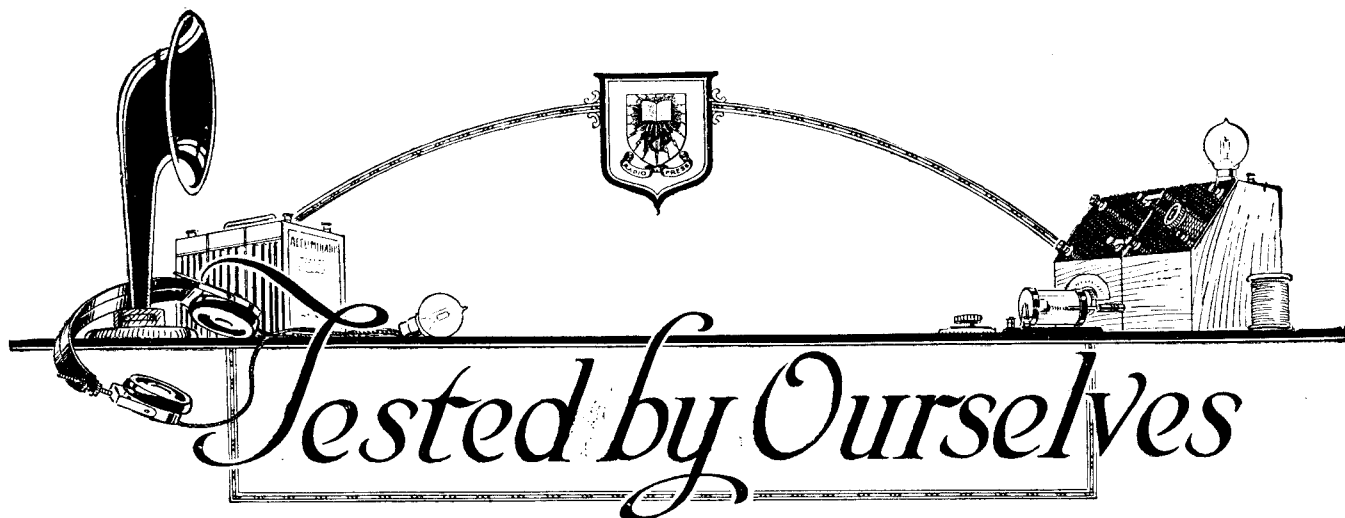

A Short-Wave Coil.

Messrs. Gambrell Bros., Ltd., have submitted for trial one of their short-wave plug-in coils, No. a₂.

This is uniform in outward appearance and mode of winding with their other coils which have been already noticed in these columns. The coil casing is 4 in. in diameter by about $\frac{3}{4}$ in. thick. The ordinary plug-and-socket fitting is provided, so that it plugs into the standard type of coil-holder.

On test in a conventional type of receiver, using standard R valves, with a .0005 μ F series condenser at its minimum value, and a No. 35 coil of usual type as reaction coil, it was not found possible to go down quite to 100 metres on a P.M.G. twin-wire aerial. Much amateur Morse below about 150 metres, and some telephony, was picked up at good strength. Favourable results were obtained by using Mr. Scott-Taggart's method of constant aerial tuning, using a very low minimum series condenser, and tuning by a .0003 μ F condenser in parallel with the inductance. With a No. 35 or 25 coil as reaction, best tuned by a very small parallel condenser, the circuit oscillated readily over the range from around 125 to over 150 metres, and C.W. Morse came in throughout this range.

Using this coil as a secondary coil, with a primary of five turns of No. 18 S.W.G., d.c.c., $3\frac{1}{2}$ in. diameter, fairly closely coupled to it, and about .0001 of a .0005 μ F variable series condenser in series with the primary (the secondary being tuned as before with a .0003 μ F variable condenser), it was possible to go just below 100

metres on the outside aerial. The circuit oscillated smoothly and easily with a No. 25 reaction coil and 60 volts HT. The powerful American station, K.D.K.A., came in quite comfortably readable on the loud-speaker on the two valves, though with the typical unsteadiness and distortion associated with this cross-Atlantic transmission. With but two valves in use, and with a single efficient silent stage of audio-frequency amplification beyond the detector-valve, "atmos-

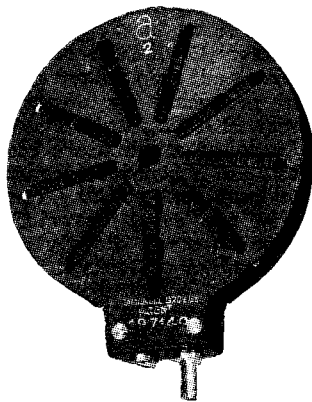

The Gambrell Short-Wave Coil.

pherics" were not extremely bad. Selectivity was not, however, a conspicuous feature, as the tuning was surprisingly flat, and a good deal of mush was included. The same was noticed in tuning-in amateur stations.

On an inside aerial on the first floor, about 7 ft. by 5 ft., K.D.K.A. was clearly readable (with headphones) on the two valves, rather better, in fact, than Newcastle comes in in London on the same aerial.

In view of the excellent design of these coils, and the really remarkably low distributed capacity attained with them, as the result of the wide spacing of the wire, it is a great pity that the makers have seen fit to depart from the accepted and experimentally well-established principles of short-wave work by ignoring the greatly increased H.F. resistance of wire at frequencies of 3,000 kilocycles or so, and winding their short-wave coils with such extremely fine wire. The effect on selectivity and ease of oscillation is very marked, and whilst by excessive use of reaction signals can be boosted up to some extent, with the flat tuning such an amount of mush and general interference is brought in, also enhanced in strength, that the effective signal-strength is disappointing.

Battery Charging Board.

Those who are fortunate enough to have direct-current lighting-mains in their houses will find interest in the "Ulinkin" home accumulator-charging instrument, a sample of which has reached us from the Gran-Goldman Service.

Whilst charging accumulators directly from the mains with a series resistance, whether in the form of lamps or otherwise, is a pretty expensive business, when the light or heat from the wasteful resistances is not otherwise utilised, by putting the 4 or 6-volt accumulator right in series with the whole lighting system of the house, so that all current drawn from the mains for domestic lighting, etc., passes through it, the charging can be carried out practically gratis, as it is at the expense only of a slight dimming of the lights or slowing-

down of the heating, etc., on account of the 5 to 8 or 9 volts lost in the accumulators out of the whole pressure of 110 or 220 volts in the mains.

The Ulinkin unit is adapted for this purpose: it is intended to be placed permanently in the house-circuit, near to the main fuse-boxes, and wired up in series with the negative main. A double-pole switch on the small board which makes up the unit diverts the lighting-current, at will, through a small ammeter (reading to 15 amperes), and to two terminals to which the accumulator on charge is to be wired; on turning off the current, it passes straight on to the house mains, without any interruption, and the charging terminals are isolated. In this way, provided sufficient current is ordinarily consumed in the household to charge the accumulator in the time—the makers suggest the use of two accumulators, one to be always on charge—and also that the whole current taken does not at times seriously exceed the maximum rating for the accumulator (which is hardly likely to occur in a house of moderate size, when no large motors or many electric stoves are installed) a steady supply of the essential "juice" can be obtained.

The instrument is neatly finished, and constructed in the style and conforming to the accepted standards of domestic electric fittings; on actual trial it proved quite effective. The small ammeter was noticed to give indications only when quite a respectable current was passing, which might possibly mislead the user, who would expect to see some reading when having but few lamps alight in the circuit. With the modern half-watt lamps on, e.g., 240 volts, this does not represent a very large current, though sufficient to charge a small accumulator if time enough be given.

"Ferrix" Transformer.

Messrs. Rose, Llycd and Co., Ltd., have sent for trial a sample

of their "Ferrix" transformers, for use on alternating-current house-mains, giving several amperes of alternating current at a low voltage, and taking about as much power as a small electric lamp. It is suggested that these may be useful as a source of filament-current supply for radio reception.

The instrument submitted was wound for 110 volts A.C., of 50 cycles and had two secondary coils, giving nominally three volts each, or 6 volts together.

On testing (necessarily it was actually tested on a 240-volt main with a lamp resistance in series) it was found to give several amperes at well over 6 volts under these circumstances, but warmed up considerably. A smaller pattern, which has been in the possession of the writer for some time, and has given every satisfaction, wound for 200-250 volts A.C., keeps considerably cooler in operation. The present sample was tested more particularly with a view to filament lighting.

Evidently there are encouraging possibilities in this direction for the application of these handy little transformers.

An Extra Resistance for D.E. Valves

A neat form of extra resistance for use when the new extremely low-consumption type of dull-emitter valve is adopted on a set designed for the older type of valve and for accumulators has been produced by Messrs. L. McMichael & Co., Ltd. This takes the form of a miniature circular adjustable resistance, controlled by a knob and rotating contact-arm in the usual manner, but adapted to screw directly on the L.T. terminal of the set, in place of the usual terminal nut, with a No. 4 B.A. thread. A small terminal on one side provides for the battery connection. It is thus placed in series with and supplementing the regular resistance. The value of this resistance was found to be approximately 24 ohms.

The fitting is well made and highly finished. It has a positive stop for "on" and "off," and showed on trial the desirable silent control and silky action.

A Two-Coil Holder

A sample of their "Reversine" coil holder for the standard type of plug-in coil has been submitted for test by Messrs. McMichael, Ltd. In this two-coil holder the one coil is held stationary in a vertical position in one plug fitting, whilst the other coil is withdrawn to a distance of 3¼ in. approximately, turning continuously the while so that it is now at right angles to the fixed coil (and therefore the coupling is zero); then it is brought back so as to practically touch the fixed coil, but this time in a reversed position. All this is performed by one motion through 180 degrees of a handle designed with a view to avoiding hand capacity effects by a simple mechanical device of a slide (on two brass rods which at the same time provide electrical connection) and a crank.

The instrument is 7 in. long, and the handle requires a clearance of 4 in. on each side at a height above the panel, etc., of about 2 in. The ebonite base is provided with four holes for fixing screws, if required.

On actual test, a very fine and complete control over reaction was observed, as well as the possibility of the closest coupling of the plug-in coils when required for supers, etc. The convenience of being able to reverse the reaction without changing any connections was very noticeable. The mechanical action was steady and positive, fine adjustment being readily possible, and it was quite silent in operation, the contact to the moving part being reliable. Finish and workmanship were excellent. We would have preferred to have the terminals a little less crowded for rapid changes of connections in experimental work.

LEADERSHIP!

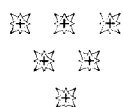

"WIRELESS WEEKLY" is famous throughout the world for its informative articles, critical editorials, and remarkable "how-to-make" features. Do you buy it?

SIXPENCE WEEKLY.

Edited by JOHN SCOTT-TAGGART, F.Inst.P., and the Radio Press Technical Staff.

PETER CURTIS LTD.

In conjunction with

THE PARAGON RUBBER MANUFACTURING CO., LTD.

AT

THE BRITISH EMPIRE EXHIBITION

The Palace of Engineering

Avenue 14..... Bay 12

WEMBLEY

EXHIBITS:

THE CURTIS ALLAFORT.

Combined Electric Gramophone and 5 valve Wireless Receiver. From **200 Guineas.**

THE CURTIS PEDESTAL CABINET.

Complete and self-contained with Loud Speaker, 4 and 5 valves. From **75 Guineas.**

THE CURTIS TABLE CABINET.

Complete with all accessories. 2, 3, 4 and 5 valves. From **20 Guineas.**

THE CURTIS OPEN PANEL MODELS.

Prices from **14 Guineas.**

RADIO-STRUCTA.

2, 3 and 4 valves. Prices from **5 Guineas.**

RADIONETTE CRYSTAL SERIES.

Prices from **12/-**

"NU - GRAVING"

Fine exhibit of this label marking process in many colours suitable for various purposes.

CRYSTOR COWL.

Aerial Insulators and Lead-ins.

"PARAGON" RADIO QUALITY EBNITE

in panels, sheets, rod and tube.

WIRELESS AND MAGNETO MOULDINGS

and comprehensive exhibition of all insulating materials.

VALVE HOLDERS AND COIL HOLDERS.

PARAFLEX.

The anti-capacity ebonite sleeving.

SOLE EXPORT AGENTS FOR JACKSON BROS.

"J.B." CONDENSERS. Complete range of all models.

PETER CURTIS, Ltd.,

34, Whitfield Street, London, W. 1.

Telephone: Museum 8489.

Northern Branch - - - 312, Deansgate, Manchester.

Telephone: Central 5995.

THE

POWQUIP

INTERVALVE

TRANSFORMER

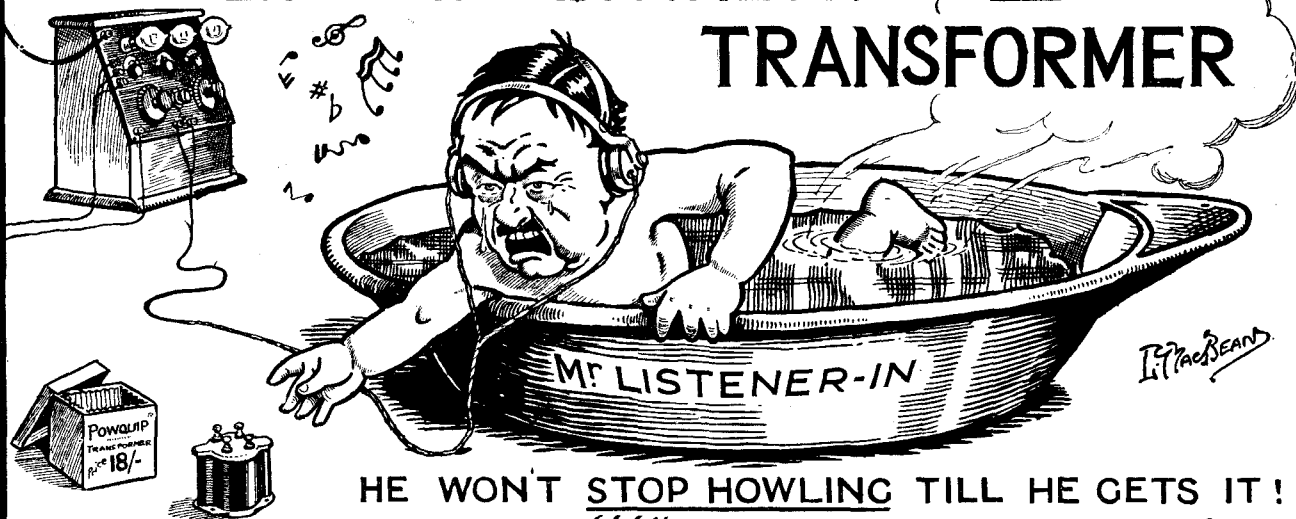

HE WON'T STOP HOWLING TILL HE GETS IT!

(With sincere apologies to "PEARS'SOAP.")

OF ALL DEALERS.

Ordinary Model price 14/6 each.
Shrouded " " 18/- "

THE POWER EQUIPMENT CO LTD Cricklewood, LONDON, N.W. 2.

USE BELLTONE CRYSTALS

SOLD WITH A
12 MONTHS' GUARANTEE

No. 1.—For use in Crystal Circuits or those employing L.F. amplification only. Special magnetic whisker included. Easily the Best Crystal yet produced. Price 3/6.

Will play a loud speaker if not more than 7 miles from the B.B.C. station. (Will any other crystal do this?)

No. 2.—Perikon Type. For use in any circuit, but specially recommended for Reflex sets. Employs neither Zincite nor Bornite. A new Belltone combination with a REMARKABLY LONG LIFE. Price 4/-.

Supplied in sealed boxes with 12 months guarantee and full instructions enclosed. Direct from

BELL LABORATORIES
23, Queen's Chambers,
Queen's Street Arcade,
CARDIFF.

Good Disc. to the Trade.



The Smile of Satisfaction

He knows "THE BEST IS CHEAPEST IN THE END." Do you



HELLESEN BATTERIES
are
ACKNOWLEDGED BY THE TRADE AS
"The Best in the World."
These are a few only of our standard types.



GENUINE HIGH DRY HELLESEN TENSION BATTERIES

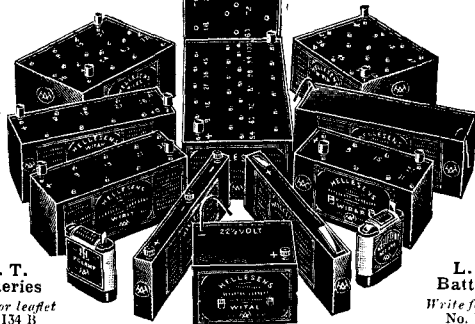

H. T. Batteries
Write for leaflet No. 134 B

L. T. Batteries
Write for leaflet No. 142 B

CODEWORD	VOLTS	DETAILS	PRICE
"WIRAY"	9	Grid Battery	2/3
"WIRIS"	15	"	3/9
"WIRON"	15	H.T. Battery 4 1/2 v. tappings	3/6
"WIRIT"	36	"	8/6
"WIRIN"	60	"	14/-
"WIRUP"	99	"	23/-

NOTE—Prices include 1 Red and 1 Black Wander Plug.—NOTE ALSO A COMPLETE RANGE OF L.T. BATTERIES FOR EVERY CONCEIVABLE USE.

PLEASE NOTE WE ARE NOW ABLE TO DELIVER **FROM STOCK**

Croydon 2225. **A. H. HUNT, LTD.** "Keyage, Croydon."
H.A.H. WORKS, TUNSTALL ROAD, CROYDON.

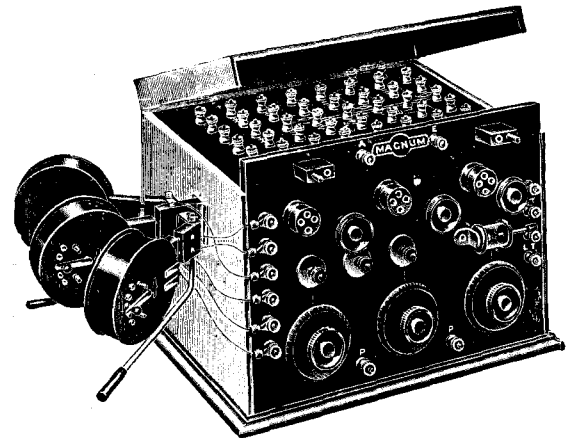

The wonderful OMNI, as illustrated 18 Guineas.
AS SUPPLIED TO THE ALGARSSON ARCTIC EXPEDITION.

Receives everything from everywhere.

We specialise in High Grade Components. Send stamp for list and set of leaflets dealing with the **OMNI, ST 100** (No. 1 Envelope), **ST 100 Star Family 4-Valve** (No. 2 Envelope), **3-Valve Dual**, and various circuits described in **MODERN WIRELESS**, "Wireless Weekly," R.P. Envelopes and Handbooks.

Radio Press Envelope No. 1 ST 100	1/6	post 2d.
Radio Press Envelope No. 2 Family 4-Valve	2/6	" 2d.
Magnum Choke for ST 100 Star	7/6	" 6d.
Omni Connecting Links, per set of 50	8/0	" 4d.
Magnum 3-way Coil Holder	12/6	" 6d.

Recommended Components for Constructing the **3-Valve Distortionless Receiver**, as described in this issue by Mr. Percy W. Harris.

Polished Mahogany Cabinet, 14 by 8 by 4	£	s.	d.
Ebonite Panel, Squared and Matted	12	0	0
Ebonite Panel; Squared and Matted, Drilled and Engraved	7	0	0
Square Law Condenser .0005, complete with Calibration Chart and Drilling Template	17	0	0
Magnum 2-Coil Holder	9	6	0
Watmel Var. Resistance, 50,000-100,000 ohms	3	6	0
Watmel Var. Grid Leaks, 5-5 megohms	2	6	0
Microstat Filament Resistance	2	9	0
Fixed Condensers, guaranteed capacity .0003	1	3	0
H.T. Condensers, .25	3	9	0
Terminals (Lacquered); complete	2	0	0
Tinned Copper Wire, per yard	1	0	0
Magnum Tapped Coils No. 1, 180-1,000 metres	12	6	0
Magnum Tapped Coils No. 2, 600-2,600 metres	15	0	0
Magnum Concert Coils, Ebonite cased, per set of 4	1	5	0
Myers Valves	12	6	0

Carriage and Packing free on orders value £2 or over.

We can supply components for all circuits described in this issue.

BURNE-JONES & Company, Limited.
Radio Engineers,
MONTFORD PLACE, KENNINGTON, LONDON, S.E.11.
'Phone: Hop 6257.

Experimental Stations
(200 metres):—
2 FP New Cross.
2 PB Kennington.
2 CT Lambeth.
6 CW Streatham.



CABINETS YOU WANT

PICKETT'S Cabinets—they're good value, from 1/6 each, highly polished. Cabinet Works, Albion Rd., Bexley Heath, S.E.1. Write for Lists M.W.

Better H.T.'s and Cheaper!

H. T. Batteries made up of units are recognised as the ideal.

The HOVIMO screw connection solves the problem of joining units without soldering.

The HOVIMO assures perfect "sil ent" working—is everlasting—allows easy replacement of units—will take the ordinary wand r plug—makes it possible to keep your H.T. at an equal voltage. Is British made.

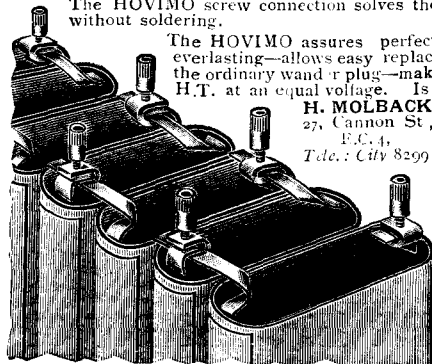

H. MOLBACK
27, Cannon St.,
E.C.4,
Tele.: City 8299.

Ask your dealer for them.

1/6

Per Doz.
From dealers or direct from me

PLUG HOLE



GRIP

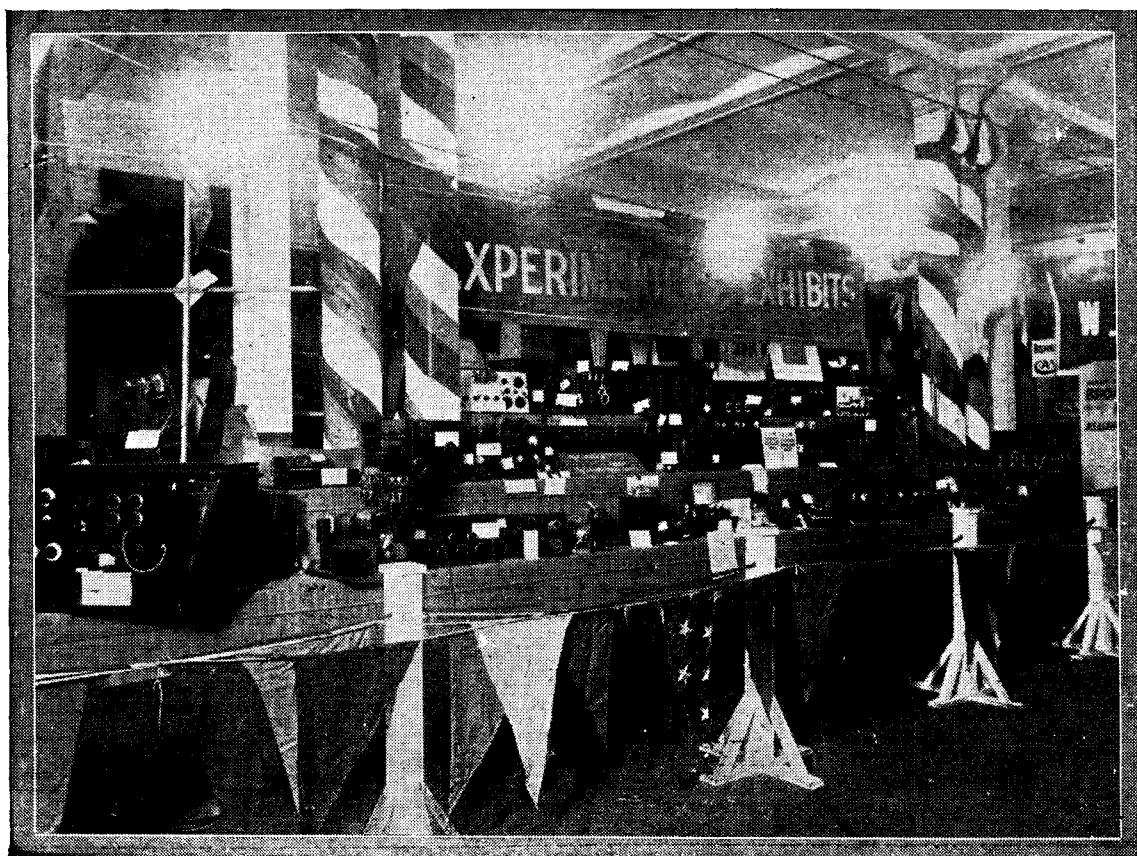

The stall of the Wireless Institute of Australia (N.S.W. Division) at the recent exhibition referred to below.

An Australian Wireless Exhibition

To the Editor of MODERN WIRELESS.

SIR,—On behalf of the Council of the Wireless Institute of Australia (N.S.W. Division), I am forwarding a photograph of one side of the Experimental Stall at the recent Wireless and Electrical Exhibition, also copy of the catalogue and *Radio*, our official magazine, in which appears the full account, as passed by the Council, of the Exhibition.

The N.S.W. Division of the Wireless Institute of Australia is the oldest experimental wireless body in the British Empire.

The attendance at this exhibition reached just over the 12,000 mark in the week, and many complimentary remarks were passed on the experimental stall, which was made up almost entirely of amateur workmanship, even in some cases to the lathe and bench work, including knobs, dials, switches, etc. Among the visitors who were interested in the exhibits,

some came from Hong Kong, Great Britain, and America.

Broadcasting, from a commercial point of view, has only just commenced in this country, this being the only State, so far, in which "sealed sets" are being used by the "listeners-in." The tests which have been carried out by the first company in the field are now drawing to a close, and the reports have proved very satisfactory, the last being reproduction from the theatre over land line to the studio and transmitting station about 5 miles away.

Our main drawback is in the country districts, on account of there being so few experimenters beyond a certain area, and in some parts 100, 200 or 300 miles separate two experimenters, which can only be overcome by each working a transmitting as well as receiving station.

The Government department controlling wireless is always considering very favourably genuine

experimenters, especially the country ones, and we hope shortly to have the Australian Radio Relay League in full swing, as it has been formed some few months now.

The American experimental stations have been copied on various occasions by our experimenters, and New Zealand working is a nightly occurrence on 5 watts for transmitting; in working New Zealand a considerable amount of fading in signals has been noticed. Originally howling valves caused a considerable amount of annoyance, but now the new regulations forbid the use of a regenerative circuit within 50 miles of a commercial or broadcasting station, except under special circumstances.

For transmitting, no spark transmission is allowed within 5 miles of any commercial or defence stations; valve allowed with maximum anode current of 10 watts and I.C.W. in certain cases.

Five to 50 miles distant, any

system of transmission with power not exceeding 25 watts; over 50 miles any system with power up to 250 watts. The experimental licence is 10s. receiving, and 10s. transmitting, per annum; no restrictions on aerial, shape or size.

Our president, one of the oldest of Australian experimenters, is hoping to fit out a complete set and separate aerial on board s.s. *Tahiti* early this year, and carry out experiments between Australia and America, copying each amateur Australian, and comparing audibility readings, etc.

Finally, I hope that you will be able to find after reading through this and the accompanying papers that the experimenters are being backed in various parts of the British Empire, not only by various Governments, etc., but also by a common comradeship and general wish "to help the other man," and although 13,000 miles or so separates us, a publication such as yours not only helps to fill that gap for the time being, but gives us month by month the best of results obtained by our friends in Great Britain. The copies have been coming to me through an Australian who went to visit England and the

Continent, and now I watch for the copy each month to hand.

Yours faithfully,
H. RIGBY GREGORY.

Member of Council of Wireless Institute of Australia (N.S.W. Division).

Abboisford Pt.,
N.S.W., Australia,

**Positions for all
Wireless Operators**

To the Editor of MODERN WIRELESS.
Sir,—With reference to the article published in your journal in January last, there appears to be an erroneous statement with regard to wireless operators. In the second paragraph it is stated, *inter alia*, that the approximate surplus of operators over actual requirements is 2,898, and in the following paragraph it states that the number of unemployed persons holding the P.M.G. First-Class Certificate approximates 1,800. If these figures are accurate we fail to reconcile the number of unemployed with the surplus, as

you will observe there is a difference of no less than 1,000. One naturally asks what has happened to the latter number?

We would also like to ask, through the medium of your journal, whether the figure of 1,000 wireless operators being unemployed can be substantiated. We ask this question definitely as it does not seem to us to be supported by the actual conditions now prevailing in the employment of wireless operators. For some months past we have had no difficulty whatever in obtaining employment for all students who obtained the Postmaster - General's certificate trained at our schools, and we can further state that there is no difficulty whatever in obtaining positions for all future students who obtain the said certificate.

We respectfully ask you to publish this letter, as under the present circumstances the article is certainly misleading.

Yours faithfully,
On behalf of the British School of Telegraphy, Ltd.,
JAMES H. WEBB, Manager.
J. R. SCHOFIELD, Conductor.
Principal: Wireless Colleges Cardiff and Bournemouth.

YOU SAVE 33 1/3% ON ALL WE ADVERTISE

FILOSTAT for D.E. VALVES 2/6	BASKET COIL HOLDERS 1/3
0 to 30 ohms.	VARIOMETER BALL 3/6
CABINET AND EBONITE PANEL, 6 in. by 6 in., each 6/-	ROTOR 3/6
VARIABLE CONDENSERS .031 8/6; .0003 5/6; .0005 6/-; .000757/6	DIAL & KNOBS, 7d., 10d., 1/-
FILAMENT RESISTANCE 7 ohms 1/6	SWITCH ARM, 1st quality 9d.
Phones, 4,000 ohms .. 12/6	TRANSFORMERS H.F. PLUG-IN TYPE. Ranges from 150 to 5,000. 3/6, 4/6, 5/- & 6/- each.
L. F. TRANSFORMER Energio 12/6	COIL HOLDERS. 1 way 1/-
VARIOMETER 2/6	2 " 4/6
	3 " 5/6

Ask for our price list C. of British Made Components and you will save money.

Mail Orders Only. Postage 1d. in the 1/-. Special Terms to the Trade.

RADIO MAIL ORDER CO.,
5, UPPER CHARLES STREET, LONDON, E.C.

BEWARE OF WORTHLESS IMITATIONS, SEE THE TRADE MARK *Watmel* ON EVERY GRID LEAK.

WATMEL VARIABLE GRID LEAK
(Patent No. 206098)

Constantly Variable.
Silent in operation.
Constant in any temperature.
Dust and Damp proof.
Each tested and guaranteed.
Neat and well made.

GRID LEAK .5 to 5 megohms 2/6.

ANODE RESISTANCE 50,000 to 100,000 ohms 3/6.

Suitable for S.T. 100 Circuit.

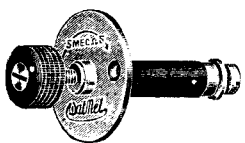

SEND P.C. FOR DESCRIPTIVE FOLDER.

WATMEL WIRELESS CO., Connaught House, 1a Edgware Road, Marble Arch, W.2. Tel. 4575 Paddington



The *Fynetune*

Gives HAIRSBREADTH ADJUSTMENT TO CONDENSERS ETC. Three Minute - One Hole Fix

YOU can get the Distant Stations

DON'T fix a fishing rod on your condensers—Fit a "FYNETUNE." It gives absolute micrometer control and enables you to get—and hold—the distant stations.

THE LATEST AND MOST EFFICIENT VERNIER ADJUSTER.

ELIMINATES THE TROUBLESOME HAND CAPACITY EFFECTS.

THE KNOB ROTATES IN SAME DIRECTION AS CONDENSER KNOB.

Can be obtained from most Live Wireless Dealers or sent direct for **2/6** and your dealer's name and address.

Sole Distributors—

SPARKS RADIO SUPPLIES,

43, GREAT PORTLAND STREET, LONDON, W.1. Telephone—Langham 2463.

OTHER GOOD LINES—"Radiohm" Bus Bar $\frac{1}{16}$ square Tinned Copper, 2/- doz. Postage 3d. "Radiohm" Ribbon Aerial. Helps you across the Atlantic. 100 feet on reel, 3/- Postage 5d.

(Continued from page 756)

currents; you will remember that a pencil line is sometimes used as a gridleak. The next process is to cut along the scribed line, using a stiff-backed saw for the purpose. Lay the panel flat upon a piece of wood placed upon the bench, wedging the edge opposite to you against a stop, which may be made from a length of hard wood screwed to the bench. Hold it tightly,

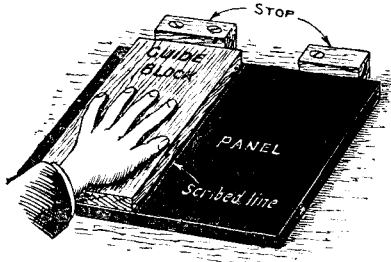

Fig. 2.—A useful guide.

down with the left hand. Make a careful cut along the scribed lines, beginning at the end nearest to you. When this cut is just deep enough to hold the saw blade, make another at the opposite end of the line. The saw may now be held level, care being taken to see that it is working in the two guide-cuts made. It simplifies matters if a straight piece of wood is placed on

top of the panel and held tightly with the left hand so that one of its edges follows the scribed line (Fig. 2). It will then act as a guide for the blade and will prevent it from marking the ebonite if it should happen to slip. It is sometimes stated that the hacksaw is the best tool for cutting ebonite; it certainly does the work very quickly; but for edges the tenon saw is to be preferred, since it is so much easier to keep it straight.

We have now three edges at right angles to one another. It remains only to make the final cut. This we do by using either AC or BD as a reference and marking out the line CD with a setsquare.

Now comes the business of trimming up the edges. Place the panel in a vice whose jaws are cushioned by strips of sheet lead bent over them. (Use a plain steel jawed vice and you will make the most unsightly marks upon the ebonite.) With a fine file smooth down each edge in turn; then give it a final working with the handy little tool shown in Fig. 3, which has the effect of rounding it off very slightly at the upper and lower surfaces. To obtain the best finish use old worn emery cloth and damp the ebonite with turpentine. The panel is marked out for drilling with the aid of setsquare, dividers,

scriber and centre punch. When the holes have been made in their proper positions, treat the surface on both sides with fine worn emery cloth and turpentine. The purpose of this is to remove the glossy finish, which, though beautiful to look upon, is apt to impair the insulating qualities of the material. High-frequency currents travel only upon the skin, and the glossy surface of ebonite has often quite respectable

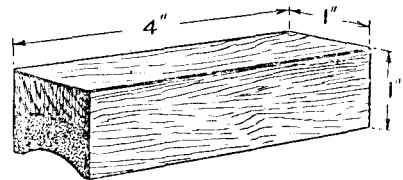

Fig. 3.—A rounding tool.

conducting qualities. It is produced in some cases by pressing the ebonite between sheets of tinned iron. In the process a certain amount of the tin is apt to be pressed into the ebonite, and if it remains it provides a path of low resistance for current. Treated with emery and turpentine, the panels assume a dead black dull finish, which looks extremely well and does not in any way impair the efficiency of the material as an insulator.



Ethovox REGD

The Perfected Loud Speaker.

BURNDEPT
WIRELESS APPARATUS

Value for Money

A Full Sized Loud Speaker



AN increasing demand for the "Ethovox," the world's best loud-speaker, has made possible a substantial saving in the cost of production. This saving we have pleasure in passing on to the public as a reduction in price.

The "Ethovox" is a superb musical instrument, reproducing speech and music purely and clearly. Its technical perfection is backed up by a twelve months' guarantee given with each instrument. The fair and graceful swan-neck are a rich mahogany colour—not black. At any of our Branches or Agents you can hear the "Ethovox" in operation.

Full-size table pattern, height 26 in., either Low Resistance, 120 ohms (No. 203), or High Resistance, 200 ohms (No. 204)—Price £ 5 0 0.

BURNDEPT LTD., Aldine House, Bedford Street, Strand, W.C.2.

PHONE: Gerrard 9072.

Readers' Results

Some interesting letters from readers about the Reinartz and other sets.

To the Editor of MODERN WIRELESS.

SIR,—As a regular reader of your valuable periodical, I should like to pay a tribute to the description of a Reinartz Circuit, as described in the March issue. Using only 2 valves, Ora detector, and French "R" as L.F., I am able to work the loud speaker comfortably on Manchester, twenty miles distant, and last evening received Bournemouth's relay on the L.S., in a full-sized sitting-room. Any of the other stations come in quite well on the 'phones. Even in daylight, which, when taking into consideration that the aerial is only twenty odd feet high, is very good. Even without aerial and using earth alone, Manchester is louder than on a crystal set.

The coil is wound with 20 S.W.C., D.C.C., on a wooden former,

not shellacked or insulated in any way, and a turn or two extra is wound on the aerial coil, as I am using a .0003 condenser in place of the .0004 as stipulated.

Thanks to Mr. Harris, I have found a quiet, easily worked, and very efficient circuit which will repay the small amount of trouble spent on it. Yours faithfully,

H. MARTLAND.

Collins Green,

Ny. Newton-le-Willows, Lancs.

To the Editor of MODERN WIRELESS.

SIR,—Forgive me writing to you, but I must thank you for the wonderful circuit which you have given on page 423 of the March MODERN WIRELESS.

I try out regularly each circuit in this periodical as it comes out on a 6-valve experimental panel board, and I have never found one

with such ease of tuning, clarity of L.S. tone, and being able to obtain every broadcasting station in U.K. in about half a minute.

At Feltwell it is particularly difficult to tune at all, and then only one or two stations come in, partly, I think, owing to its proximity to the expanse of Fen land with water around to the west.

I can get a L.S. quite well (Junior Amplion) on two valves, which I should think is a record, being about 130 miles from London, and with two stages of L.S. the whole lot of the stations are very loud and phones unbearable. I know what loud means, as I have had five valves going with both H.F. and L.F. transformers and three coils working.

I have wired direct from circuit diagram No. 5, and not from your completed panel.

FINE RESULTS FROM FINE COMPONENTS

Where FALLON products are used there are no failures

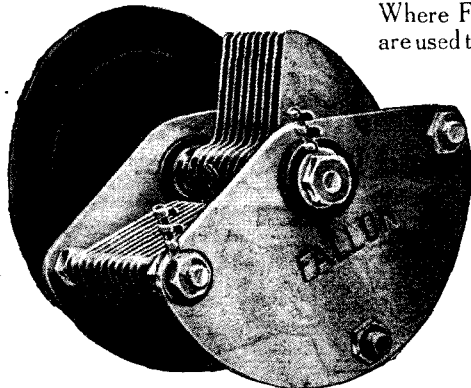

This is our NEW Model A II Condenser

right up to FALLON standard and will appeal to thousands of constructors who prefer the following points, which are included in same:—

One Hole Fixing.
Tag Connections.
Heavy Aluminium Top and Bottom Plates.

The Best, and nothing but the Best, British material and workmanship are put into this New Fallon Condenser. Metal-to-Metal adjustable bearings. Stout, well-cut, aluminium vanes. Complete in every respect and exactly as illustrated.

	Plates.	Price.		Plates.	Price.
.001	57	8/-	.002	13	4/6
.0005	29	6/-	Vernier	5	4/-
.0003	19	5/6	Vernier	3	3/6
.00025	15	5/-			

For those who prefer it we still supply our well-known A II. model, which is exactly the same as the above, except that instead of having aluminium ends it has composition ends and is supplied with our special feature, the Aluminium Screening Disc, which disc is also supplied with the model above illustrated.

STOCKISTS EVERYWHERE.—Every FALLON article carries our money-back guarantee. Insist upon your local dealer supplying you with FALLON products. If he will not, send cash with order direct to us. The name FALLON guarantees satisfaction.

FOREIGN AND COLONIAL AGENCIES.

Australia.—THE WESTRALIAN FARMERS, LTD., PERTH, W.A. (NATAL, South Africa.—G. D. HENDERSON & CO., 15, TIGER STREET, MARITZBURG, STUTTAFORD & CO., LTD., JOHANNESBURG AND CAPE TOWN.

Sweden.—GRAHAM BROS., STOCKHOLM.

Holland.—DE WITT SADEE & CO., 152, DE CARPENTIER-11AAL, THE HAGUE.

WRITE DIRECT FOR TRADE TERMS

FALLON CONDENSER CO., LTD.,
WHITE RIBBON WORKS, Broad Lane, N.15

Phone: Tottenham 832

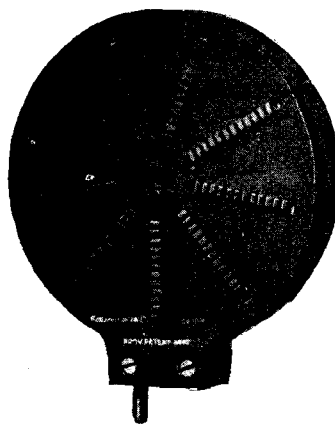

TO REMIND YOU

that the "Efficiency Inductance" is still the best on the market. Compare the list below with those published for other coils.

Coil.	Wave-length range shunted with .001 capacity condenser.	Self-capacity in Microfarads.	Price.
a	75 to 330	.000004	5/9
A	120 " 525	.000004	5/9
B	200 " 855	.000005	6/-
C	285 " 1200	.000006	6/9
D	400 " 1700	.000006	8/-
E	690 " 2875	.000008	9/6
F	1040 " 4350	.000009	10/3
G	1575 " 6800	.000011	12/-
H	2250 " 9500	.000014	14/-
I	3425 " 14500	.000017	16/-
J	5900 " 25000	.000021	19/-

GAMBRELL Bros., Ltd. 76, Victoria St., S.W.1.

West End Agents:
J. V. MULHOLLAND,
4, Blenheim Street, Bond Street, W.1.

(entrance in Palace St.)
Phone
Victoria 9938.

Manufactured
Entirely by
British Labour
in our own works.

The SECURITY BEHIND BONTONE



4,000
OHMS
PER PAIR

14/6

Post free

GUARANTEE. We agree to replace or return cash if Phones do not give complete satisfaction, subject to Phones being returned to us within 7 days of purchase, undamaged.

Have you recognised all the better qualifications which make BONTONE the distinctive type?

Mainly, they are backed by a most generous guarantee. Sensitive! Why? Simply that the magnets are made in our own works under our own supervision. BONTONE will respond to the weakest signals.

Durability? BONTONE are made of the best materials procurable, and their beautiful finish is highly creditable to skilled craftsmanship. Comfort? Throughout exhaustive tests we have worn BONTONE and know comfort a point mechanically successful. BONTONE are easily adjusted.

See you buy BONTONE GENEROUSLY GUARANTEED.

If you prefer lightweight, use BONTONE LIGHTWEIGHT 15/6 post free. These Headphones are similar in construction to the standard BONTONE, and are guaranteed.

Insist on receiving BONTONE. If your dealer cannot supply, send direct giving your dealer's name to:

B. D. & Co. (Edward A. Boynton)

Offices: 167-173 Goswell Road, LONDON, E.C.1.

Works: Goswell Rd. & City Rd., LONDON, E.C.1

Admiralty, War Office and India Office Contractors.

Sole Distributing Agent for Scotland: J. W. Gordon, of 98, Sauchiehall Street, Glasgow.

A Valve for Every Wireless Circuit



You wouldn't

be satisfied to overload a one-horse-power engine to try and make it give ten-horse-power.

Don't use ordinary bright filament valves to give you loud-speaker volume; use

THE NEW D.F.A.

the Mullard dull filament MASTER valve, specially designed to give volume without distortion.

If you have bright filament valves working on 4 or 6 volts, replace the last valves with D.F.A.s—you will be delighted with the increase in volume and clarity.

The same battery will do and it will last you longer.

D.F.A.s are new dull filament amplifying valves made in two types—the D.F.A.1 for 6-volt batteries, and the D.F.A.2 for 4-volt sets, as follows:—

	D.F.A.1.	D.F.A.2.
Filament volts	5.5	3.3
Filament amps.	0.23	0.25
Anode volts	50-100	50-100
Negative Grid volts	2-6	4-8
Price	35/-	30/-

Ask your dealer or write to us to-day (Dept. M.W.) for leaflet V.A.3, giving full particulars.

Visit our stand: British Empire Exhibition, Avenue 14, Bay 13.

Mullard

THE MASTER VALVE

Advt.—The Mullard Radio Valve Co., Ltd., Nightingale Works, Nightingale Lane, Balham, S.W. 12.

131

M. H. CONDENSERS

IDEAL for the experimenters and home constructors.

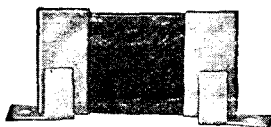

This type of flat condenser was and is our standard. It is efficient, reliable, easy to fix, and can be rapidly interchanged. The price is the cheapest, for a good condenser, on the market.

Standard M.H. flat type, fixed condenser with clips, any value, 0.001 μ F to 0.009 μ F, 1/4. 0.01 μ F to 0.002 μ F, 2/-.

Write for List of Shop Soiled Bargains.

L.M. MICHAEL LTD

IN CONJUNCTION WITH B. HESKETH LTD

Showrooms: RADIO CORNER, 179, STRAND, LONDON, W.G.2.

All correspondence to Head Office:

HASTINGS HOUSE, NORFOLK STREET, STRAND, LONDON, W.G.2.

THE MARK OF MERIT on any Wireless Set or Component is a guarantee of efficiency reasonable price, and sound British Manufacture.
BUY BRITISH GOODS ONLY.

Visit our stand at the BRITISH EMPIRE EXHIBITION (Electrical & Allied Engineering Section)

Complete catalogue over 30 profusely illustrated pages post free 1/4.

B.T.H. Radiola Wireless Sets

The surrounding pictures and appended details cover practically the complete range of B.T.H. Radio apparatus. All sets and accessories bear the B.T.H. monogram—the sign of perfect reception.

A.—Radiola Bijou Crystal Set.
Price including one set of 4000 ohm Headphones ... **£3 10 0**
B.B.C. Tariff, extra ... **1 0**

B.—Radiola Crystal Set (Model A). Price including one set of 4000 ohm Headphones **£4 15 0**
B.B.C. Tariff, extra ... **1 0**

C.—Radiola I. Valve-Crystal Set with H.T. dry battery. Price including one set of 4000 ohm Headphones, 1 B5 Valve and H.T. Battery ... **£11 0 0**
B.B.C. Tariff, extra ... **6 0**

D.—Radiola II. Self-contained Two-Valve Set with H.T. and L.T. Dry Batteries. Price including 2 B5 Valves, H.T. and L.T. Batteries, and one set of 4000 ohm Headphones ... **£21 0 0**
B.B.C. Tariff, extra ... **15 0**

E.—Radiola III. Three-Valve dry battery Set with self-contained Loud Speaker. Price including

H.T. and L.T. Dry Batteries, 3 B5 Valves and one set of 4000 ohm Headphones ... **£50 0 0**
B.B.C. Tariff, extra ... **1 0 0**

F.—B.T.H. Loud Speaker.
Form C.1. Price complete ... **£3 0 0**

G.—B.T.H. Loud Speaker.
Form C.2. Price complete ... **£5 5 0**

H.—B.T.H. R Type Valve.
0.05 amps. Price ... **12 6**

I.—B.T.H. B5 Type Valve.
0.05 amps. Price ... **£1 10 0**

J.—B.T.H. B4 Type Valve.
0.25 amps. Price ... **£1 15 0**

K.—B.T.H. Unit Amplifier.
Form A. Price ... **£3 5 0**

L.—B.T.H. Headphones.
4000 ohm. Price ... **£1 5 0**

The British Thomson-Houston Co., Ltd.

(Wholesale Only)

Works: Coventry. Offices: Crown House, Aldwych, London, W.C. 2.

Sole Agents for the Music and Gramophone Trades:—

THE MURDOCH TRADING COY.,
59 & 61, Clerkenwell Road,
London, E.C. 1.



2157

May I add that the wire used was No. 26 d.c.c., and not 22, as I have none.

I should be glad to have a line from you, as I am anxious to know if you will kindly give suitable coil wirings for waves from 700 m., 1,250 m., etc., etc., and to know if one could possibly make a series of such Reinartz coils to switch in at will.

Apologising you for any trouble. With many thanks,

Yours very truly,
 PHILIP W. NEIGHBOUR,
 M.A., M.R.C.S., L.R.C.P.

Brandon, Norfolk.

To the Editor MODERN WIRELESS.

SIR,—I feel that I must write and congratulate Mr. Harris on the really wonderful set described in MODERN WIRELESS, *i.e.*, the Reinartz-Chapman set. On Monday I roughly made up a coil and crudely wired up a panel with one valve. The results were surprisingly good, and I picked up in addition to all B.B.C. Stations, another station on 470 metres, apparently German, but it may have been one of the Swedish stations, although many words were similar to German words.

I subsequently put the coil and panel into my wireless cupboard, again very crudely wired, with most leads at least a foot long, and attached it to a two-valve amplifier. I did not trouble to remove the condenser across the first transformer primary, but put a 300 coil as H.F. choke.

The results are really extraordinary. Manchester, Newcastle, Bournemouth, Brussels, Cardiff and Paris are only a fraction less loud than London, and are in normal conditions audible 100 yards from loud-speaker, and every word intelligible at 25 feet. I am screened pretty badly by Epping Forest, being right in the forest, in a valley.

Mr. Harris is certainly modest in his claims for this set. The results are nearly as good as on a five-valve set (two H.F.'s with the Neutrodyne transformers). I have tried numerous circuits during the past year, generally with pretty good results, but this beats the lot easily.

I find Weco-valves give best results on this set, and in fact, as a detector or L.F. valve, I prefer them to any.

I get purer results and more strength from three valves than any set I have heard using four

valves. The Savoy band is audible 300 yards from the house with the windows open. I use large condensers almost everywhere, and resistances across transformer secondaries for good tone, and still volume is almost too great.

By the way, cannot something be done to stop the Morse nuisance. All this afternoon and evening there has been a station working on exactly 385 metres. It is sharply tuned, and is lost on 10 metres either way.

Yours faithfully,
 F. G. SACHETT.

Theydon Bois,
 Essex.

To the Editor MODERN WIRELESS.

SIR,—I have tried out your "Double Dual" Circuit and as requested in your article report results on it. We are 60 miles from London, and I find it an excellent loud-speaker circuit, and without any intentional reaction considerably more powerful than when the ST100 is using reaction. In my opinion it is quite as good as 1HF, D & 2LF with tuned anode and reaction on the anode. The signals come in with a rather quieter background than the ST100. I used variometers for the anode tuning

Silvertown

WIRELESS ACCESSORIES

Quality guaranteed by over 50 years' electrical manufacturing experience.

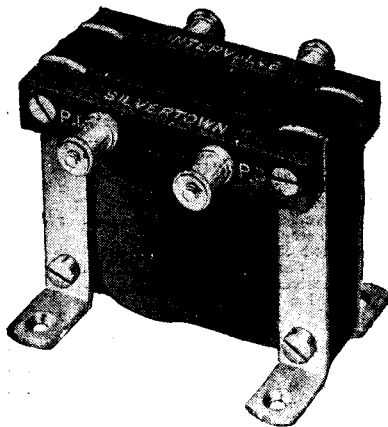

The only
 transformer
 with a
 12 months'
 Guarantee.

SILVERTOWN INTERVALVE TRANSFORMERS

This apparatus is specially recommended, and is giving great satisfaction to users in all parts of the world. The utmost care has been taken during manufacture to ensure perfect insulation and low self-capacity. This transformer can be used in power amplifiers, with pressures up to 250 volts. It also gives maximum amplification without distortion, and is absolutely noiseless in operation. Price 21/- each.

SAY 'SILVERTOWN' TO YOUR DEALER WHEN BUYING

Telephone Headpieces, Crystal Holders & Buzzers,
 Fixed Mica Condensers.

Filament Rheostats & Potentiometers, Insulators,
 Variable Condensers, etc., etc.

Makers: THE SILVERTOWN CO.,

106, Cannon Street, London, E.C. 4.

Works: Silvertown, E. 16.

RIFANCO 'PHONES AND PARTS.

4,000 Ohms tested
Headphones 11/6 pair,
Cabinets, Pedestals,
Sideboards, Accessories
for Wireless and gramophones,
Motors cheap.
32 page Catalogue 2d.
The REGENT FITTINGS
CO. (M.W.), 120, Old St.,
LONDON, E.C.1. Est. 20
yrs. Tel. Clerkenwell 2923

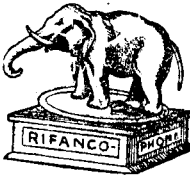

What is Reaction?

THE whistling sound of an oscillating set is familiar to you—perhaps you have even suffered from your neighbour's set. But do you really understand what Reaction is? There have been plenty of articles about Reaction in all the Wireless Magazines, but practically none of them ever go so far as to explain its true meaning and how it is produced.

In "Wireless Valves Simply Explained," however, the author takes great pains to clear up this and all other technical difficulties which are so often glossed over. Buy a copy to-day—you'll enjoy reading it.

"Wireless Valves Simply Explained"

By JOHN SCOTT-TAGGART,

F.Inst.P., A.M.I.E.E.

(Editor of *Modern Wireless* and *Wireless Weekly*.)

Contents

- The Theory of the Thermionic Valve.
- The 3-Electrode Valve and its Applications.
- Cascade Valve Amplifiers.
- Principles of Reaction Amplification and Self-oscillation.
- Reaction Reception of Wireless Signals.
- Continuous Wave Receiving Circuits.
- Valve Transmitters.
- Wireless Telephone Transmitters Using Valves.
- Broadcast Receivers.

2/6

From all Booksellers, or 2/8 post free direct:

RADIO PRESS, LTD.,

DEVEREUX COURT, STRAND, W.C.2.

Radio Press Wireless Library, No. 9.

G.R.C. (General Radio Company), for the first valve and a Sterling for the second, the Sterling with rotor and stator in parallel and secondary of Lissen Transformer as a choke. Aerial tuner—coil and condenser in parallel. For some reason a second G.R.C. gave much inferior results.

A peculiarity was that a howl accompanied the use of a Bornite-Zincite detector except with very carefully chosen spots, and there was no similar howl using Hertzite. Talite, which I had found even better than Hertzite with the ST100, was almost as bad as the Perikon. I could get only very feeble results on substituting a variable resistance for the choke coil. I made no attempt to use reaction, as the strength was sufficient for any loud speaker and I think it would make the circuit too difficult to handle.

Yours faithfully,

J. H. MINETT.

Borstal Hill, Whitstable.

P.S.—I find a Cossor P1 by far the most serviceable valve in Reflex Circuits and particularly so in this "double dual."

To the Editor of MODERN WIRELESS,

SIR,—I have just completed your "Double Dual" Circuit, and now, after seven days' trial I should like to let you know how pleased I am, and what results I have obtained with it. First let me tell you I am only an "advanced novice," if you can understand such a phrase; at any rate, I have only had a few months' experience with valves. I built your S.T.100 with good results, but dismantled it to try the "double dual." Local broadcasting good, but not as loud as on the S.T.100. All other B.B.C. stations can be heard on 'phones, but not loud enough for comfort on loud-speaker; beautiful and clear, and can cut out the local station on most. Now for my best achievement: I must tell you that I have never received any station outside this country before. Now I can get Eiffel Tower when the local station is on, about same strength as other B.B.C. stations; Ecole Supérieure, Paris, I get about the same; but Birmingham cuts "her" out when it starts. Best of all, however, last Saturday night I made up my mind to try all night for America, and started at one o'clock; but it was not till 3.50 a.m. that I struck anything but Morse, and then, after careful tuning, W.G.Y. came through beautiful and clear, but of course, with a lot of fading occasionally. At times I almost think it would work a loud-speaker. At any rate,

I was far in front of anything that the B.B.C. have S.B. yet. At 5.9 W.G.Y. closed down. Now I think it is a fine achievement for two valves. I mean to keep to it and see if I can do still better. So far reaction in any position is out of the question. To bring either coil together causes loud noises; I have to keep all three as far apart as a three coil holder will allow. I might mention that I used a "Thorpe" K.1 valve and Xtraudion. My components are all cheap and of no well-known make, and all on wood without any proper insulation.

I remain yours 'etc.,

D.F.M.

Handsworth,

Birmingham.

To the Editor of MODERN WIRELESS.

SIR,—You will perhaps be interested to know that I have tried out Mr. Percy Harris's 3 valve circuit (described in the February issue of MODERN WIRELESS) in which he makes a bid for stability in H.F.

I find the circuit splendid—even using 3 Wecovalves, 1 H.F., 1 Detector and 1 L.F. After one or two attempts to use a Wecovalve as H.F. I had almost given up trying further with Wecos for H.F., as they needed so much grid bias to hold them on the panel, so to speak. I tried Mr. Harris's circuit and even introduced reaction from the Detector Valve and got very fine results here, quite easily the result of 4 valves and reaction. I don't think I am exaggerating by saying this.

Wishing your excellent paper every success, as it surely deserves it. Yours faithfully,

E. WHITFIELD.

Coniston, Lancs.

Special Aids for the Constructor

- How to Make Your Own Broadcast Receiver ... 1/6
- John Scott-Taggart, F.Inst.P., A.M.I.E.E.
- The Construction of Wireless Receiving Apparatus ... 1/6
- P. D. Tyers.
- How to Make a "Unit" Wireless Receiver ... 2/6
- E. Redpath.
- Twelve Tested Wireless Sets ... 2/6
- Percy W. Harris.
- Home-built Wireless Components The Construction of Crystal Receivers ... 1/6
- Alan L. M. Douglas.
- Wireless Sets for Home Constructors ... 2/6
- E. Redpath.
- Radio Press Envelope No. 1. How to Make an S.T.100 Receiver ... 1/6
- John Scott-Taggart, F.Inst.P., A.M.I.E.E.
- Radio Press Envelope, No. 2. How to Make a 4-valve Family Receiver ... 2/6
- Percy W. Harris.

From all Booksellers, or sent on receipt of remittance, plus post 3d. (3d. on R.P. Envelopes) extra, direct.

“SONOLA” REGD.
CONSTRUCTIONAL
WIRELESS
RECEIVING SETS.

These Constructional Sets are in every case sent out with ready drilled panels, assembled Condensers and Transformers ready wound, together with Wiring Diagram. For full particulars of our complete range of Constructional Sets, including Crystal and Amplifying Panels, see Catalogue M/105, free on request.

2-VALVE PANEL.
 Complete Set of Parts,
£5 7 0.

MARCONI ROYALTIES 25/- extra.

3-VALVE PANEL
 (as illustrated).
 Complete Set of Parts,
£6 15 0.

MARCONI ROYALTIES, 37/6 extra.

4-VALVE PANEL.
 Complete Set of Parts,
£9 0 0.

MARCONI ROYALTIES, 50/- extra.

RADIO WIRES.

Silk, Cotton and Enamelled Wires, Aerial and Leading in Wires, Telephone Receiver and Loud-Speaker Cords, etc. Competitive Prices. Prompt Deliveries. Send your Enquiries.

TERMINALS & STAMPINGS.



See Catalogue M/105 for full particulars, prices and illustrations of our wide range. Keen Prices. Prompt Deliveries.

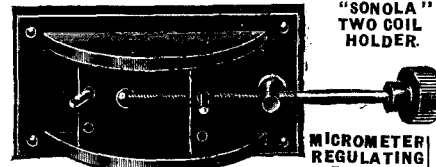

“SONOLA” TWO COIL HOLDER.

MICROMETER REGULATING
 P. Patent.

Enables the finest possible tuning and adds considerably to the efficiency and selectivity of the Receiving Set. **PRICE 10/- EACH.**

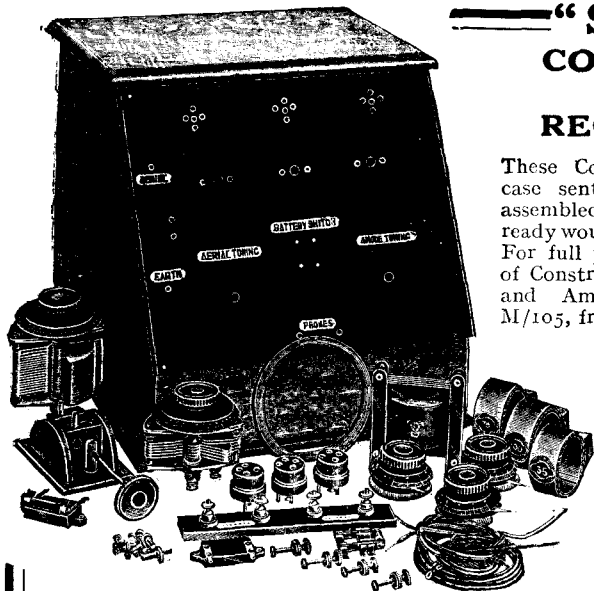

WHAT USERS SAY!

Mr. J. M., Junr., Cross Lane, Manchester. March 17, 1924.

May I congratulate you on your new 2-valve cabinet set recently supplied to me.

In finish, the set is as near perfection as it is possible to make it. Its achievements up to the time of writing are as follows:

Using 2 B.T.H. dull emitter valves, and operating the set at Bramhall, near Manchester, with quite a small aerial, I was able to receive all the B.B.C. stations except Bournemouth while 2ZY was working, Bournemouth coming in when Manchester was off.

G.K.U. (Devries) 2,100 metres (continuous wave) was heard working with liners at sea, some of the liners' replies being heard. Lastly, I heard the International Time Signal from P.O.Z. (Nauen, Germany) at 12 midnight, all of which goes to prove that the set works as well as its appearance is neat.

Mr. J. B., Palace Square, Manchester. February 14, 1924.

You may be interested to know that the 2-valve constructional set, supplied by you a few weeks ago, has been in daily use and given the utmost satisfaction.

I can, without the slightest difficulty, receive quite clearly from all the Broadcasting Stations, including Paris, and so recent as last night I received the concert direct from London at a strength almost equal to that of Manchester, which I suggest is unique—this, of course, was whilst Manchester was Broadcasting. Originals can be seen at Head Office.

Fully illustrated Radio Catalogue, No. M/105, post free on request. Enclose Business Card or Memo for Special Trade Terms and Discounts.

Stocked by all high-class Radio & Electrical Dealers. Refuse Substitutes. Write direct if unobtainable.



Address all communications to Head Office, and Works—PENDLETON, MANCHESTER. Glasgow Depot—95, PITT STREET.

MAGNIPLEX AERIAL MEANS 40 PER CENT. INCREASED AERIAL EFFICIENCY

The Range, Strength and Clearness of Signals is increased up to 40 per cent. by installing a MAGNIPLEX AERIAL.

This applies to both Valve and Crystal Sets. Made of Special Woven Wire Gauze of High Tensile Strength and Conductivity.

Patent Applied for.

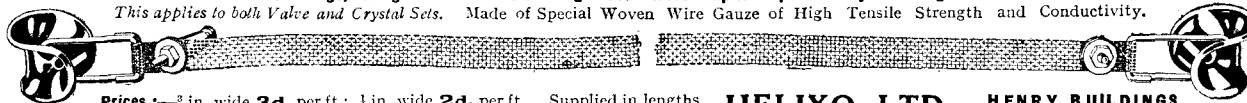

Prices:— $\frac{3}{4}$ in. wide 3d. per ft.; $\frac{1}{2}$ in. wide 2d. per ft. Supplied in lengths of 50, 75 and 100 feet, including fittings, viz:—End Terminal for Down Lead and Insulators ready for erecting. For lengths under 50 ft. fittings charged 1s. 3d. extra. Postage & packing 1s. extra.

HELIXO LTD., HENRY BUILDINGS, GRESSE STREET, RATHBONE PLACE, LONDON, W.1. Phone: Museum 6039

THE LONDON TELEGRAPH TRAINING COLLEGE Ltd.

Morse House, Earl's Court, S.W.

Telephone: Western 2696. Established 28 Years. OFFICIALLY RECOGNISED BY THE WAR OFFICE, THE ROYAL AIR FORCE AND POST OFFICE AUTHORITIES.

CABLE AND WIRELESS TELEGRAPHY.

PARENTS DESIROUS of placing their sons in either of the above Services and of affording them the best training facilities should apply for particulars of Courses and the methods of instruction which place this Institution in the first rank. Cable Telegraphy offers at the present time excellent prospects to youths from 16 years of age and upwards, and the College has exclusive facilities for obtaining posts for qualified students in the leading Cable Companies at commencing salaries of from £200 to £300 per annum, with yearly increments of £12 to £25, and with ultimate possibilities of obtaining

positions as Supervisors, Assistant Superintendents, Managers, etc.

In the Wireless Telegraph Service the commencing salary at the present time is about £90 per annum, plus free maintenance on board Ship, which makes the total remuneration approximately £150 per annum, and Operators when qualified by holding the Postmaster-General's Certificate of Proficiency are nominated by the College for appointments, of which there are a considerable number available at the present time. Positions are also obtainable in the Royal Air Force.

No Correspondence Classes or Branches. Apply for Prospectus to THE SECRETARY (Dept. M.W.), 262, Earl's Court Road, Earl's Court, London, S.W.5.

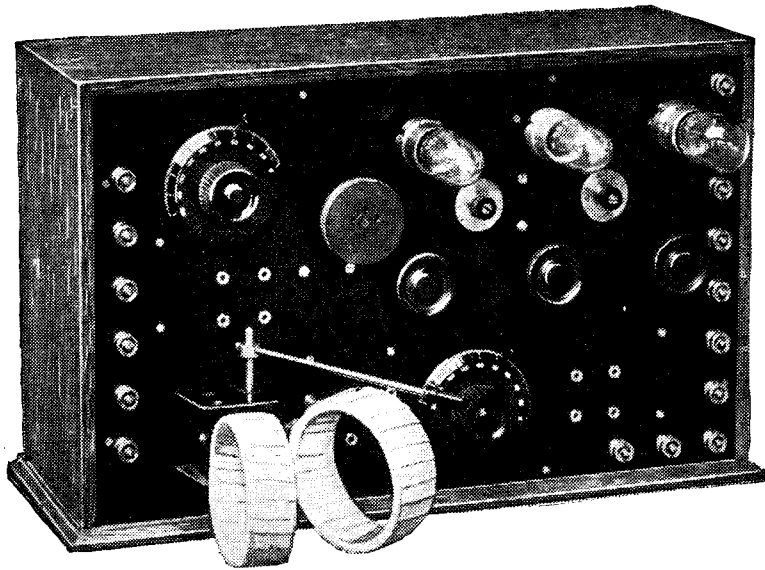

PRICES :

Complete Set of Parts to build up this Receiver, including drilled, tapped and engraved panel, two Max-Amp Transformers, two best quality all-metal Variable Condensers, each fitted with vernier control, Microstat filament resistances to enable dull or bright emitter valves being used, two variable resistances, a two-coil holder, all necessary valve holders, plug sockets, terminals, etc. **£6 10 6**
 Marconi Royalty **1 17 6** extra
Polished Cabinet with Sliding Door 0 15 6
Finished Instrument, aerial tested, complete in cabinet as above 10 10 0
 Marconi Royalty **1 17 6** extra
 Excluding Valves, Coils and H.F. Transformer in each case.
Panel only, Drilled, Tapped and Engraved 1 4 6

PETO-SCOTT, Ltd., 64, HIGH HOLBORN, W.C.1.

Head Office:
 W.C.1.

Branches: **99, High Holborn, W.C.1.**
230, Wood St., Walthamstow. Cardiff :
94, Queen Street. Liverpool : 4, Man-
chester St. Plymouth: near Derry's Clock
Gilbert A.D. 783

Three-Valve Dual

—the wonderful Set evolved by
 Mr. SCOTT-TAGGART, and described
 in last month's issue of "Modern Wireless."

Full-size Blue prints for Wiring and Drilling supplied free of charge.

ALL those applying for our 48-page Catalogue (post free, 3d.) are entitled to obtain entirely without charge a full-size blue print of the panel lay-out and wiring diagram of this splendid Set. All that the Home Constructor has to do is to cut his panel to size, paste the drilling diagram to it and drill exactly where indicated. Every hole will be absolutely accurate and the whole operation will not have taken more than a few minutes. And this method is a positive guarantee that components will be accurately spaced out and in their proper positions to avoid all risks of howling, interaction and distortion. In all reflex receivers this is most essential.

How to make a "unit" Wireless Receiver

R.P. Series, No. 7.



A **SPLENDID** constructional Book actually dealing with every possible item in the home-building of this unique 4-unit Receiving Set, consisting of H.F. Amplifier, Crystal Detector and Note Magnifier. It is capable of picking up Broadcasting 200 or more miles away and working a Loud-Speaker at 50 miles. Get a copy TO-DAY and build the Set—you will be more than satisfied with the results.

Published by
Radio Press, Ltd.
 Devereux Court,
 Strand, W.C.2

2/6

or 2/8, post free, direct.

Your Aerial!

TAKE a little trouble with your Aerial and you will be amply repaid by the vastly superior results you will get. Besides, a poorly erected Aerial is often a menace—it might collapse and cause serious damage. Better put up a good one while you are on the job. Get a copy of this Book and read how easily a good one may be erected.

Radio Press, Ltd.,
Devereux Ct., Strand, W.C.2.

From all
 Booksellers
 and News-
 agents, or
 1/2 Post
 Free.

Radio Press
 Wireless
 Library
 No. 4.



How to erect your Wireless Aerial

By B. Mitchell, A.M.I.E.E

USEFUL ADVICE!

Unless a Leak of the proper resistance is placed across the grid condenser the valve will either choke or the effect of the condenser be destroyed. The value depends on both the characteristics of the valve and the circuit, and can only be obtained through using the "BRETWOOD," the only accurate variable grid leak of watch like precision and scientific design.

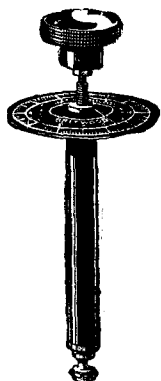

(Pat. P.O.)

Liberal Trade Discounts

PRICE 3/-

The only Grid Leak with which it is possible to supply a reliable Chart giving 25 different readings covering from 100,000 ohms to 10 megohms. This Chart is supplied for use with the "Bretwood" Grid Leak only, at a cost of 1/3. Send yours to be calibrated and Chart supplied.

IMPOSSIBLE to short circuit valve when using the BRETWOOD Valve Holder which acts as its own jig and valve fits flush to panel. Valve legs are held yielding by ball bearing spring device, thus always assuring perfect contact. One screw fixing only. PRICE 1/9.

RADIO IMPROVEMENTS LTD.

95, Great Portland Street, W. 1.



FOR SECURING YOUR AERIALS

And a thousand purposes where great strength and strain is needed. FLEXIBLE STEEL WIRE ROPE, Aeroplane Cable made to Govt. specification to specified breaking strains. PRICES BELOW COST. Orders of 10/- and over carriage paid, otherwise, please add 1/- for postage.

No.	Dia.	Strain. 100 ft.	No.	Dia.	Strain. 100 ft.	No.	Dia.	Strain. 100 ft.
0	1/16	5 cwt.	4	3/8	45 cwt.	12	1/2	70 cwt.
1	1/8	20 cwt.	5	1/4	70 cwt.	14	5/8	120 cwt.
2	3/16	25 cwt.	6	9/32	80 cwt.	15	3/4	140 cwt.
3	1/4	25 cwt.	7	1/2	110 cwt.	16	7/8	160 cwt.
4	5/16	25 cwt.	8	5/8	120 cwt.	17	1	180 cwt.
5	3/8	25 cwt.	9	13/32	140 cwt.	18	1 1/8	220 cwt.

Strainers for use with above, right and left hand threads. 9d. each of 8/6 per doz.

SMITH & ELLIS, Ltd. (Dept. 85), 11, Little Britain, E.C.1. Tel. City 8994.

Manufacture of Broadcasting Apparatus.

USE OF PATENTS

THE pioneer work of the Marconi Company in connection with wireless telegraphy and telephony is well known, and as the result of many years of research work and considerable expenditure, the Company controls numerous patents relating to the manufacture or use of wireless telegraph and telephone apparatus.

The Company is prepared to grant a licence for the use of its patents in connection with the manufacture of broadcasting apparatus to any member of the British Broadcasting Company, Limited.

A large number of firms (including the principal manufacturers) are already so licensed and pay royalty for the use of these patents, and all apparatus manufactured under licence is so marked.

Any persons or firms manufacturing or offering for sale valve apparatus embodying patents controlled by Marconi's Wireless Telegraph Company, Ltd., without its permission render themselves liable to legal proceedings for infringement.

Whilst hoping that it will not be forced to take legal proceedings the Marconi Company wishes to give notice of its intention to protect its own interests and those of its licensees, and in cases of infringement the Company will be reluctantly compelled to take such steps as may be necessary to defend its patent rights.

Marconi's Wireless Telegraph Co., Ltd.,
Marconi House, Strand, London, W.C.2.

Charge your ACCUMULATORS at HOME for a FEW PENCE by the **LONGTON IMPROVED ELECTROLYTIC CHARGER** (FOR USE ON A.C. SUPPLY).

NOTHING TO ADJUST—SILENT—NO MOVING PARTS
Price £5 15 0
SENT ON TRIAL FOR 1 WEEK and money returned if not satisfied.
H. LONGTON,
Manufacturing Electrical Engineer,
43, Johnson St., Westminster, S.W.

FORMO SERVICE

THE FORMO-DENSOR!!!

A PERFECT INSTRUMENT, SCIENTIFICALLY AND MECHANICALLY. MAIN VANES AND VERNIER OPERATED BY SINGLE KNOB.

The FORMO-DENSOR is British-made and constructed on entirely new principles, and, at the price offered, is unexampled value, and is the greatest advance yet made in condenser design.

Do not buy Condensers till you have seen the FORMO-DENSOR. The Famous FORMO COMPONENTS are original in design and are not approached for Price or Performance. We are at the BRITISH EMPIRE EXHIBITION, PALACE OF ENGINEERING, AV. 11, BAY 8.

THE FORMO COMPANY

(ARTHUR PREEN AND CO., LTD.)

Offices & Works: 22, Cricklewood Lane, N W. 2. 'Phone, Hamp. 1787

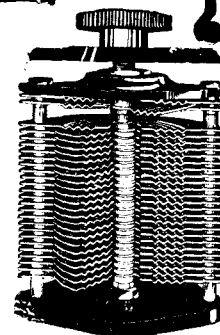
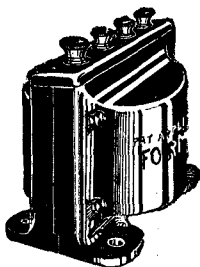

Complete with Knob, Dial and Vernier.
.001, 10/6
.0305, 9/6
.0303, 8/6

There is no other Condenser so perfect, and none at such a low price.

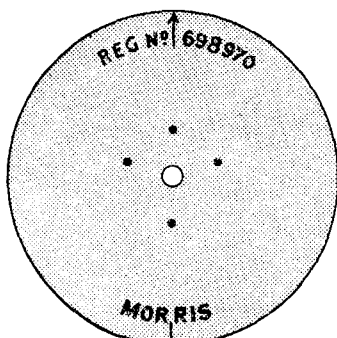

THE "MORRIS" (ALL STEEL) VALVE TEMPLATE

Marks out the position for your valve legs.

No Centre Punch required, no instruments.

Post 10 1/2 d. Free.

Note the Address:

NICHOL & CO., 46, Lancaster Ave., Fennel St., Manchester

S.A.C. DETECTOR

FROM 3/-

OMNI PANELS

S.T. 100—S.T. 100 STAR

COMPLETE COMPONENTS; DRAWINGS AND INSTRUCTIONS From £7-10-0

INCLUDING VALVES, H.T., Etc. (Colonial Buyers Please Note)

Ask for New List

or send P.O. 1/- for List and New Electrical Game. Credited against first purchase.

"S. A. CUTTERS," 15, Red Lion Sq. CHANCERY 3342. LONDON, W. C. 1

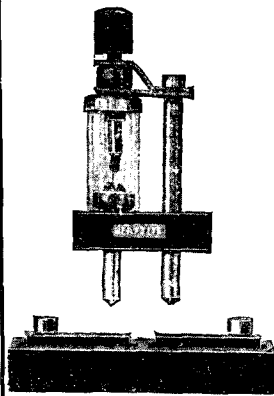



Complete the pleasures of Radio with *Wireless Weekly*

The man who owns a Receiving Set and treats it merely as a means of obtaining entertainment at little cost from the ether is missing one of the greatest joys of Broadcasting. For only those who really understand the principles—who can explain to their friends how Broadcasting is effected—and who, maybe, can build Instruments which will remain a visible sign of the interest they have taken in the newest and greatest of the Sciences—only these feel the real thrill of Radio.

It is to such a man that "Wireless Weekly" makes its greatest appeal. Educational without

being over-scientific—instructive without being boring, it undoubtedly wields the greatest influence among the young go-ahead experimenters of to-day.

Although in point of cost it is not the cheapest of weekly Radio Magazines, yet in comparison with the number of its pages, the lavishness of its illustrations and the dependability of its information, it certainly offers remarkable value for money. Why not purchase a copy of the current issue at your Newsagent's and form your own opinion—we will be well content to abide by your decision.

Wireless Weekly

As good as

Modern Wireless

6^d

WIRELESS WEEKLY is sold by all
Newsagents and published by Radio
Press, Ltd., Devereux Court, Strand,
W.C.2.

Gilbert Ad. 785.

THE KAYNITE PATENT RADIO COIL WINDING MACHINE

PATENT No. 189376
OF 1923.

AN OLD FRIEND
UNDER A NEW
NAME.

Every Experimenter
Recommends it!!

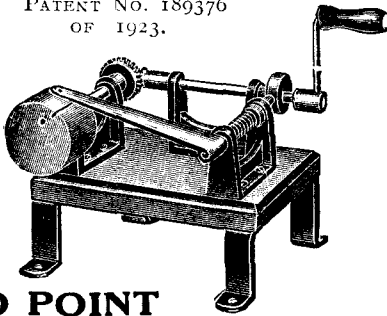

IT IS
RUDE TO POINT

but please excuse this time, as we feel it is our duty to point out that you can save pounds by winding your own sine wave lattice radio coils on the celebrated Kaynite Radio Coil Winding Machines. Model illustrated is Type A Machine, costing but 21s., and we can also supply the B Type Machine, fitted with automatic indicator, at 25s.

WRITE FOR DESCRIPTIVE PAMPHLET. A POSTCARD WILL DO.

If you cannot obtain locally send orders direct to the Sole Concessionaires,

A. W. KNIGHT LTD.

167, RYE LANE, PECKHAM, LONDON, S.E.15.

Telephone: - - - - - New Cross 2427.

EXPORT ENQUIRIES SPECIALLY SOLICITED.

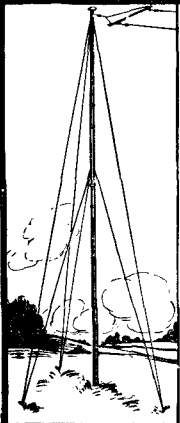

'TURRET' Columbian Pine Masts

700 IN USE.

Designed by Naval Experts.

REDUCED PRICES

27 ft. Turret Two Complete	37 6
28 ft. Turret Super Mast	53 6
36 ft. in 3 sections	71 6
42 ft. Telescopic Mast	78 6
45 ft. Super Telescopic	84 6
55 ft. Doubly Telescopic	£5 19 6
58 ft. Super Mast	£6 9 6
Turret Poles, 13ft.	5 9
16 ft. 2 1/2 in. base	7 9
28 ft. 2 pairs clamps	17 9
42 ft. 4 pairs clamps	29 9

Send for List.

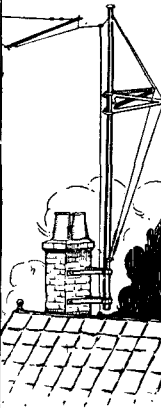

SIMPSON & BLYTHE, 8-9, Sherwood St., Piccadilly, W.1

YES, WE MAIL CABINETS!

And you receive them by return. Solid Mahogany and Hand Finished.

OMNI, 25/-; 3-VALVE DUAL, 25/-; S.T. PORTABLE, 32/6; W2 & W3, 16 by 9 Panel, 17/6; ST 100, enclosed, 27/6; ST 100, standard, 15/-; 4-Valve FAMILY and Panel, 18/6; W1, 12 by 8 Panel, 16/-; ALL CONCERT and Panel, 18/-; ST 100 W Type, 16/-.

All Types of Cabinets kept in Stock. Special Cabinets at 48 hours. Carriage and Packing Free.

WRIGHT & PALMER, Cabinet Makers, 335, Katherine Rd., Forest Gate, E. 7. Trade enquiries invited. Phone: East Ham 1151.

Sparta LOUD SPEAKER

—when tone is the first consideration

the "Sparta" is invariably first choice. Its most noteworthy feature is a remarkably rich fulness of tone. This is largely accounted for by the lengthy research expended upon each component, for the "Sparta" is the Speaker of combined excellence—the co-ordination into one instrument of all the worth while features in Loud Speaker construction. Why not visit a demonstration to-day and judge its merits for yourself?

- Type "A" 120 ohms .. £4 : 15 : 0
- Type "H.A." 2,000 ohms £4 : 15 : 0
- Type "H.H.A." 4,000 ohms £4 : 15 : 0
- Type "B" 120 ohms. The first Loud Speaker to provide for additional control through a 6-position tone selector .. £5 : 15 : 0

Write to-day for List No. 315a.

FULLER'S UNITED ELECTRIC WORKS, Ltd.
Woodland Works, Chadwell Heath, Essex.

Telephone: Ilford 1200 (6 lines). Telegrams: "Fuller, Chadwell Heath."

London Depot: 53, High St. W.C.2.

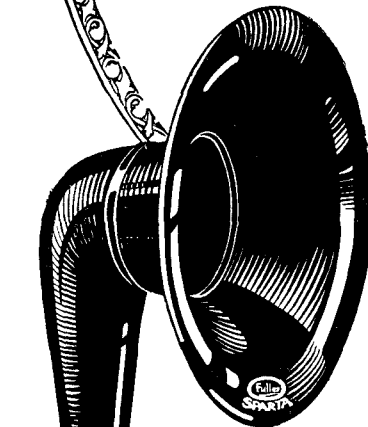

Demonstrations of the "Sparta" Loud Speaker are given during broadcasting hours at Gamage's, Harrods, Selfridges, The Service Trading Co., 289-292, High Holborn, City Accumulator Co., Ltd., 70, Mark Lane, E.C. 3, Salmon, 33, Grafton Street, Tottenham Court Road, Peto-Scott, Ltd., 64 & 90, High Holborn, Piggott Bros., Bishopsgate, E.C. 2, etc., and at our own depots

Perfect reproduction of the excellent dance music regularly broadcast demands a perfect Loud Speaker—the "SPARTA."



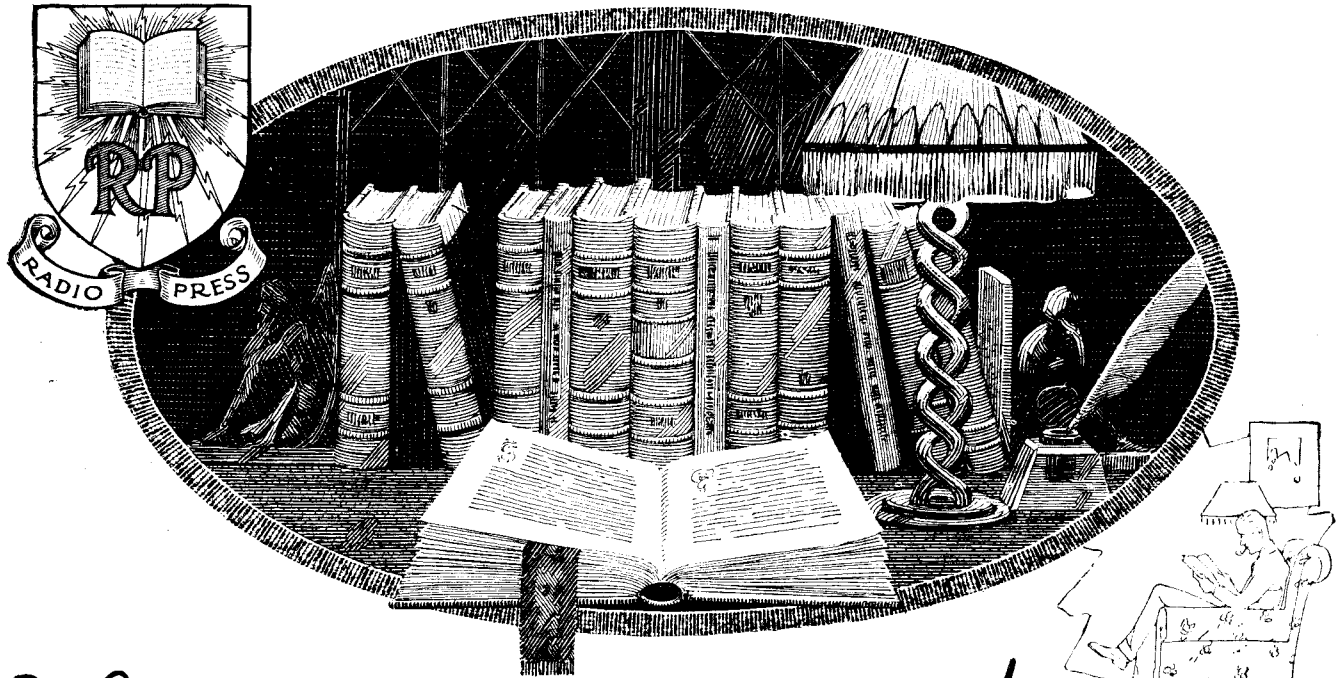

A Reference Library for 2/6.

WITH the large number of really good Books on Wireless published by Radio Press Ltd., it is a little difficult for an enthusiast to pick out the most useful of them. The Book **500 Wireless Questions Answered**, however, by its immense sales, has already proved itself as being the most popular — two editions having been exhausted since last November.

Its wide scope—coupled to the fact that it deals only with live and useful information—is rendering it indispensable to every

Broadcast listener and experimenter.

Certainly, previous to its publication it would not have been possible to have obtained one half of the information contained within its two covers under an expenditure of several pounds. And even then the information would not have been given in such a concise and compact form, well indexed, and available at a moment's notice.

Such a Book as this will save its cost many times over—it can certainly be described as a *Reference Library for half-a-crown*.

Contents

Aerials.
 Amplifiers.
 Crystals and Crystal Sets.
 Earths.
 Frame Aerials.
 Grid Leaks and Condensers.
 Interference.
 Loud Speakers.
 Morse.
 Primary Batteries.
 Ranges.
 Reaction.
 Secondary Batteries.
 Sounds and Signals.
 Telephone Receivers.
 Tuning Coils.
 Tuning Condensers.
 Valves.
 Wavelengths.
 Waves.
 Wire.
 Miscellaneous problems.

RADIO PRESS LTD., Devereux Court, Strand, W.C. 2.

Post free
2/8

2/6

500 Wireless Questions Answered

By G.P. Kendall & E Redpath. Post free 2/8

THE "ROYAL" TRANSFORMER

LOW FREQUENCY INTERVALVE SUPER
"STANDS ALONE FOR PURE TONE"

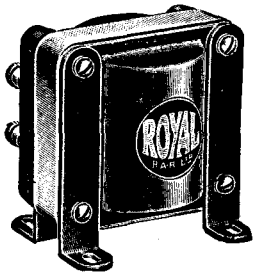

EVERY FEATURE of the design of this transformer sets it apart as a superior product. High-grade silicon alloy steel is used for the core; the windings are VACUUM IMPREGNATED; a metallic shield covers the general assembly, preventing any effect from near-by wiring. Convenience as well as safety is served in this transformer by the wide separation of the terminal blocks, which are made of CETEC, a high dielectric moulded composition developed in our own laboratories. This separation not only eliminates any possibility of leakage between terminals, but also permits greater ease in making connections. The transformer is packed in corrugated carton.

LIST PRICE £1-0-0 each.

2 3/4 in. high x 2 3/4 in. wide x 1 1/2 in. deep over all. Nominal ratio 4 to 1.

The following is one of many unsolicited testimonials we have received:
"Graylands," Somerville Gardens, Leigh-on-Sea.
Dear Sir,—I think you would be interested in the results of a trial from 'Royal' transformers on a S.T.100 circuit. Aberdeen, 500 miles distant, was picked up, also all B.B.C. stations, and on loud speaker Cardiff was quite loud. This place is 2 1/2 miles distant. Excellent, don't you think? If you have any other wireless components I should be glad to hear of them, as your Transformers are really most excellent.
Yours faithfully, W. F. PRESTON-COBB.

This wonderful transformer is recommended by Mr. J. Scott-Taggart, F.I.P., A.M.I.E.E., for use in several of his renowned circuits.

THE 'ROYAL' SUPER TRANSFORMER IS MADE IN ONE NOMINAL RATIO ONLY, I.e., 4:1. SIMILAR 'ROYAL' TRANSFORMERS CAN BE USED FOR FIRST AND SECOND STAGE LOW-FREQUENCY AMPLIFICATION, WITH ABSOLUTELY DISTORTIONLESS CRYSTAL CLEAR TONE QUALITY. WITH WHAT OTHER TRANSFORMER CAN YOU DO THIS?

Write for early particulars of our wonderful new D.R.6 set, embodying our new "Solion" non-oscillating valve—the valve with the ten times radius. Agencies open in few districts:

R. A. ROTHERMEL, Ltd.
24 & 26, Maddox Street, Regent Street, London, W.1.



I have had
20 YEARS'
EXPERIENCE

WE TEACH
BY POST.

Most Moderate
Charges
Payable Monthly.

Engineering Dictionary
PART ONE FREE.
To extend the name of the Bennett College we are publishing an Illustrated Encyclopaedic Dictionary of Engineering, Civil, Motor, Elect., Mech. The proper price is 25/-; it is in 24 monthly parts of 16 pages each part. You may have Part 1 free, and if you are satisfied send only 6/- and you will receive all the other 23 parts. This offer only applies to the first 1,000 applicants. Send for Part 1 to-day; you are under no obligation.

Have You Any Ambition?

To Learn a Trade or Profession, or go higher in your present vocation. Have you a son? Does he, or do you, wish to pass any qualifying Exams? Remember every man is the Architect of his own fortune, and I can show you how to study in your spare time (by post) and thus reach the highest positions. As my advice is free, write to me and let me help you as I have helped thousands of others.

We specialise in all Exams.

J. W. Bennett

- | | | |
|------------------------------|------------------------|--------------------------|
| COMMERCIAL | TECHNICAL | Foundry Work |
| Accountancy | Architectural | Internal Comb. Engines |
| Advertising and Salesmanship | Drawing | Marine Engines |
| Auditing | Building | Engineering |
| Banking | Construction | Mathematics |
| Book-keeping | Clerk of Works' duties | Matriculation |
| Commercial | | Metallurgy |
| Arithmetic | Aviation | Mining |
| Commercial Law | Boiler Engineering | Mine Surveying |
| Company Law | ing | Motor Engineering |
| Costing | Boiler Making | Naval Architecture |
| Economics | Chemistry | Pattern Making |
| English and French | Civil Engineering | Sanitation |
| Executorship Law | Concrete and Steel | Shipbuilding |
| Modern Business Methods | Draughtsmanship | Structural Engineering |
| Secretarship | Electricity | Surveying and Levelling |
| Workshop | Engineering | Telegraphy and Telephony |
| Organisation | | Wireless Telegraphy |

WRITE FOR FREE BOOKLET

to The BENNETT COLLEGE, Dept. 134, SHEFFIELD, naming the subject you are interested in. Please state your age. Courses specially combined to meet all requirements. Why Stay in the Rut?



EVER-READY

BRITISH MADE

Best British Batteries

THE Ever Ready series embrace all types of Dry Cells, Batteries and Accumulators for every Wireless purpose, and the range is continually supplemented to conform with up-to-date requirements.

We are exhibiting at
The **BRITISH EMPIRE EXHIBITION**

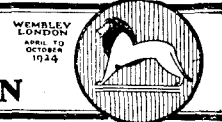

Palace of Engineering,
Avenue 14, Bays 7 - 8



A Special section of our display is being devoted to illustrating the high quality raw materials used in the manufacture and production of EVER READY Wireless Batteries. Ask for our booklet giving hints on the care and use of Dry Batteries, and obtain the maximum efficiency from your apparatus, or same will be sent with standard sizes and voltages on application to

Service "BY" Dept.

The EVER READY CO. (Great Britain) Ltd.
HERCULES PLACE, HOLLOWAY, LONDON, N.7.

THE MIC-MET SUPER CRYSTAL DETECTOR

(Prov. Patent 22153). This instrument is micrometric in principle and ensures a perfectly adjusted and rigid contact between crystal and contactor. By a combination of movements between the three knobs, any portion of the exposed part of the crystal may be contacted. For S.T.100 and other circuits employing crystal rectification, the most efficient detector to use is the MIC-MET. Can be obtained from your local wireless dealer or direct from the manufacturers on receipt of 6s. P.O. Trade enquiries solicited.

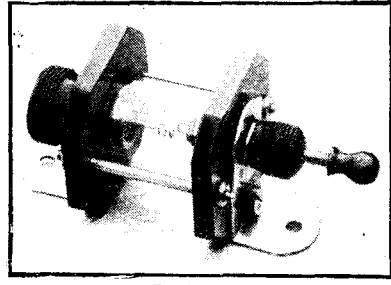

British Make
C. & J. ARRIGONI, COMPTON PASSAGE, CLERKENWELL, LONDON, E.C.1.

When making up your set use

"SPADPIN"

(Patent applied for)

TERMINALS

THEY DO DOUBLE DUTY

(See Illustration).

and are Beautifully Finished.

PRICES PER DOZEN

1/2 inch diameter: lacquered, 3/3; nickelled, 5/3.
3/8 inch diameter: 4/9; 6/9.

(Prices include Nut and Washer on every Terminal, and Postage)

READING RADIO INSTALLATIONS,
17, King's Road, Reading,

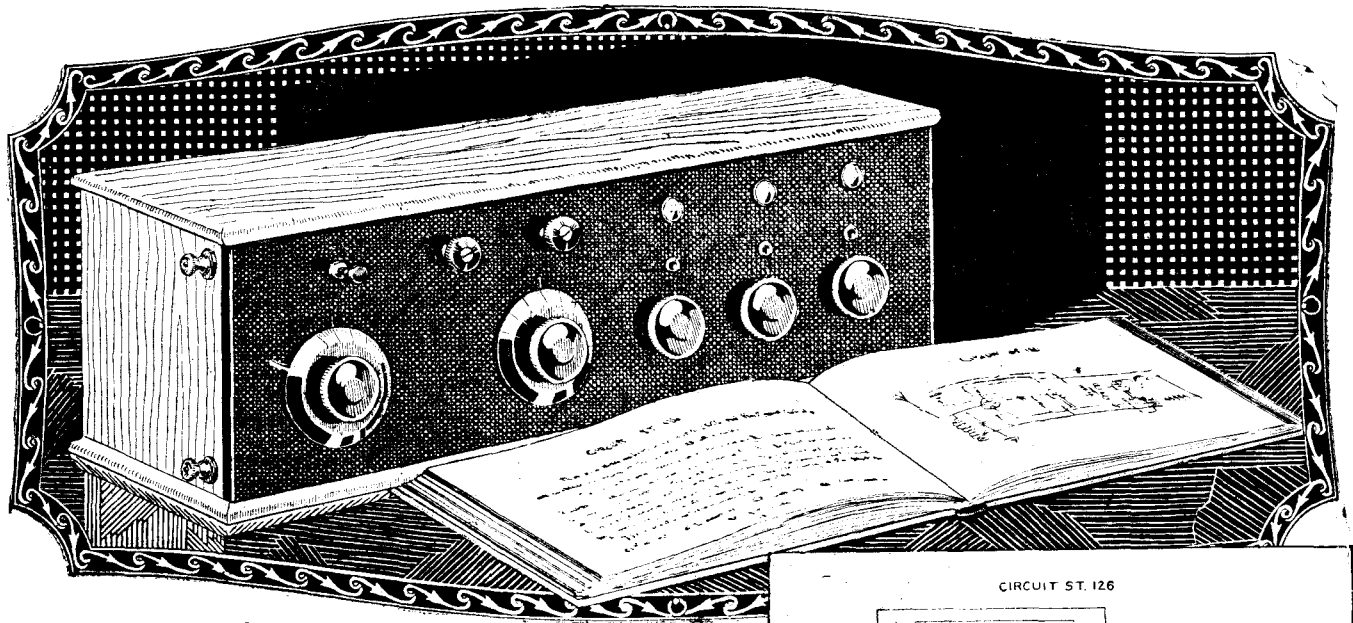

all the information
you need given clearly
and accurately.

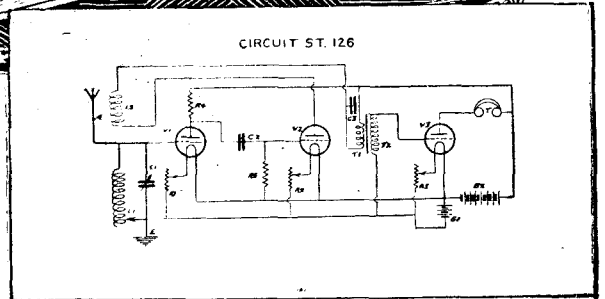

ALL the difference between success and failure in building a home-made Set lies in the correct values of the components and their arrangement.

Anyone who possesses a little wireless knowledge and who has built up a Set before will be able to pick up a copy of **More Practical Valve Circuits**, by John Scott-Taggart, F.Inst.P., and build any type of Set according to his own ideas and incorporating any of the scores of circuits described in it without further assistance.

These clear diagrams are so accurate and the descriptions given are so complete that to a man who already knows something about Wireless, the Book is almost as good as a huge constructional Book showing how

to build dozens of different types of Instruments.

For instance, opposite every Circuit is a full description of it—its advantages and disadvantages, how it should be used, the values of the fixed condensers and resistances, and so on. All this information is given because every Circuit is a practical one, and not a paper one. You can be confident that it will do all that is claimed for it.

This Book contains a very large number of circuits, including all the recent reflex circuits, together with such "super" Circuits as the Armstrong and the Flewelling. It is beautifully printed on good quality paper and bound in full cloth—a real reference Book, in fact, one you will find useful almost daily. Get a copy from your Bookseller to-day.

RADIO PRESS Ltd., Devereux Court, Strand, W.C.2.



More Practical Valve Circuits

By John Scott-Taggart, F.Inst.P.

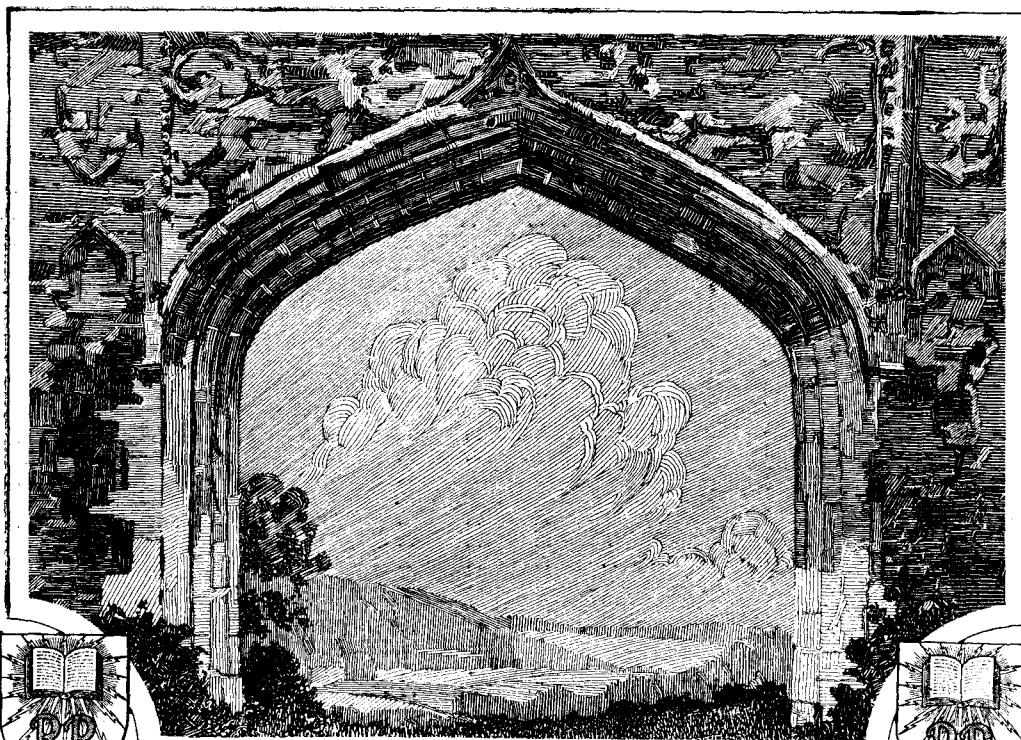

The Gateway to Knowledge.

The library of Radio Press Books is assuredly a very real gateway to knowledge.

within 20 miles from a B.B.C. Station) will probably select a Crystal Set from R.P. Book No. 3, while the more expert will want to select Receivers from R.P. Books No. 14 or No. 17. The new Series of Radio Press Envelopes are an endeavour to make the building of Sets the simplest possible operation—one involving no technical skill or knowledge. All these Radio Press Books are written by experts and their contents are accurate and reliable. You can purchase them at any Bookseller's, or we will post any of them direct (postage 2d. per Book extra).

If you are a beginner you will be able by its aid to appreciate something of the miracle of Radio—how its waves travel at the speed of light and penetrate even the depths of a coal mine. You will readily learn how the voice is "converted" into these wireless waves at the Broadcasting Station and picked up by your Aerial and "reconverted" by your Receiving Set in your own home. If, on the other hand, you are anxious to build a good Set, then you will find a wide choice of Instruments available in this Series of Books. The man making his first Set (if he lives

RADIO PRESS LTD.,
The largest wireless Publishers in the world,
Devereux Court, Strand, W.C.2.

	Price
1 Wireless for All	9d.
By JOHN SCOTT-TAGGART, F.Inst.P.	
2 Simplified Wireless	1/-
By JOHN SCOTT-TAGGART, F.Inst.P.	
3 How to Make Your Own Broadcast Receiver	1/6
By JOHN SCOTT-TAGGART, F.Inst.P.	
4 How to Erect Your Wireless Aerial 1/-	
By B. MITCHELL, A.M.I.E.E.	
5 The Construction of Wireless Receiving Apparatus	1/6
By P. D. TYERS.	
6 The Construction of Crystal Receivers 1/6	
By ALAN L. M. DOUGLAS.	
7 How to Make a "Unit" Wireless Receiver	2/6
By E. REDPATH.	
8 Pictorial Wireless Circuits	1/6
By OSWALD J. RANKIN.	
9 Wireless Valves Simply Explained 2/6	
By JOHN SCOTT-TAGGART, F.Inst.P.	
10 Practical Wireless Valve Circuits	2/6
By JOHN SCOTT-TAGGART, F.Inst.P.	
11 Radio Valves and How to Use Them 2/6	
By JOHN SCOTT-TAGGART, F.Inst.P.	
12 500 Wireless Questions Answered	2/6
By G. P. KENDALL & E. REDPATH.	
13 12 Tested Wireless Sets	2/6
By P. W. HARRIS.	
14 More Practical Valve Circuits	3/6
By JOHN SCOTT-TAGGART, F.Inst.P.	
15 Home-Built Wireless Components 2/6	
By JOHN SCOTT-TAGGART, F.Inst.P.	
16 Wireless Sets for Home Constructors	2/6
By E. REDPATH.	
17 Tuning Coils and How to Wind Them	1/6
By G. P. KENFALL, B.Sc.	
RADIO PRESS ENVELOPES.	
No. 1. How to Build an S.T.100 Receiver 1/6	
By JOHN SCOTT-TAGGART, F.Inst.P.	
No. 2. How to Build a 4-Valve Receiver 2/6	
By P. W. HARRIS.	
Nos. 3 and 4 to be issued shortly.	
SIMPLEX WIRING CHARTS.	
No. 1. For 2-Valve Set	1/-
No. 2. For 3-Valve Set	1/-
No. 3. For 4-Valve Set	1/-

If it is an R.P. Book — you can depend upon it

Index to Advertisers

	PAGE		PAGE		PAGE
Arrigoni, C. & J.	779	Finchett (C.A.)	746	Nichol (J. O.), & Co.	775
Autoveyors, Ltd.	749	Forno Co.	775	Peto-Scott Co.	739, 774
B. D. & Co.	769	Fuller's United Elec. Works, Ltd.	777	Pickett Bros.	764
Bell Laboratories	764	Gamage, A. W.	749	Power Equipment Co.	763
Bennett College	779	Gambrell Bros., Ltd.	768	Radio Communication Co., Ltd.	760
Bower Elec. Co., Ltd.	720	General Electric Co., Ltd.	715	Radio Improvements	775
Bowyer-Lowe Co.	720	General Radio Co.	753	Radio Instruments, Ltd.	Cover iv.
Brandes, Ltd.	716	Gent & Co.	750	Radio Mail Order Co.	766
British Battery Co., Ltd. (The)	750	Goswell Engineering Co.	747	Radians, Ltd.	739
British Thomson-Houston Co., Ltd.	610, 770	Graham, A., & Co.	750	Raymond (K.)	758, 759
Brown Brothers Ltd.	727	Gran-Goldman Service	723	Reading Radio Installations	779
Brown (S. G.), Ltd.	736	Helixo, Ltd.	773	Regent Fittings Co.	772
Burndept, Ltd.	767	H. T. C. Electrical Co.	720	Roberts (A.) & Co.	746
Burne-Jones, Ltd.	764	Humphrys, W. E. H.	746	Robinson, Lionel, & Co.	756
City Accumulator Co.	728	Hunt (A. H.), Ltd.	764	Rose Bros., Elec. Co.	748
Clarke (H.) & Co., (Manchester), Ltd.	754	Igranic Electric Co., Ltd.	731	Rothermel (R. A.), Ltd.	779
Constable & Co., Ltd.	746	International Radió Mfrs., Ltd.	723	"S. A. Cutters"	775
Cossor Valve Co.	740	Jackson Bros.	732	Silvertown Co.	771
Cunningham & Morrison	732	Knight (A. W.)	777	Simpson & Blythe	777
Curtis (Peter), Ltd.	763	Levy, S.	746	Smith & Ellis	775
Drummond Bros.	749	Lissen Co.	719	Sparks Radio Co.	766
Dubilier Condenser Co. (1921), Ltd.	744	London Telegraph Training College	773	Sterling Telephone Co., Ltd.	723
Economic Electric, Ltd.	748	Loughton (H.)	775	Tickle, L. B. & Co.	727
Edison Swan Electric Co. Ltd.	735	Marconi Wireless Telegraph Co., Ltd.	775	Ward & Goldstone, Ltd.	773
Electric Appliances, Ltd.	743	McMichael (L.), Ltd.	769	Watmel Wireless Co.	766
Ever Ready Co.	779	M. L. Magneto Syndicate	739	Woodhall Wireless Co.	727
Fallon Condenser Co.	768	Molbaek (H.)	764	Wright & Palmer	777
Fellows Magneto Co., Ltd.	744	Mullard Radio Valve Co., Ltd.	724, 769		

WALKERS' WIRELESS
Hold the largest variety of wireless apparatus in the North. Send for particulars, 31, Westgate Road, Newcastle-on-Tyne.

Bargains in Wireless Goods. Filament Resistances 1 6 each. Grid leaks 2 meg 10d. each, postage extra. Send stamp for list. **WILSON BROS.**, 31, Jepson Lane, Elland.

J. DYSON,
5 & 7, Godwin Street, Bradford. Complete Sets. All Accessories. Tele 6037 & 6038. Telegrams: "Equipment."

A. Franks, Ltd., 95-97, Deansgate, 44, Market Street, 73, Oxford Street, 12, Victoria Street, Manchester, and 90, Bradshawgate, Bolton.

WIRELESS PROFESSION. — Immediate vacancies for number of students from 14 years of age upwards; those just leaving school preferred. Appointments guaranteed when qualified: commencing salary £150 per annum plus all found, rising to £500 per annum, according to number of years' service. Prospectus free.—Wireless College, Langdowne, Bournemouth.

PRESTON.
All Wireless Supplies, Complete Sets Installed, Phones and Valves Repaired, and Accumulators Recharged.—**WILKINSON'S WIRELESS SERVICE**, 152, Church Street (Opposite Miller Arcade).

EBONITE PANELS. Any size cut. 1/4 in. thick 1d. 5q. in. Post and packing 6d. Panels drilled to your own paper pattern 9d. extra. **Wormald & Son**, Mangnall St., Bradford Rd., Manchester. Trade invited for cut or in sheets. Phone: Central 2868.

COUPON

Questions and Answers

In future this coupon must be accompanied with 2s. 6d. P.O.

"MODERN WIRELESS" May, 1924

USE THIS COUPON

in writing to advertisers in "Modern Wireless."

CUT HERE

In connection with your announcement in MODERN WIRELESS, please supply me with:

Enclosed please find remittance of..... (Leave blank if not an order)

If an open envelope is used in applying for catalogues a half-penny stamp will cover postage.

Name.....

Address.....

Date.....

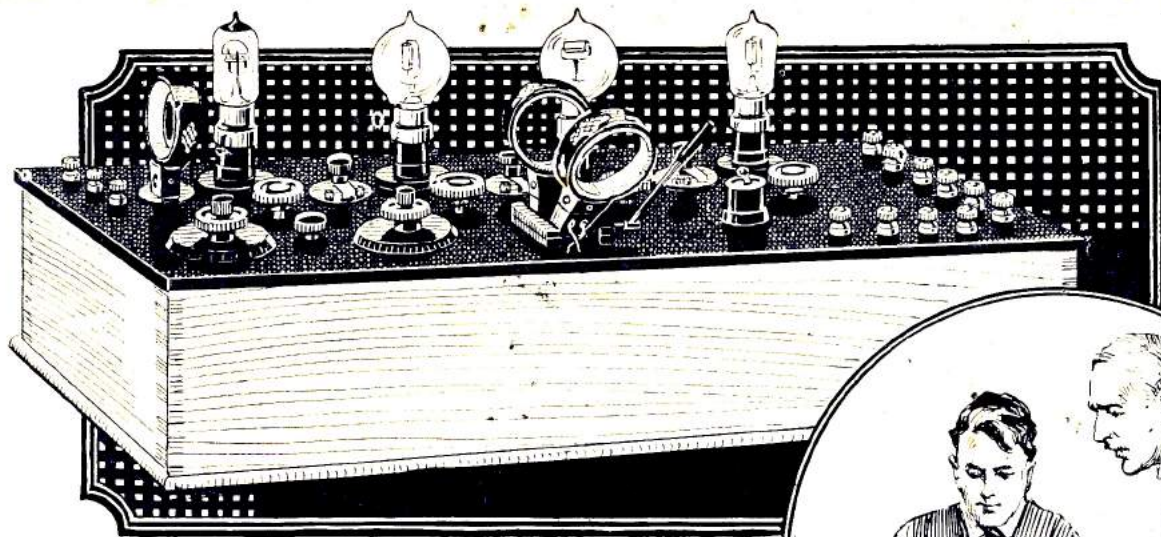

Even if you've never built a Set before . .

THERE are still plenty of Wireless enthusiasts who have still to build their first Valve Set. If they are afraid that they lack skill, here is a new method which will certainly smooth out difficulties.

Radio Press have issued two envelopes (No. 1 deals with the S.T. 100 Receiver). Each contains blue prints showing the lower side of the Panel and also the upper portion. All wiring connections are plainly indicated so that it is absolutely impossible for a wrong connection to be made.

Enclosed also is a portfolio with full instructions for assembly and operating. Nothing, in fact, has been omitted in an endeavour to make Set-building really simple.

Magazine articles are often, through exigencies of space, kept somewhat brief, and points which might prove difficult to the novice are overlooked.

In this envelope scheme, however, Radio Press are confident that, at last, a method has been devised whereby anyone can build up a first-class Receiver, professionally designed, at a most moderate cost.

The family four-valve Set shown above gives excellent Loud-Speaker volume, yet, by means of switches, any combination of Valves from one to four can be used at will.

Also on sale:

"How to Build an S.T. 100."

This envelope contains full instructions, together with set of blue prints and wiring diagrams for building up the S.T. 100. Remember this Set uses only 2 Valves, yet will receive every B.B.C. Station and work a Loud-Speaker with good volume at 50 miles. Price 1/6 (1/9 post free).

RADIO PRESS LTD., DEVEREUX COURT, STRAND, W.C.2.

2/6

Envelope No. 2

How to make A Family Four-Valve Receiver.

By Percy W. Harris. *Post free 2/9*

REALLY PORTABLE

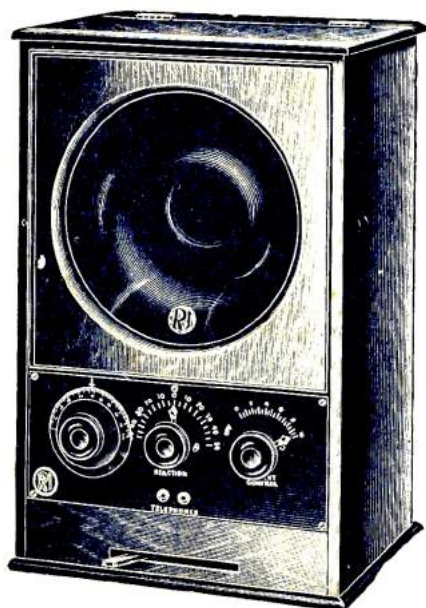

The Lyriette Receiver for B.B.C. Wavelengths. Complete portable Wireless Receiver, Standard Loud Speaker, D.E. Valves, Batteries, 2 Valve set. PRICE Complete **19 Gns.** B.B.C. Tax 15 -
3 Valve set. PRICE Complete **£25 18 0** B.B.C. Tax £1

You can carry it about anywhere, on the river, to the tennis club, in fact to any gathering, and it is always ready to put into operation at a moment's notice.

It is a complete receiver, the first of its kind, and will reproduce perfectly the Broadcasting concerts on its standard Loud-speaker. Its classic cabinet contains batteries, valves, all the accessories and

No accumulators are required.

Staple reception, Minimum adjustment, Instant Tuning.

Its case is strongly made, is easily adjustable and provides a perfect way of carrying this really portable set anywhere.

Unlike many of the firms who supply the public with wireless sets, R.I. never make sensational claims for their goods.

Write now for folder (M) describing this receiver.

RADIO INSTRUMENTS LTD.

Managing Director: J. JOSEPH, M.I.E.E.
Chief Designer: W. A. APPLETON, M.B.E., M.I.R.E. (late Admiralty Technical Research Officer).

Works, Offices and Showrooms:
12, Hyde St., New Oxford St., W.C.1.

Telephone: Regent 6214-6215-6216.

Telegrams: "Instradio London."

PROVINCIAL DEPOTS.

Manchester: 19, Hopwood Avenue.
Leeds: Trinity House, Commercial Street.
Birmingham: Britannia Works, Gr. Charles Street.
Glasgow: 47, Waterloo Street.
Dundee: Caird Hall, Dock Street.
Brussels: Trent Livres & Zwaab, 24, Rue de Malines.
Dublin: Brown Bros. (Ireland) Ltd., 18, William Street.
Belfast: Campbell, Gardner & Co., 44, Upper Arthur Street.

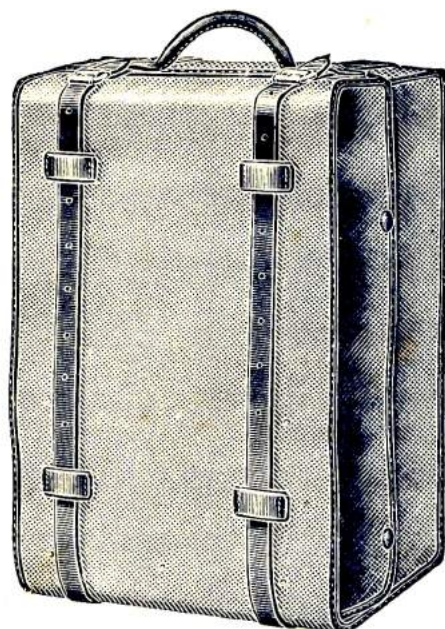

Case 2 guineas extra.

